



# USER MANUAL

## VA5 Pro A4404 – SAB Virtual Unit



Updated: June 27, 2024

# Content:

|   |           |
|---|-----------|
| <b>Introduction: basic instructions</b> ..... | <b>7</b>  |
| VA5 Pro.....                                  | 7         |
| A4404 – SAB (Signal Analyzer Box).....        | 7         |
| General warnings.....                         | 8         |
| Battery Charging.....                         | 8         |
| <b>Hardware</b> .....                         | <b>10</b> |
| Front View.....                               | 10        |
| Top View.....                                 | 10        |
| Rear View (with IR camera connected).....     | 10        |
| Connection to the computer.....               | 11        |
| <b>Input Channels</b> .....                   | <b>12</b> |
| IN1 Socket.....                               | 12        |
| IN2 Socket.....                               | 12        |
| IN3 Socket.....                               | 12        |
| IN4 Socket.....                               | 13        |
| TRIG Socket.....                              | 13        |
| Standard Cable Wiring.....                    | 13        |
| A4409 - BNC Box.....                          | 14        |
| <b>First steps with VA5 device</b> .....      | <b>15</b> |
| Switching on.....                             | 15        |
| Switching off.....                            | 15        |
| Sleep Mode.....                               | 15        |
| Auto Switch off.....                          | 15        |
| Emergency Switch off.....                     | 15        |
| Capacity Warning.....                         | 15        |
| <b>Main Screen</b> .....                      | <b>16</b> |
| Buttons.....                                  | 16        |
| Modules.....                                  | 17        |
| MENU button.....                              | 17        |
| Shortcuts.....                                | 17        |
| PC Connection Indication.....                 | 17        |
| Touch keyboard.....                           | 17        |
| Battery Lifetime.....                         | 18        |
| How to work with menus.....                   | 19        |
| How to work with lists.....                   | 22        |
| <b>MENU</b> .....                             | <b>23</b> |
| <b>MENU / SETTINGS</b> .....                  | <b>24</b> |
| Global Settings.....                          | 24        |
| Display.....                                  | 26        |
| Keyboard.....                                 | 27        |
| Language.....                                 | 27        |
| Appearance.....                               | 27        |
| Profiles.....                                 | 27        |
| User Notes List.....                          | 28        |
| Date/Time.....                                | 30        |
| Shortcuts.....                                | 30        |
| Signal Source.....                            | 30        |
| Trigger Settings.....                         | 30        |
| Runup.....                                    | 35        |
| Graph Properties.....                         | 35        |
| Sensors.....                                  | 36        |
| AC Sensors.....                               | 37        |
| DC Sensors.....                               | 40        |

|  |            |
|--|------------|
| ADASH  | VA5 Pro    |
| Tacho / External Sensors.....                                | 40         |
| Sensor Properties for Records.....                           | 41         |
| <b>MENU / RUN.....</b>                                       | <b>43</b>  |
| Stethoscope.....   | 43         |
| Camera.....  | 43         |
| IR Camera.....   | 43         |
| Gallery.....   | 43         |
| Calculator.....  | 43         |
| Update.....  | 44         |
| Help.....  | 44         |
| Screenshot.....  | 44         |
| Export All.....  | 44         |
| About.....   | 45         |
| Power Off.....   | 45         |
| <b>Speed detection.....</b>                                  | <b>46</b>  |
| <b>Analyzer.....</b>   | <b>47</b>  |
| Basic concepts.....  | 47         |
| Export Project to VA5_DISC (flash disk).....                 | 47         |
| Project List.....  | 48         |
| Project Menu.....  | 48         |
| Graphs Screen.....   | 50         |
| Measurement Definition in the Set.....                       | 51         |
| Input Buffering.....   | 56         |
| Graph Max/Min.....   | 56         |
| Buttons Modes.....   | 56         |
| Set Menu.....  | 58         |
| Meas Menu.....   | 59         |
| Edit Measurement.....  | 66         |
| Graph Properties.....  | 75         |
| FASIT.....   | 84         |
| Overall.....   | 84         |
| Spectrum.....  | 87         |
| Time.....  | 89         |
| G-demod Spectrum.....  | 91         |
| G-demod Time.....  | 92         |
| G-demod Overall.....   | 92         |
| amp+phase.....   | 92         |
| Orbit.....   | 93         |
| Filtered Orbit.....  | 94         |
| Speed.....   | 95         |
| ACMT time.....   | 96         |
| ACMT g-demod time.....                                       | 96         |
| ACMT g-demod spectrum.....                                   | 97         |
| Orders.....  | 97         |
| Order Spectrum (Order Tracking Analysis).....                | 98         |
| Phase Shift.....   | 99         |
| DC.....  | 100        |
| Frf.....   | 101        |
| Octave Spectrum, Sound Level and Equivalent Sound Level..... | 102        |
| Center line.....   | 102        |
| Smax.....  | 103        |
| Complex Smax.....  | 103        |
| Cepstrum.....  | 105        |
| Ultrasound.....  | 105        |
| Record.....  | 106        |
| <b>Route.....</b>  | <b>107</b> |

|   |            |
|---|------------|
| ADASH                                       | VA5 Pro    |
| Loading of the route to the instrument..... | 107        |
| Route creation in VA5 device.....           | 109        |
| Route Tree.....                             | 109        |
| QR.....                                     | 110        |
| Route images.....                           | 113        |
| Sensors Check.....                          | 114        |
| Measurement process.....                    | 115        |
| Route Meas Mode.....                        | 115        |
| Route Status.....                           | 116        |
| Last and reference values.....              | 116        |
| Manual Entry.....                           | 117        |
| Notes.....                                  | 117        |
| Speed in the Route.....                     | 118        |
| Linear speed.....                           | 119        |
| Limits.....                                 | 121        |
| Export to VA5_DISC.....                     | 122        |
| <b>Runup.....</b>                           | <b>123</b> |
| Runup Measurement.....                      | 123        |
| Trends.....                                 | 124        |
| Trend Menu.....                             | 126        |
| <b>Recorder.....</b>                        | <b>127</b> |
| Project List.....                           | 127        |
| Project Menu.....                           | 127        |
| Record Settings.....                        | 129        |
| Recording.....                              | 130        |
| Record Preview.....                         | 131        |
| Export to wav Settings.....                 | 132        |
| Temporary record.....                       | 134        |
| <b>Balancer.....</b>                        | <b>135</b> |
| Planes and Points.....                      | 135        |
| Project.....                                | 135        |
| Project List.....                           | 135        |
| Project Menu.....                           | 136        |
| Balancer Settings.....                      | 137        |
| Basic Settings.....                         | 137        |
| Units Settings.....                         | 139        |
| Rotor Settings.....                         | 140        |
| Single Plane Balancing.....                 | 141        |
| Dual Plane Balancing.....                   | 148        |
| Balancing Errors.....                       | 154        |
| Balancer Menu.....                          | 155        |
| <b>Advanced Balancer.....</b>               | <b>157</b> |
| Project.....                                | 157        |
| Project List.....                           | 157        |
| Project Menu.....                           | 158        |
| Balancer Settings.....                      | 158        |
| Basic Settings.....                         | 159        |
| Units Settings.....                         | 160        |
| Balancing Procedure.....                    | 161        |
| Balancing Errors.....                       | 168        |
| Balancer Menu.....                          | 168        |
| <b>FASIT.....</b>                           | <b>169</b> |
| Adash Vibration Limits.....                 | 169        |
| FASIT Settings.....                         | 171        |
| Sensor Settings.....                        | 171        |
| Units.....                                  | 172        |

|  |            |
|--|------------|
| ADASH  | VA5 Pro    |
| Measurement.....                             | 172        |
| FASIT screen.....                            | 172        |
| <b>Stethoscope.....</b>                      | <b>174</b> |
| The delay of audio output.....               | 174        |
| Playback Settings.....                       | 174        |
| <b>Lubri - the greasing control.....</b>     | <b>176</b> |
| Two Ways How to Mount a Sensor.....          | 176        |
| Procedure.....                               | 177        |
| <b>Octave Analysis.....</b>                  | <b>179</b> |
| Measurement Settings.....                    | 179        |
| Measurement.....                             | 180        |
| Octave Analysis Algorithm.....               | 180        |
| <b>Bump Test.....</b>                        | <b>181</b> |
| Settings.....                                | 181        |
| Amplitude Trigger.....                       | 181        |
| Response Spectrum.....                       | 182        |
| Analysis.....                                | 183        |
| Buttons.....                                 | 184        |
| <b>ADS.....</b>                              | <b>185</b> |
| ADS project.....                             | 185        |
| Project List.....                            | 185        |
| Project Menu.....                            | 186        |
| ADS Settings.....                            | 186        |
| Views.....                                   | 187        |
| Buttons for Machine View.....                | 190        |
| Buttons for Measurement View.....            | 190        |
| <b>Ultrasound.....</b>                       | <b>192</b> |
| Sensor Setting.....                          | 192        |
| Settings.....                                | 192        |
| Measurement.....                             | 193        |
| <b>Camera.....</b>                           | <b>194</b> |
| Buttons.....                                 | 194        |
| <b>IR Camera.....</b>                        | <b>195</b> |
| Operation.....                               | 195        |
| Focus.....                                   | 195        |
| Warming Up.....                              | 195        |
| Cursor.....                                  | 195        |
| Buttons.....                                 | 196        |
| Temperature Calibration.....                 | 196        |
| IR Image Correction.....                     | 196        |
| Graph Properties.....                        | 197        |
| <b>Gallery.....</b>                          | <b>199</b> |
| Buttons.....                                 | 199        |
| Buttons for maximized IR Camera picture..... | 200        |
| <b>MCSA.....</b>                             | <b>201</b> |
| Sensors Settings.....                        | 201        |
| MCSA Settings.....                           | 201        |
| Measurement.....                             | 202        |
| MCSA Screen.....                             | 203        |
| Errors and warnings.....                     | 206        |
| One phase measurement.....                   | 207        |
| <b>A4404 – SAB and Virtual Unit.....</b>     | <b>208</b> |

|  |            |
|--|------------|
| ADASH  | VA5 Pro    |
| Installation.....                                      | 208        |
| Update.....  | 208        |
| Operation.....   | 208        |
| VA5 Virtual unit and VA5 Pro connection.....           | 209        |
| <b>Appendix A: Technical Specification.....</b>        | <b>210</b> |
| Inputs.....  | 210        |
| Measurement Functions.....                             | 210        |
| Recording:.....  | 211        |
| Balancing:.....  | 211        |
| Camera:.....   | 211        |
| IR camera:.....  | 211        |
| General:.....  | 212        |
| <b>Appendix B : Phase measurement conventions.....</b> | <b>213</b> |
| Single channel measurement with tacho.....             | 213        |
| Dual channel measurement.....                          | 216        |
| Last reminder.....                                     | 216        |
| <b>Appendix C: Symbols and Abbreviations.....</b>      | <b>217</b> |
| Inputs.....  | 217        |
| Abbreviations in Graphs.....                           | 217        |

## **Introduction: basic instructions**

The **VA5 Pro** instrument, the **A4404 – SAB (Signal Analyzer Box)** device and the **Virtual Unit** application will be described in this user manual. This chapter should clear up the difference between them.

### **VA5 Pro**

**VA5** is a portable vibration analyzer which is based on unique *Digital Signal Processing (DSP)* board developed by *Adash*.



### **A4404 – SAB (Signal Analyzer Box)**

**A4404 – SAB** is a pocket size vibration analyzer which contains input connectors for sensors. It uses the same *DSP* board as **VA5** but it doesn't contain keyboard and screen. It must be connected to a computer via USB. You need to install **Virtual Unit** application which is the same software as **VA5**. Almost all functions described in this manual work both in the instrument and in the *Virtual Unit*. You will be notified when some difference occurs. *Virtual Unit* and **A4404 – SAB** peculiarities will be described in a standalone chapter at the end of the manual.





**Before you turn on your device, you need to pay attention to the following information.**

**Ignoring any recommendations mentioned below may cause failure of the device.  
Operating with a power higher than 24 V can cause an accident.**

## **General warnings**

**Never connect higher than 30 V to the Analyzer!**

**Only suitable ICP powered sensors can be connected to the AC signal inputs.**

**If a measurement without ICP power is required, ICP power must be switched off. You can damage the external signal source, which is not protected against ICP powering.**

**AC channels - voltage higher than  $\pm 18$  V (peak) can damage the instrument.**

**DC channels - voltage higher than  $\pm 30$  V (peak) can damage the instrument.**

**Always use only original cables designed for connection with sensor.**

**Use only the original charger with the original connector.  
Never use any reduction to connect the charger with the instrument.**

**Use the charger only if the instrument is turned off. Only charge the instrument indoors, in dry environment without vibrations.**

**Long push and hold of the *Power* button evokes incorrect instrument switching off. Data could be lost.**

**If you are unsure, contact your distributor or the manufacturer.**

## **Battery Charging**

**Charge the battery only at 0 - 40°C (30 - 100 °F)!**

**Do not use the charger during measurement (higher noise).**

The socket for external charger is at the top panel. The battery LED diode lights orange during charging and lights green when fully charged.





The VA5 instrument uses Li-ION (LiON) batteries. This type of battery should not be discharged completely. If the battery is discharged below a certain Voltage, we call it deep discharging. The deep discharging shortens battery life. Charging of a deeply discharged battery takes much longer.

If the instrument is not charged for a longer period of time, then the deep discharge can occur. It is caused by self-discharging of the battery. It is also a common mistake to switch the instrument to sleep by pushing the *Power* button instead of switching it off totally. When the battery is deeply discharged, it takes much longer to charge it again. Sometimes the indicator on the charger does not light when the battery is deeply discharged – it does not mean it is not charging. Please keep the battery charging even if the indicator does not light, the indicator will start to light later.

To avoid deep discharge of the instrument, charge it regularly, even when you don't use it. We recommend you to check if it is charged every 3 months.

#### **WHAT TO DO WHEN YOU CANNOT SWITCH ON THE INSTRUMENT/ WHEN THE INSTRUMENT CANNOT BE CHARGED NORMALLY:**

- **Discharged battery**  
battery needs to be charged (charging for approximately 5 hours), the instrument can be switched on normally with the charger connected
- **Deeply discharged battery, when the instrument wasn't charged for a longer period of time**  
the instrument needs to be charged completely until the indicator on the charger starts to light green. It can take more than 12 hours. The indicator does not light from the beginning of charging process. It is sometimes not possible to switch on the instrument even with the charger connected.
- **Damaged charger**  
when the charger is connected, the indicator should start to light (green or orange color). The indicator does not light immediately only in deep discharge.
- **Sudden decrease of battery life**  
the instrument needs to be charged and discharged completely a few times (usually 2-5 times). The battery lifetime should increase this way.

# Hardware

## *Front View*



## *Top View*



## *Rear View (with IR camera connected)*

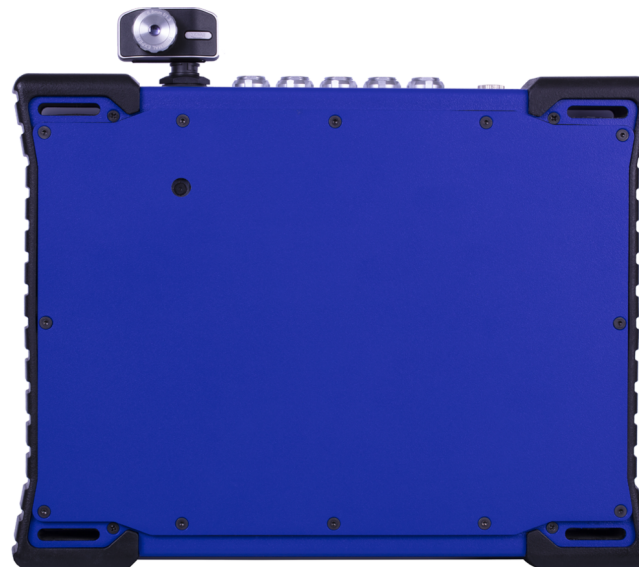

## Connection to the computer

### VA5\_DISC

All data like projects, measurements, readings, setups and so on are stored to a high capacity hard disk which is intended for internal purposes only. Furthermore, the instrument contains the **VA5\_DISC**, it is a flash memory, which is accessible from an external computer. The **VA5\_DISC** is an interface for data. For example, you save a route from **DDS** to the **VA5\_DISC**, the instrument copies it automatically to hard disk. Then you measure the route and then you export the route back to the **VA5\_DISC**. Here you can read it from computer. You don't need to export all data from the internal hard disk. Export only the data which you want to read from a computer. A detailed description how to export will be stated later in chapters about project's control for each module.

### Connection

To make a connection between a computer and an instrument (more precisely its **VA5\_DISC**), use the USB cable which is the standard accessory.



The connection to a PC is indicated by the icon located on the bottom right corner next to battery icon. For data download, you must be in the main screen.



If you are not on main screen, the **VA5\_DISC** remains accessible to the instrument processor and you cannot see it in your PC. The correct connection with the PC is announced by the message box.

**Connected to PC**  
**To prevent data loss, always use Safely Remove Hardware icon on your computer before unplugging the USB cable!**

### VAX\_DISC

You may sometimes need higher capacity interface disk than the **VA5\_DISC** (16GB). You can connect any external disk via USB. In order for the instrument to be able to recognize your disk, you must name it as **VAX\_DISC**. Use a standard USB OTG cable (see below) to allow the instrument to act as a host. Connect the small plug to the instrument's USB socket, then connect the **VAX\_DISC** to the OTG's socket. When **VAX\_DISC** is connected, the instrument prefers it over **VA5\_DISC**.

**Note!** The OTG cable is not a standard accessory of VA5 set.



## Input Channels

All input sockets are on the top panel.

The input sockets IN1, IN2, IN3, IN4 are used for AC and DC signals. The TRIG input socket is used for trigger signals, usually tacho. All sockets have several pins. It enables you to connect more signals to one socket (see wire diagrams).

The AC inputs enable you to measure max voltage peak +/-12V. The DC channels enable you to measure max +/-24V.

**NC** - not connected

**GND** - ground

**SHLD** - shielding

### **IN1 Socket**

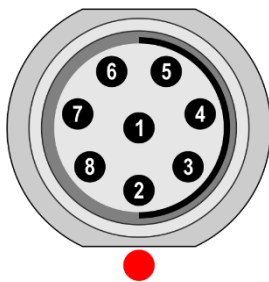

- 1 – NC or GND
- 2 – +5V/0.1A
- 3 – **DC1**
- 4 – NC
- 5 – SHLD
- 6 – +20V/5mA
- 7 – **GND**
- 8 – **AC1**

**Attention!** Pin 2 of IN1 socket (ultrasound sensor powering) is internally connected with pin 2 of TRIG socket (tacho / external probe powering).

### **IN2 Socket**

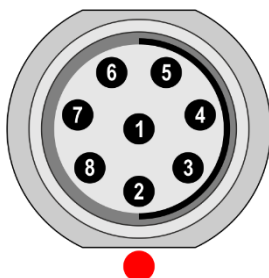

- 1 – NC or GND
- 2 – AC4
- 3 – **DC2**
- 4 – AC3
- 5 – SHLD
- 6 – AC1
- 7 – **GND**
- 8 – **AC2**

**Note!** Pay attention to the possibility of connecting all four AC channels to **IN2**.

### **IN3 Socket**

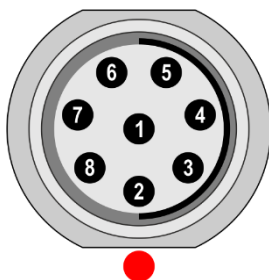

- 1 – NC or GND
- 2 – DC2
- 3 – **DC3**
- 4 – DC4
- 5 – SHLD
- 6 – DC1
- 7 – **GND**
- 8 – **AC3**

**Note!** Pay attention to the possibility of connecting all four DC channels to **IN3**.

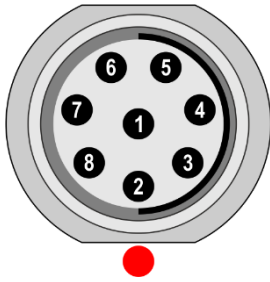
**IN4 Socket**

- 1 – NC or GND
- 2 – NC
- 3 – **DC4**
- 4 – NC
- 5 – SHLD
- 6 – +20V/5mA
- 7 – **GND**
- 8 – **AC4**

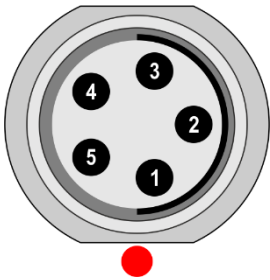
**TRIG Socket**

- 1 – TRIG
- 2 – +5V/0.1A
- 3 – SHLD
- 4 – GND
- 5 – GND

**Attention!** Pin 2 of IN1 socket (ultrasound sensor powering) is internally connected with pin 2 of TRIG socket (tacho / external probe powering).

**Standard Cable Wiring**

Standard cables which are part of the VA5 set have the sensor signal connected to the pin number 8. The second sensor wire is connected to the ground (pin 7).

**When you use this cable:**

In **IN1** socket, the signal will be measured on **CH1**.

In **IN2** socket, the signal will be measured on **CH2**.

In **IN3** socket, the signal will be measured on **CH3**.

In **IN4** socket, the signal will be measured on **CH4** (ver. 2.0 and higher).

If you want to use a tri-axial sensor, then you have to use the IN2 socket (pins 6, 8, 4) + ground (pin 7). You need a special cable for this purpose.



This box can simplify the connection of more cables to VA5 inputs. The BNC input connectors are used on the top panel for connection of 4 AC channels and 4 DC channels. There are two connectors on the side panel, which enable you to connect all 4 AC channels to IN2 input and all 4 DC channels to IN3 input. See the wiring diagram of IN2 and IN3 in previous chapter. You see that all 4 AC channels can be connected to one input IN2. All 4 DC channels can be connected to one input IN3 in the same way.

## **First steps with VA5 device**

You will learn first basic steps with VA5 device in this chapter. We mean (by basic steps) turn on/off the device or how to run sleep mode, etc.

### **Switching on**

The **Power** button is at bottom left corner of the front panel. Press and hold the button for a few seconds until a power LED begins to light. First it blinks orange for a while, then it lights blue. A keyboard backlight blinks for a while.



### **Switching off**

Use a **Power Off** in main *MENU* and confirm.

**Attention!** The *Power* button (intended for the switching on) doesn't turn the instrument off. It switches it into a sleep mode!

### **Sleep Mode**

Use the *Power* button to switch the instrument into sleep mode. The screen is off and the power consumption is lower in the sleep mode. Use the same *Power* button to wake it up again.

**Note!** You can use any button to wake the instrument up. However, notice that the button push isn't ignored by the system even in the sleep mode and the push can cause some unexpected event in the application. The reaction to the button push is the same as if the instrument was not in the sleep mode.

### **Auto Switch off**

If no button is pushed in 5 minutes from switching on, the instrument will be switched off.

### **Emergency Switch off**

This is not the correct method to switch the instrument off. Using it can cause data corruption. Use this method only in case of emergency (e.g., when the system freezes).

Push and hold the *Power* button for about 10 seconds. The instrument will switch off.

### **Capacity Warning**

If this warning message appears, you need to get free disc space by removing the measurements, routes or records, which are not needed.

90% of disc is full.  
Longer measurements not available.

# Main Screen



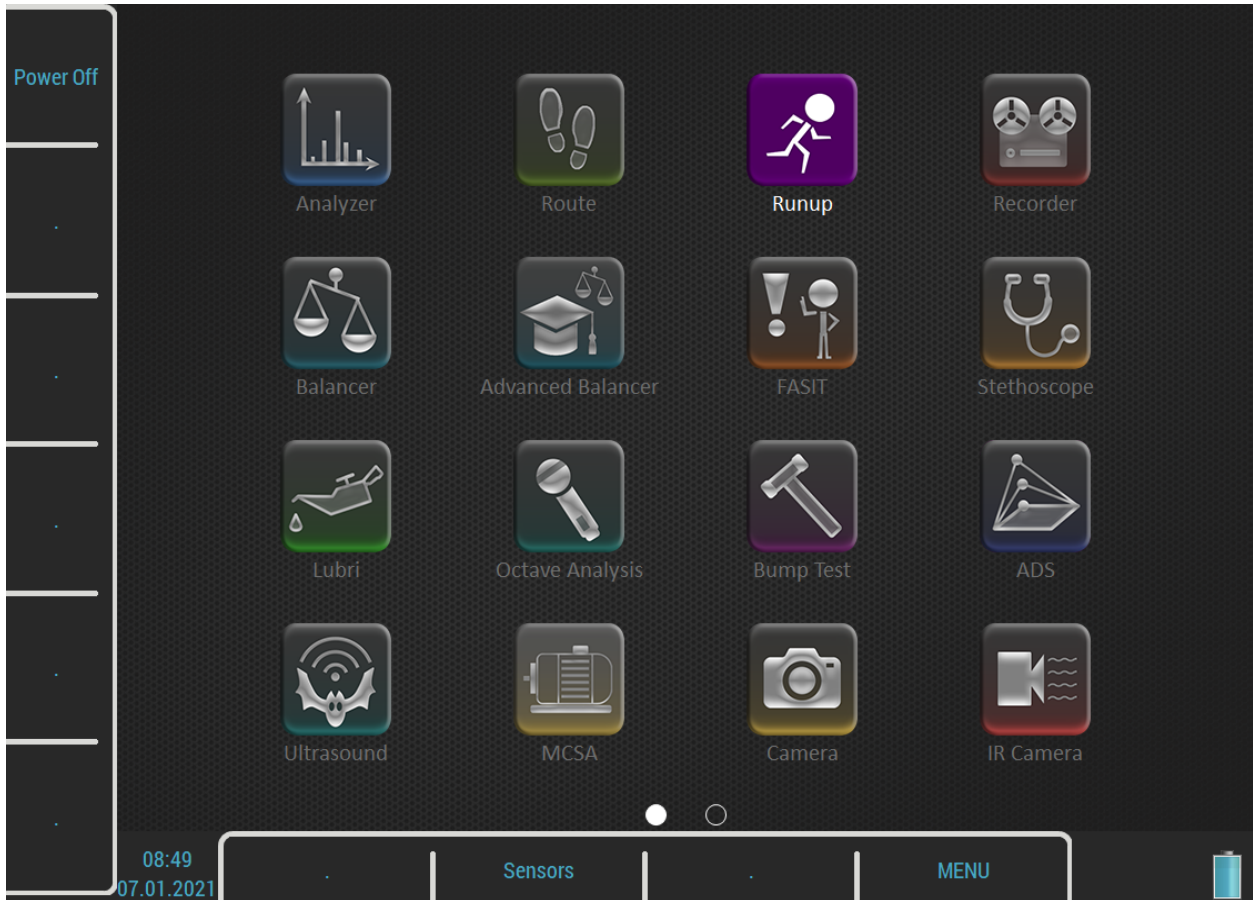



After initialization, the main screen appears. You can see a lot of icons (for modules) and buttons in the main screen. All of them are described in this chapter.



You can control the instrument by buttons around the display or by the touch screen.

## Buttons

Buttons on the right-side have following meanings:

-  **Escape**
-  **Up**
-  **Left**
-  **Right**
-  **Down**
-  **Enter**





**Backspace**



**Tab**



**Home**

The meaning of *next* buttons can vary and is always written on the screen near the button. Such approach enables you to use one button for many functions depending on current needs. You can press the button or tap the touch screen to call the function.

## Modules

The VA5 instrument contains many modules. Each module has an icon on the main screen. Select an icon using arrows or tap. Push the *Enter* button or double tap to open a module. Each module will be described in a separated chapter.

## MENU button

The **MENU** button opens an instrument's main menu. This button is available on most screens.

## Shortcuts

Left side and bottom buttons have no functionality on the main screen. They can be used for user defined shortcuts. You can define the meaning for each free button in MENU / SETTINGS / Shortcuts. The free button is marked with the "." (dot) symbol. You can also call the Shortcuts menu by pressing the free key. In this case, the dialog setups only the pressed key.

Two shortcuts are set by default, **Power Off** on button 1 and **Sensors** on button 8. You can change these shortcuts as well.

The button 8 is something special for shortcuts. A shortcut defined on this button is also available in other screens, not only on the main screen.

## PC Connection Indication



It is shown next to the battery icon when instrument is connected to PC. More detailed description about connection is in [Hardware / Connection to the computer](#).

## Touch keyboard

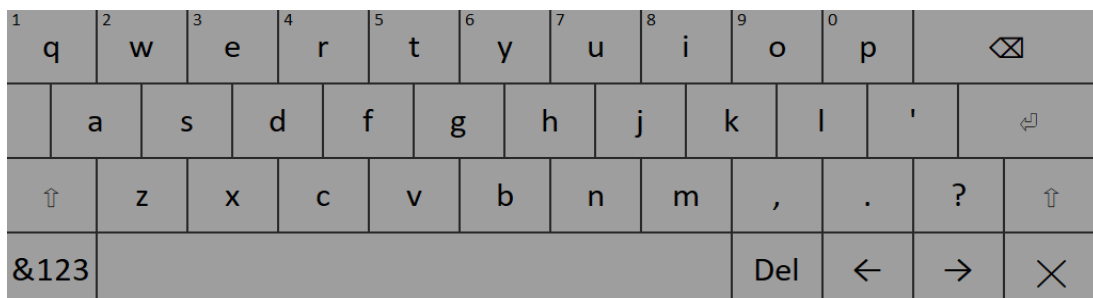

Touch keyboard is automatically opened when you enter a text. You can write by tapping keys on the keyboard.

You get an offer of alternative characters by holding a key for a while. Choose a character by moving on it and releasing.

|   |   |   |
|---|---|---|
|   | 3 | ě |
| ę | e | é |
| ê | è | ë |

There are a few control buttons:

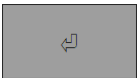

**Enter** confirms the text.



**Escape** cancels the text entering.



position.

**Backspace** moves cursor one position backwards and deletes the character on that



**Shift** switches the keyboard to enter upper case letters.



If you press the **shift** key, it becomes selected. Letters on keyboard are changed to upper case. When you enter one letter, the keyboard automatically returns to writing lower case letters.



letters.

Push the **Shift** key twice and it becomes **Caps Lock**. This keeps writing upper case



Switches the keyboard to typing numbers and symbols.

**Note!** You can also enter a number by pressing and holding a letter in the first row. Letters from the first row have a number as an alternate character. The number is written in the top left corner of the letter key.



**Delete** deletes one character on the current position.



**Left arrow** moves cursor one position backwards.



**Right arrow** moves cursor one position forwards.

## Battery Lifetime

The information about percentage of battery lifetime is displayed in the right bottom corner of the display.



Battery lifetime 75 – 100 %



Battery lifetime 50 – 75 %



Battery lifetime 20 – 50 %



Battery lifetime 8 – 20 %



Battery lifetime 7 %



Battery lifetime under 7 %. Instrument is switched off under 3 %.

## How to work with menus

You have to define many parameters for using the instrument. All those definitions are provided by menu items and windows. The procedure for operation with all is the same. We describe it in one example, the sensor properties definition.

### Item Selection

Push the **MENU** button to open the instrument's main menu. Use arrow buttons and *Enter* or double tap an item to select it. Select and open the **Sensors** menu.



Next, open any AC sensor menu.

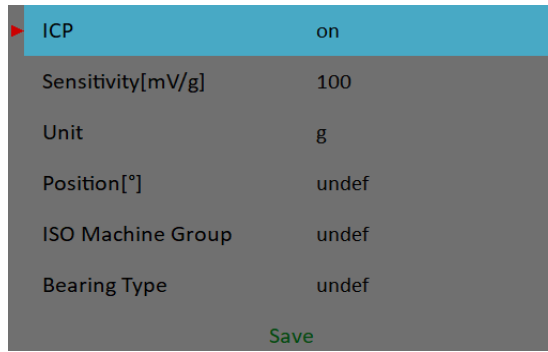

### Value Selection

Use up and down arrows to highlight an item, e.g., **Sensitivity**. Then push *Enter* or right arrow. Alternatively, you may tap the parameter you want to setup to open a submenu with possible values. Select a value by tapping or pushing *Enter*.

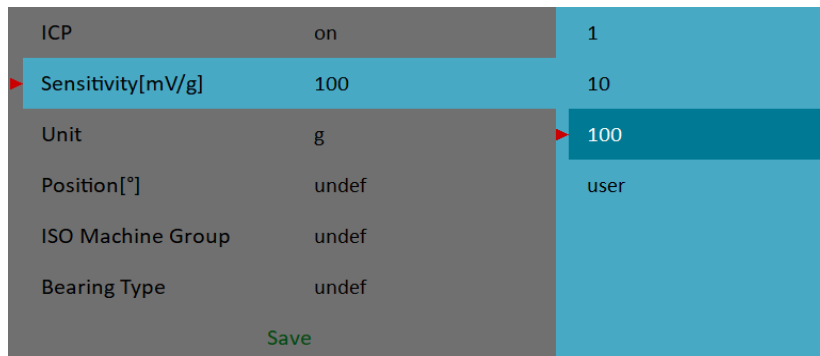

### User Defined Values

You can select predefined sensitivity or you can enter a number (for example, 45 mV/g). Select the **user** item. A text entry dialog opens.

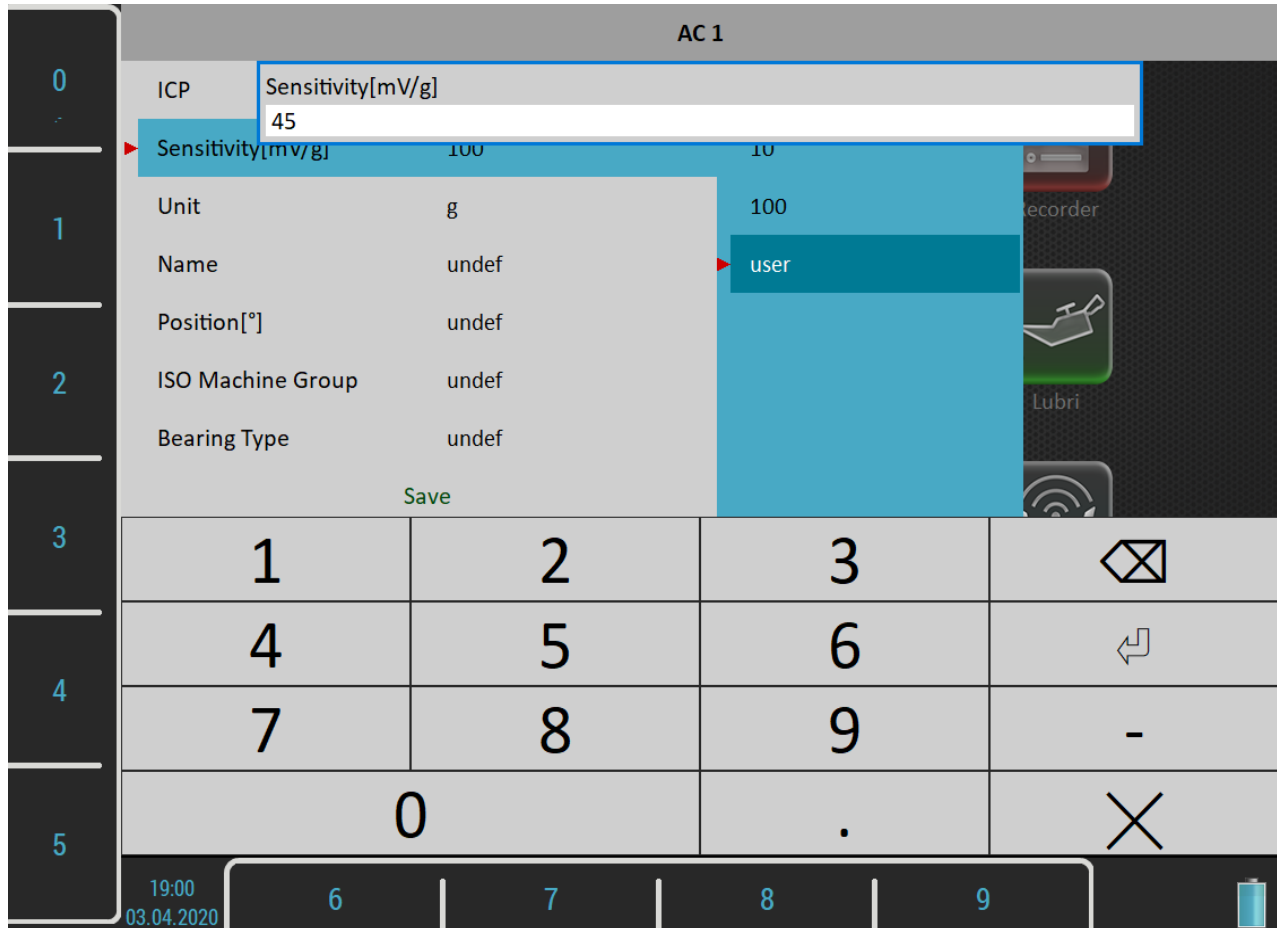

You may enter the number using buttons around the display. Decimal point or minus symbol are defined by several pushes of the **Zero** button. Use the **Backspace** button to delete entered characters. Use the **Enter** button to confirm the value or the **Escape** button to leave without any change. You may also enter the number using touch keyboard.

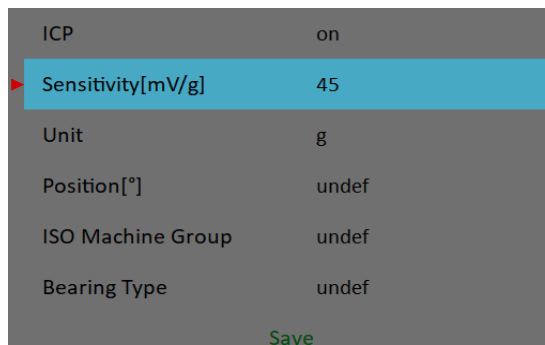

As we mentioned the value entry, the text also has to be entered in some menu items. The screen looks similar to the numerical screen. The only difference is the characters selection on buttons. It works like mobile phones keypad. For the second character selection, you must press the button two times.

### Values Confirming

The last item of all menus is **Save**. When you select this item, the menu closes and all values you have set will be saved. The **Save** button at the top left also has the same meaning. When the **Escape** button is used, then the menu is closed without saving anything.

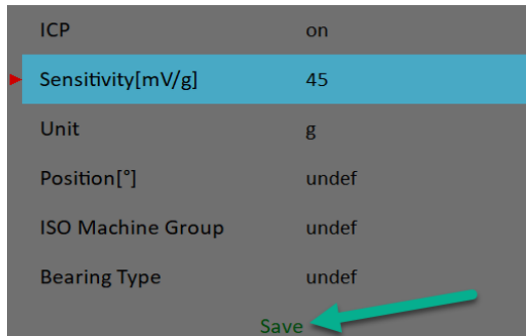

## How to work with lists

### Multi-selection of Items

Sometimes you may need to work with more items together. The usual example is deleting more items in one step.

The left **Multi on / Multi off** button enables you to select more items at once. The text of the button indicates which mode is just active. Push the button to change the mode. When you move in the list by arrows and the multi-selection is on, you can select (or unselect) more items. The *Escape* button cancels all selections.

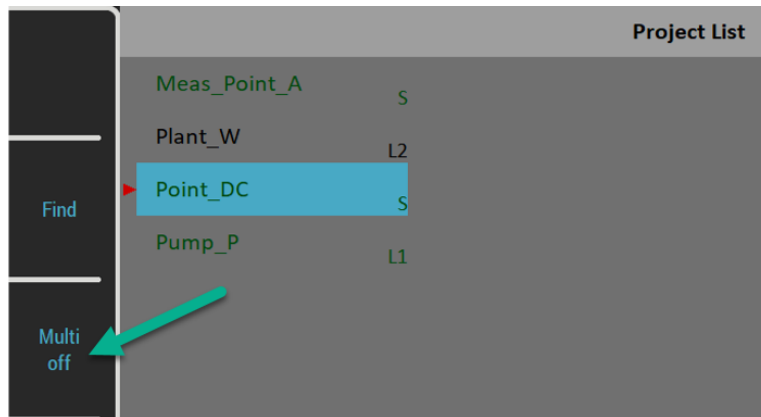

### Searching an Item

If the list is too long or you know the name, then use the **Find** button. Enter the name or part of the name and confirm.

# **MENU**

Push the **MENU** button. Instrument's main menu is separated into two parts. Items in the **SETTINGS** part are used for opening next menus and items in the **RUN** part activate some tasks.

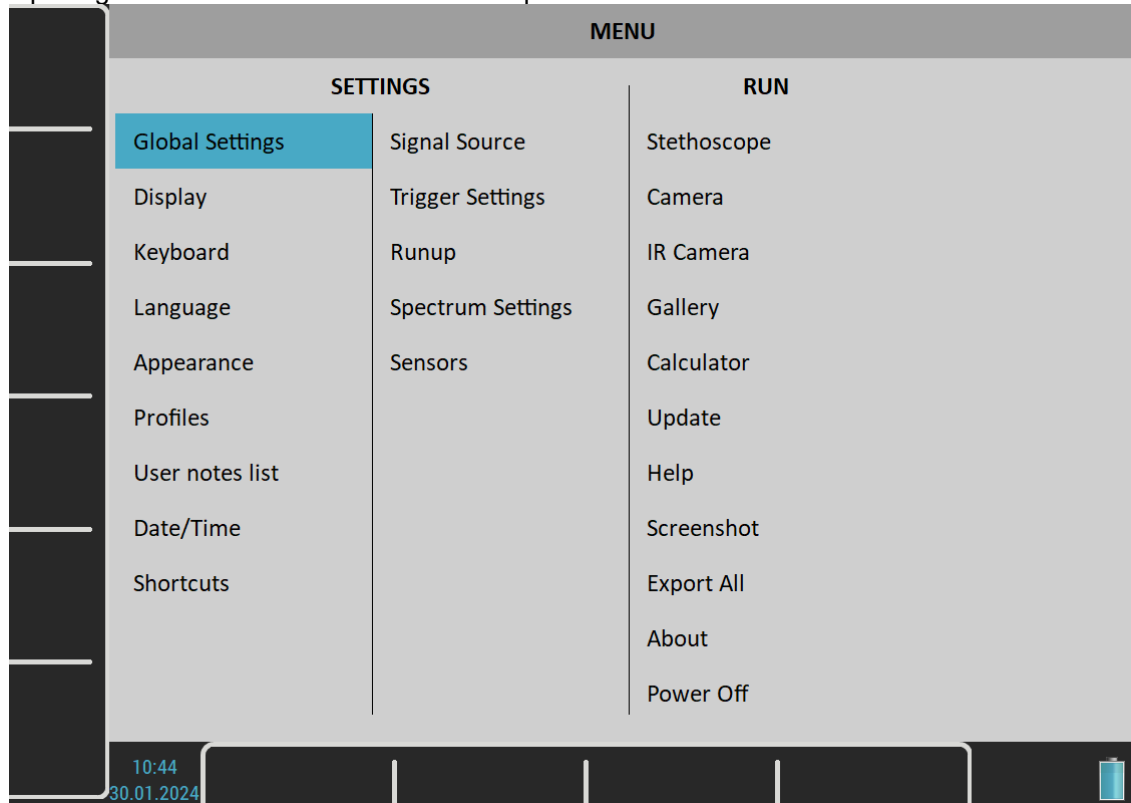

## **MENU / SETTINGS**

This section describes particular menus. Parameters descriptions also contain lists of possible values. Default values will be underlined.

### ***Global Settings***

#### ***Display Route Values***

on, off

When you want to go faster during the route and you do not want to look at measurement results after each point, then set it to **off**.

#### ***Route Autosave***

on, off

When set to **on**, the data are saved after taking measurement at each point by itself. When set to **off**, you have to save them manually.

#### ***Route Auto Forward***

on, off

After saving values, the screen with results automatically closes and a list of points appears. A next measurement point is selected. The necessary condition is, that all measurements from the last point are taken and correctly saved.

#### ***Check Route Sensors***

yes, no

Each point in the route contains the sensors setting, which is defined in *DDS*. The instrument also contains the sensors setting (menu Sensors). Both settings are compared for each point during the route readings. When the sensor setting in point is not equal to the sensor setting in instrument, then the “**Used sensor**” window appears. It is the warning to the user. This check can be turned off by setting **no**.

Used Sensor  
on AC1: 100 mV / g, ICP on

#### ***Display Small Values***

on, off

When you are interested to see values under 0,001, then set it to on and the values will be displayed in scientific notation (for example, 5.26e-6). Otherwise, the 0 (zero) will be displayed for small values.

#### ***Stop if ICP Error***

on

The measurement is stopped when ICP error occurs.

off

The measurement continues, ICP error is only informative.

#### ***Units***

metric, imperial, both

Units available in menus.



**Frequency unit**Hz, RPM, CPS, CPM**Speed unit**Hz, RPM, CPS, CPM**Power/Line Frequency**

It is used for *Elect* value in synch table, which is displayed for spectra ([Synch Table](#)).

**Phase range**(-180, 180), (0, 360)

Range of phase values

**Displayed Spectra in Cascade**32, 128, 256, 512, 1024

Number of displayed spectra in waterfall (cascade) graph. It is not the number of measured spectra!

**Align Graphs**on, off

If more graphs of the same type are displayed, then the Zoom and Cursor function of all graphs can be aligned.

**Graph Grid**on, off**Cursor Type**linear, maxs

This item must be explained in depth. The graph width (for example, spectrum frequency axis) is displayed on approx. 600 screen pixels. But the spectrum could have 25600 lines and then 42 lines are displayed in one pixel line ( $42=25600/600$ ). This number of lines in one graph pixel is different for other total line number and used zoom. In the older instruments we used the cursor movement procedure by lines. It means that the cursor moves inside one pixel without any real move on the screen. The users complained about it. Now, we use another procedure. The cursor moves by pixels, not by lines. In each pixel, there are more lines hidden and the cursor must display one specific line. What line should we use? When the Cursor type is set to **linear**, then the step of the cursor movement is the number of lines in one pixel. When the **maxs** is set, then the cursor always moves to the maximum line which is contained in one pixel.

**Record analysis speed**fast, real time

A record could be analyzed in two ways. Let's suppose the record length is 300 sec, it could be a run up record for example. You want to measure the amp+phase measurement during the record. If you want to watch the continuous results, then select the **real time** mode and the processing of record will take 300 sec (the analyzing time is the same time as the recording time was). If you want to save results to the memory and not watch them on the screen, then select **fast** mode. The analyzing time will be much faster than 300 sec. You can also imagine that it is like a tape recorder. You can push the button play (real time) or rewind (much faster). The instrument also enables you to analyze a record in fast (rewind) mode. For example, it enables the analysis of 1 hour of data in several seconds.

**Record Analysis Start**continue, begin, again, ask

These options are used when the record is selected for analysis.

It would be better to use an example for explanation. For example, we use a record with a length of 60 sec. We define time signal measurement with a length of 8 sec. It means that when we push the Start button, the reading takes 8 sec and the position of the cursor moves by 8 sec in record.

**continue:** The next reading will start at the end of last reading.

**begin:** The next reading will start at the beginning of record.

**again:** The next reading will start at the beginning of last reading.

**ask:** You select any option before the reading.

When you moved the cursor manually, the next reading will always start from that position.

## Wav Encoding

### PCM, 24 bit, PCM, 16 bit

This is a setup of encoding for wav exports. The PCM is the shortcut for pulse-code modulation which is the most common way to encode signal into wav format. The number behind the PCM shortcut represents the number of bits per sample or bit depth.

The VA5 instrument uses 24 bit A/D converter, therefore 24 bits per sample is the default bit depth for the wav export. However, some software doesn't allow to process this bit depth and then the more common 16 bits per sample encoding can be used.

**Note!** The sample rate of the wav is the same as the sampling frequency of the exported signal and cannot be changed in the instrument. If you need to change it you need to use a 3<sup>rd</sup> party application to resample the exported wav (e. g., Audacity).

## Angles Counting

### with rotation (<sup>°</sup>WR), against rotation (<sup>°</sup>AR)

You can define the direction of angles (phases). The selected choice is then signed behind degree mark as WR (with rotation) or AR (against rotation).

**Note!** Although almost all degree symbols in the application are labeled with WR or AR mark you don't see this in the manual because many of the screenshots were taken before Angles Counting was implemented.

#### With rotation:

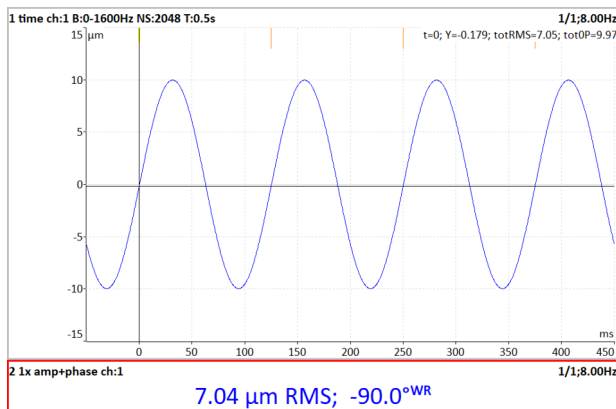

#### Against Rotation:

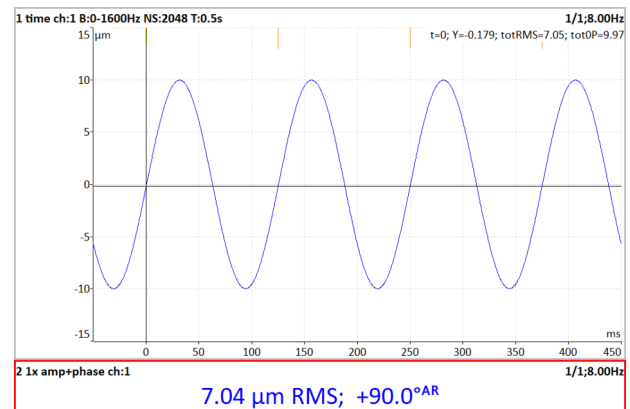

On the pictures above, you can see the time waveform with tacho marks. The tacho mark comes 90° before the maximum of the signal in the direction of rotation. If we choose **with rotation**, then we say the tacho mark is 90° before the signal maximum and thus the angle (phase) is **-90°**.

In case of **against rotation**, we say the signal maximum is 90° behind the tacho and the angle is **+90°**.

The main use of this parameter is in balancing. Some users are used to count angles with rotation and other users want to count against rotation. The instrument enables you to set your required direction.

**Warning!** By changing this value, all angles (phases) become opposite. Therefore, do not change it between readings if you want compare phases.

## Display

Not for Virtual Unit!

## **Brightness**

Display brightness settings

### **Enable Touchscreen**

yes, no

### **Display Turn Off [minutes]**

It is the value when display will be turned off. You can set it to number value (in minutes) or to value 'Never'. This parameter is set to 5 minutes by default.

## **Keyboard**

### **Keyboard Backlight**

on, off

The keyboard backlight is always off after instrument's startup. This setup is not saved.

## **Language**

### **Language**

Select your language.

## **Appearance**

### **Interface Style**

**Note!** For Virtual Unit only!

**old (VA4 I), old (VA4 II), new (VA5)**

You can choose which user interface the *Virtual Unit* uses, **VA4** or **VA5**. The change takes effect after the application restarts.

### **Use Right Buttons**

**Note!** Not for *Virtual Unit*!

yes, no

You can turn the right buttons on the display and then push them on the touch screen like in *Virtual Unit*. The change takes effect after the application restarts.

**Attention!** The useable area of the display decreases while using the right buttons. The PC connection icon is not visible.

### **Background Color**

black, white

Background color of graphs

## **Profiles**

All instrument parameters can be saved to the **Profile**. It is useful, for example, for saving of sensor sensitivities.

### **Save settings to "just opened profile name"**

Save the parameters to the currently opened profile (updates the profile).

**Note!** You have to create and open a profile otherwise this item is not visible.

### **Save settings as new profile**

Save the parameters to the new profile (after name entry).

### **Factory**

Open the factory default profile.

### **List of saved profiles**

Select an existing profile. The **Delete** button removes the selected profile.

### **User Notes List**

You can create text notes in the instrument and attach them to various items, e. g., to route points. There are three ways how to enter a note text.

1. Enter the note text manually.
2. Select a predefined note from **Factory notes** set.
3. Select a predefined note from **User notes** set.

The user notes set is created and edited by the user here, under the *User Notes List* menu item.

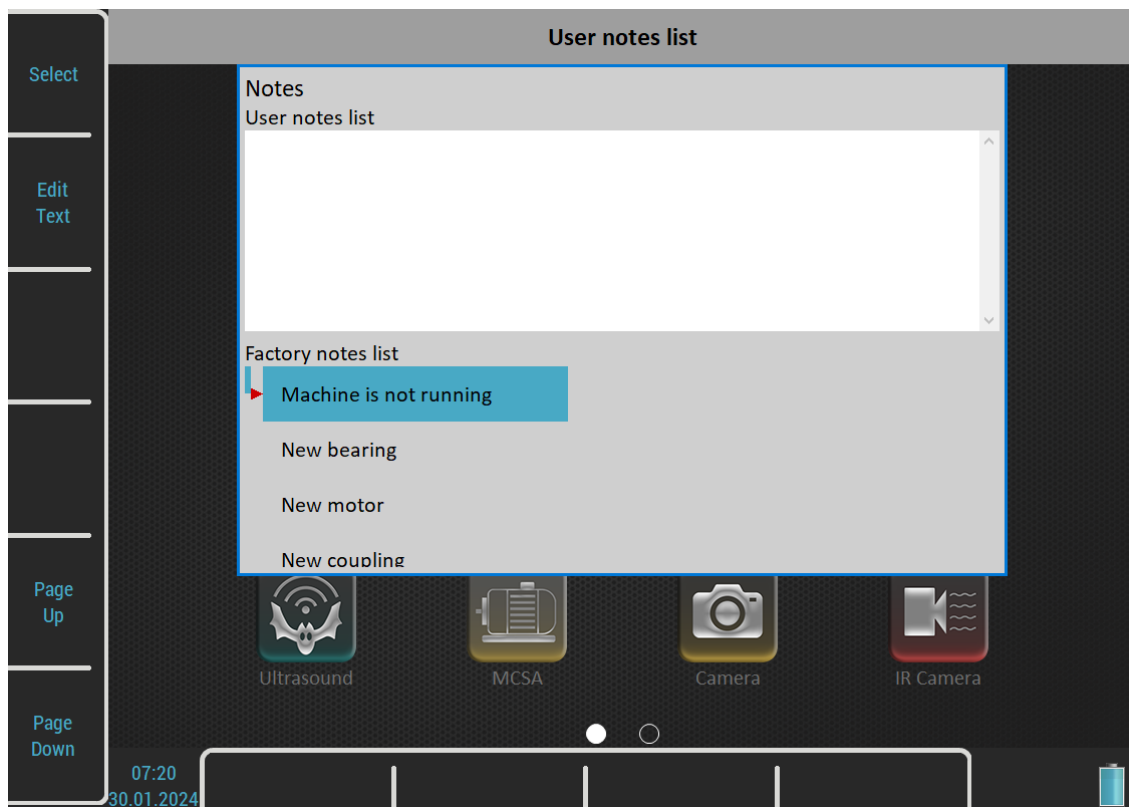

The list of existing *User notes* (now empty) is in the upper half. Predefined *Factory notes* are displayed in the lower half.

Because the user usually wants to use the *User notes* only, you can copy any factory note to the user notes. Select it by arrows and push the **Select** or **Enter** button or double tap it.

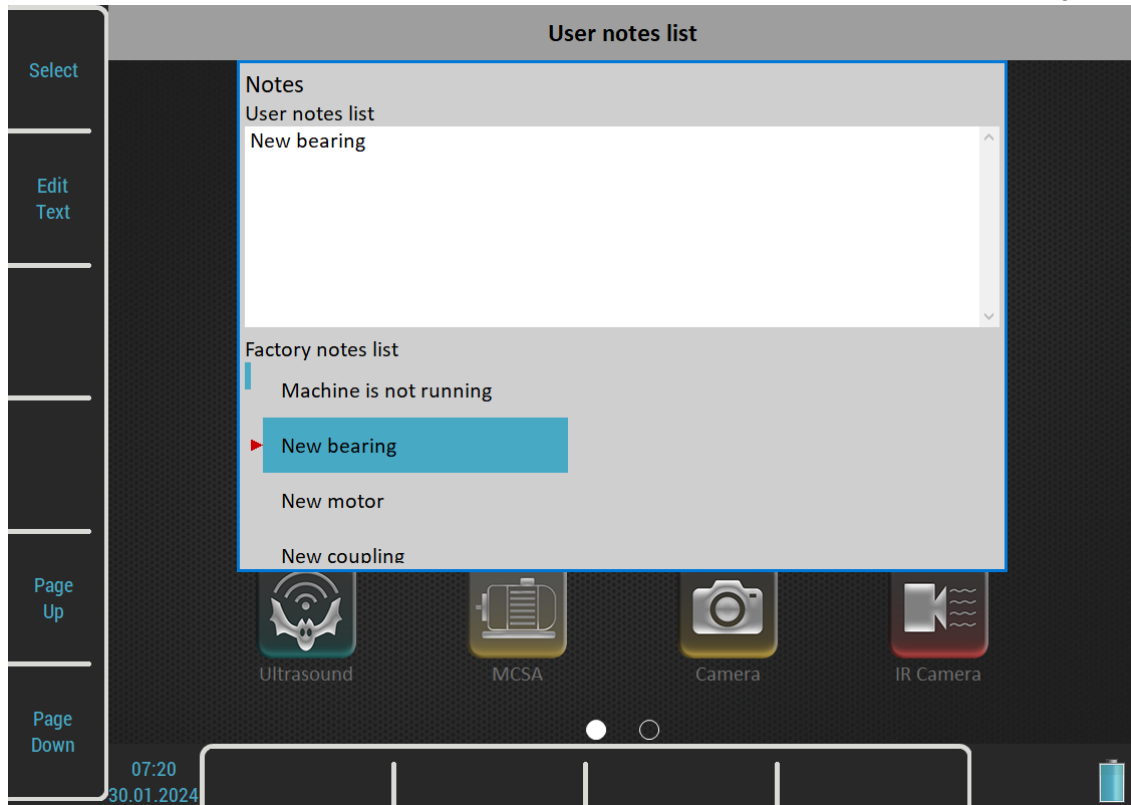

If you want to create your own note, then push the **Edit text** button. Enter your note manually. Each line in text is one note. Push the **Enter** button to add a new line.

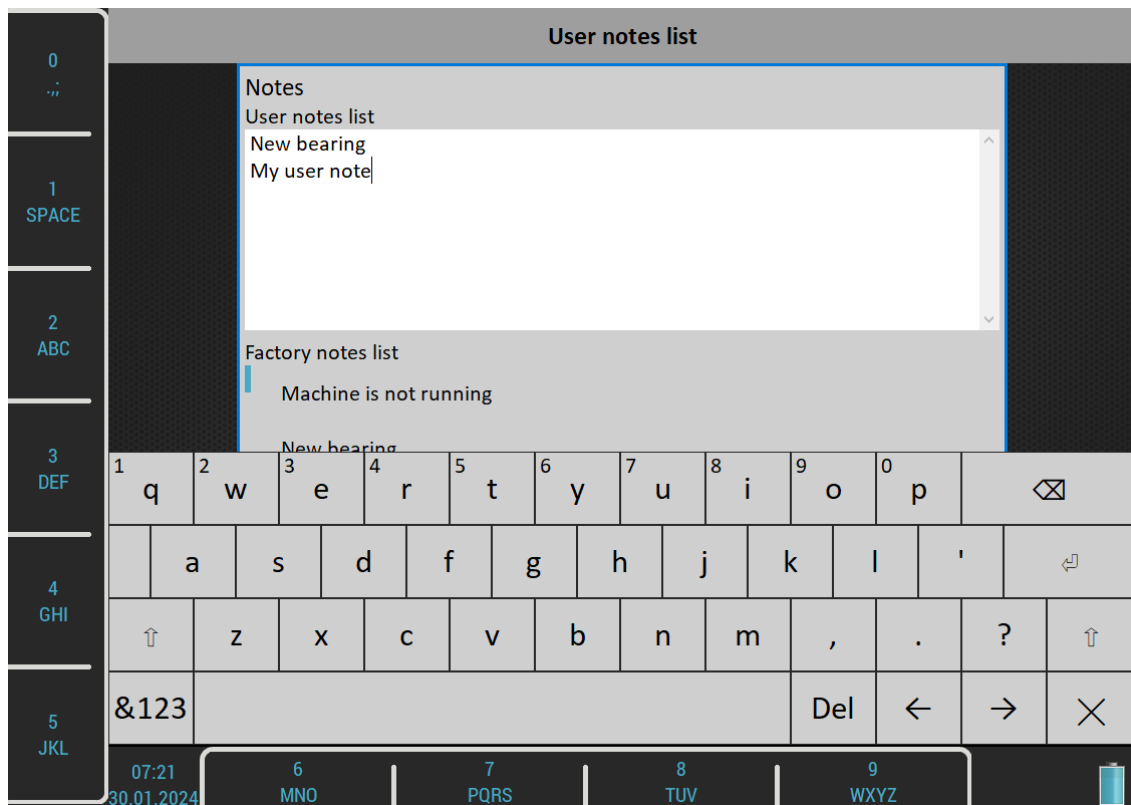

Push the *Escape* button to skip back to the *Factory notes* list.

Push the *Escape* button when *Factory notes* list is active to close the dialog. The “Save changes” question will appear. Confirm if you want.

## **Date/Time**

### **Date format**

**yyyy/mm/dd**

**dd.mm.yy**

**mm/dd/yyyy** (the a.m./p.m. is used)

### **Year, Month, Day, Hour, Minute, Second**

Set the current date and time.

## **Shortcuts**

Set the shortcuts for buttons.

## **Signal Source**

The measurement can be taken from **LIVE** channels or from *record* (see [Recorder](#) chapter for understanding). All *records* saved in the instrument's memory are displayed in the *Signal Source* list below the **LIVE** item.

## **Trigger Settings**

Parameters for measurement's triggering are entered in this menu.

### **Analyzer Trigger Mode**

Measurement's trigger control for Analyzer module. It is also used in Octave Analysis module.

#### **single**

Only one *reading* of all *measurements* in a *set* is taken and displayed.

#### **retrig**

When you use the analogue oscilloscope, you always see the current new signal on the screen. This means the similar thing. The measurement is repeated until you push the *Stop* button.

### **Runup Trigger Mode**

Measurement's trigger control for Runup module. How often the data will be taken has to be defined.

**Attention!** In the Runup module, new measurement can begin after all measurements in a set are finished (with one exception, **asap all** mode).

#### **asap**

The next measurement is taken immediately after the previous measurement without any delay.

#### **manual**

The user begins the next measurement manually (by pressing the *Enter* button).

#### **speed**

The next measurement is taken when the speed is significantly different from the previous measurement speed. The user defines what is a significant change in the **Speed change** item.

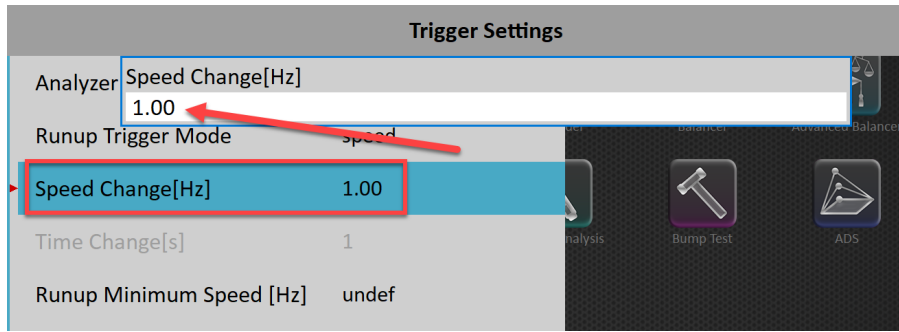

**time**

All measurements are taken with the same time interval between them. The time interval length is defined in **Time change** item.

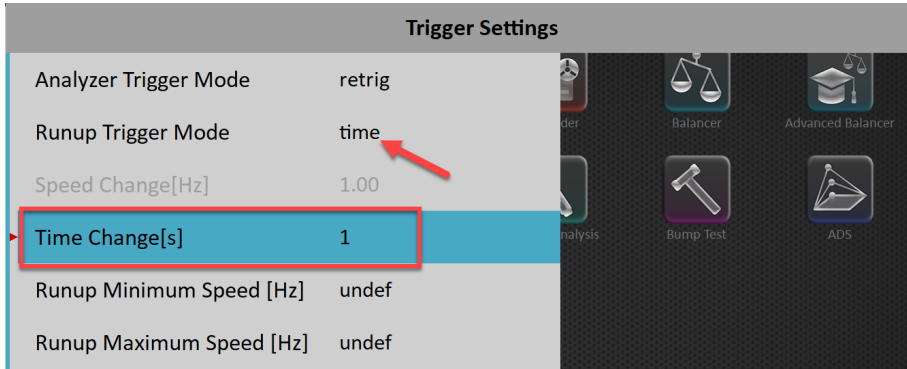

**time or speed**

This option is the combination of speed and time. The next measurement is taken when time or speed change occurs.

**asap all**

Unlike the previous trigger modes, the *asap all* mode enables **all** measurements to be taken as soon as possible. This means, the next reading of each measurement is taken immediately after the previous one. All previous modes wait for all measurement in a set to be completed before a retrig can occur. The *asap all* mode can retrig each measurement separately as soon as possible without waiting for other measurements in a set to be completed.

The following example shows the difference between the *asap* and *asap all* mode. We take three measurements with the length of 1 second, 4 seconds and 8 seconds. The first figure shows the *asap* mode. You can see three measurements, which takes 1, 4 and 8 seconds. The saving interval of all measurements is 8 seconds because the shorter measurements always wait for the longest measurement to be completed. The second figure shows the *asap all* mode where all measurements are taken as soon as possible.

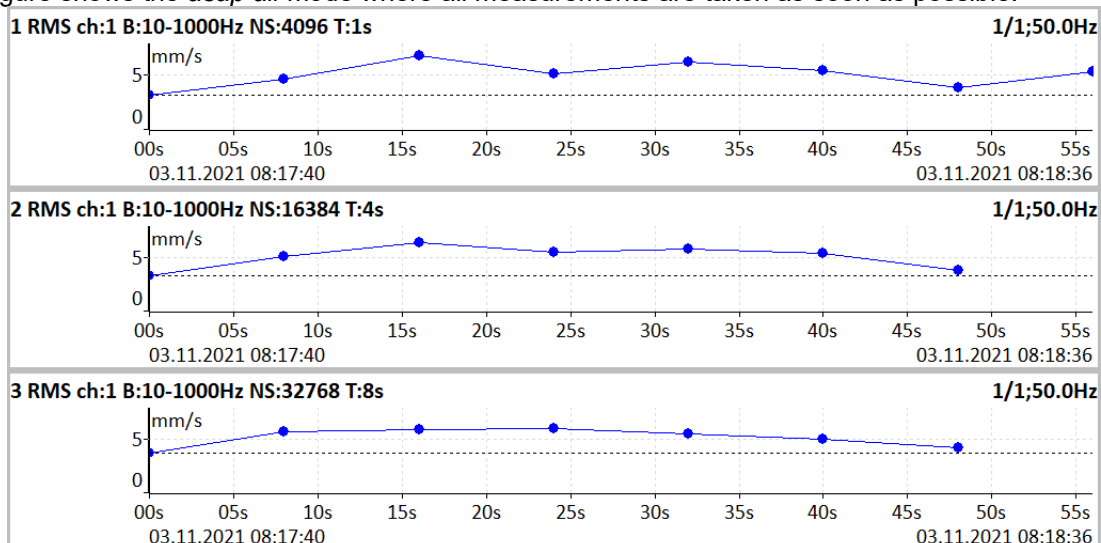

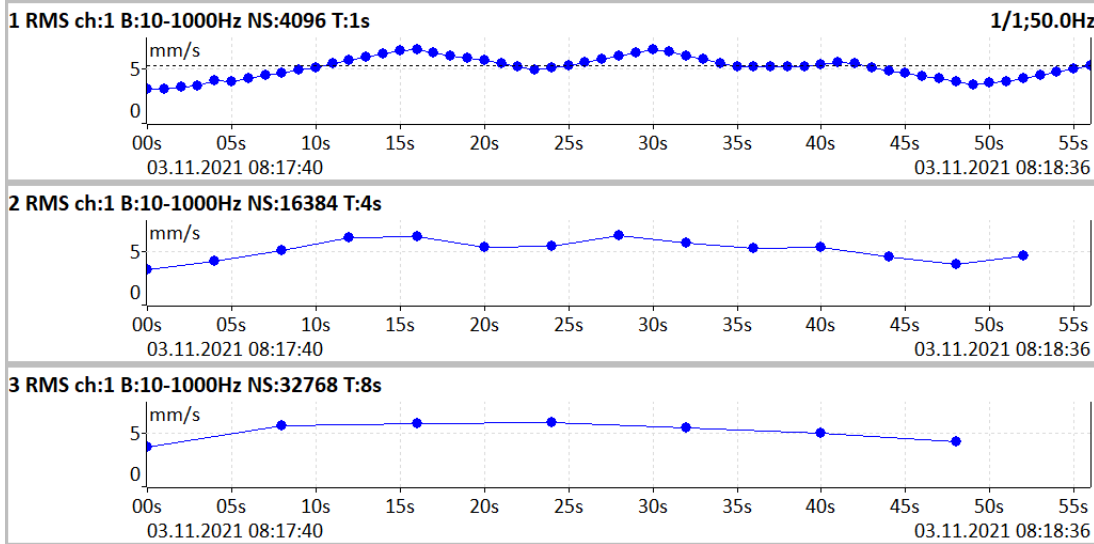

**Note!** When the *measurement process* waits for retrig event, a “**Waiting for retrig**” window appears. The text informs you which event is expected.

Waiting for manual retrig  
Press enter for retrig

Waiting for time or speed retrig  
10 s or 1.00 Hz

### Speed Change

See the [Runup Trigger Mode](#) item.

### Time Change

See the [Runup Trigger Mode](#) item.

### Runup Minimum Speed, Runup Maximum Speed

#### undef, user

Runup measurements are taken only if the current speed is greater than the *Runup Minimum Speed* (if defined) and less than the *Runup Maximum Speed* (if defined). If the condition is not met the measurement is not running and a “**Waiting for runup speed**” window appears with the limit values as a note.

**Note!** You may define both values or just one of them.

Waiting for runup speed  
<20;50> Hz

Waiting for runup speed  
<undef;50> Hz

Waiting for runup speed  
<20;undef> Hz

In the following figures, you can see the difference between a measurement with undefined runup minimum and maximum speeds (figure on the left) and a measurement with runup speeds set to 20Hz and 50Hz (figure on the right). As you can see, values greater than 50Hz and less than 20Hz are missing on the right figure. The example shows speed values. However, all measured data types are controlled by the speed value.

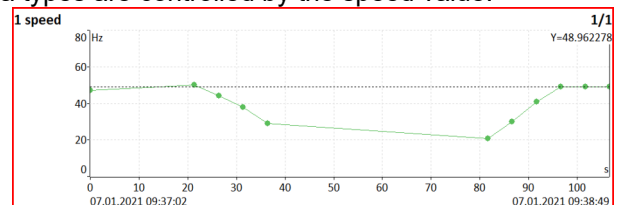
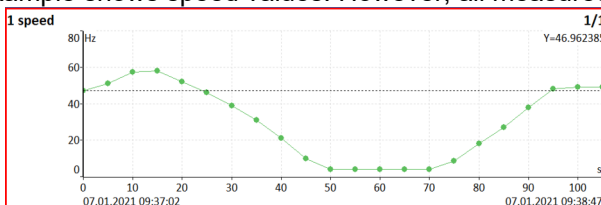

### Trigger Source

Every measurement must be triggered (it means started). When you press the *Enter* button for taking the measurement, you run only the initialization. When everything is ready to take the data, then the *Trigger Source* item is applied.

In Runup mode, the frequency of measurements is controlled by [Runup Trigger Mode](#) at first. Then the *Trigger Source* is applied.



**freerun**

Measurement is triggered immediately after initialization without waiting for anything.

**external**

Measurement is triggered when the value of the external signal on TRIG input crosses the [Trig Level \[V\]](#) value defined in [Tacho / External](#). Such signal may be generated, for example, when the machine starts to work.

**Attention!** If the external trigger source is set, a tacho probe is not supposed to be connected to the TRIG input. Therefore, in this case, no speed is evaluated. No speed dependent measurements like order analysis cannot be measured. Furthermore, no speed value is stored in data headers.

**manual**

Measurement is triggered after pressing the *Enter* button. Remember that you should push the *Enter* button twice. First pushing is for initialization, second for triggering.

**manual sequential**

Similar to manual, but every *average* during averaging must be started separately. For example, when AVG is 10, then the *Enter* button must be used 10 times.

**amplitude**

Measurement is triggered when signal on the **Ampl Trig Channel** input exceeds the **Ampl Trig Level** (both are also defined in this menu). Both positive (rising edge) and negative (falling edge) levels are accepted. The signal amplitude is taken directly from sensor input, no additional filtering is applied.

Examples:

the level is set to 100mV - triggered when the raising signal goes from, for example, 99mV to 101mV

the level is set to -100mV - triggered when the falling signal goes from, for example, -99mV to -101mV

**tacho**

Measurement is triggered when signal on TRIG input crosses the [Trig Level](#) value defined in the [Tacho / External](#) menu. The tacho is special case of an external trigger. When we talk about the tacho, we mean the signal (usually like TTL) which contains one or several pulses during one rotation of the shaft. It can also be understood like a series of single external pulses.

During averaging, tacho trigger is expected for each average, unlike in external triggering where the trigger is expected only in the beginning and then all averages are measured without triggering.

**Note!** When the *measurement process* waits for a trigger event, "**Waiting for trigger**" window appears. The text informs which event is expected.

Waiting for external trigger

Waiting for amplitude trigger  
3 g / AC 1

Waiting for manual trigger  
Press enter for trigger

**Use Ampl Tacho****yes, no**

When **yes** is set, then the tacho pulses will be created by amplitude trigger level, not from a tacho probe. Set the channel and level by the same way as for amplitude trigger. Set the **Ampl Tacho Hysteresis** to 30-50% of level to avoid creation of more pulses in near times. It could happen when signal is noisy. Sometimes you need to try more percentage values to find the correct one. See pictures for understanding.

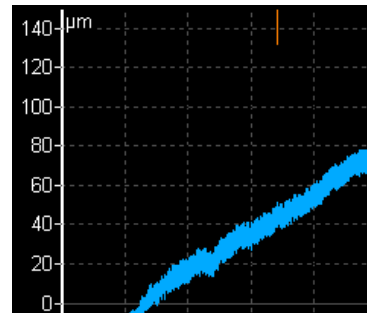
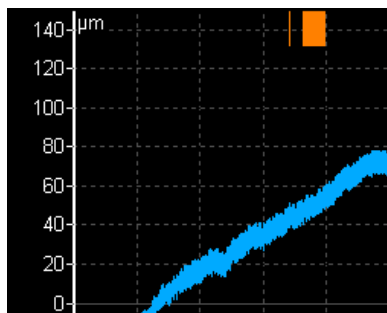

### Ampl Trig Channel

See the [Trigger Source](#) set to **amplitude**.

### Ampl Trig Level

See the [Trigger Source](#) set to **amplitude**. The value is set in the physical unit of the sensor on the selected channel.

### Ampl Tacho Hysteresis

See the [Use Ampl Tacho](#).

### Negative Averaging

**yes, no**

Negative averaging is available only with an amplitude trigger. When turned on, a reference spectrum is taken in the beginning of the measurement after device initialization. This reference spectrum is remembered and then subtracted from each calculated spectrum. This is useful when performing a bump test on a running machine. Please don't make hits during negative averaging initialization. You are noted by this window:

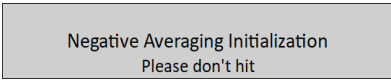

Look at the next example. On the first picture, you can see a spectrum of a hit performed on stopped machine. Exponential window is applied.

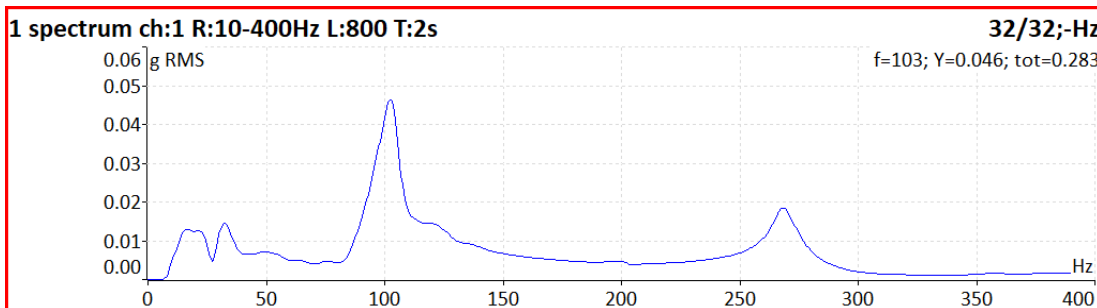

The next picture shows the hit performed on a running machine. You can see a big peak value near 50 Hz.

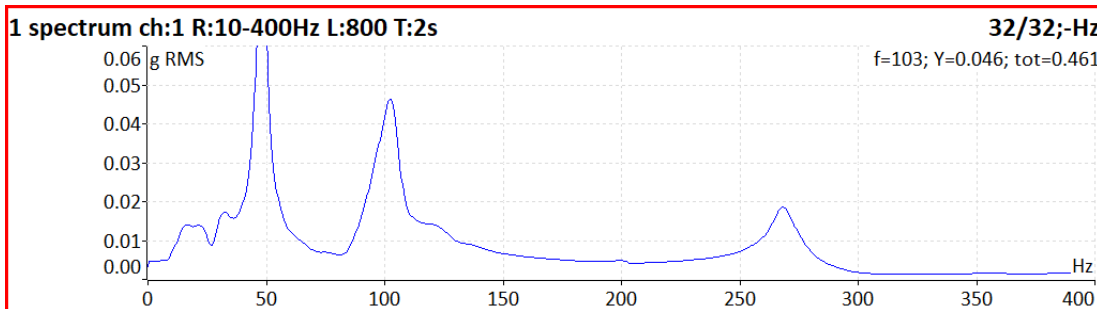

By using negative averaging, you can eliminate unwanted peaks in a spectrum, which are caused by the machine running. Not by the resonances.

**Note!** It is recommended to use averaging (make more hits) with the negative averaging to obtain the best possible result.

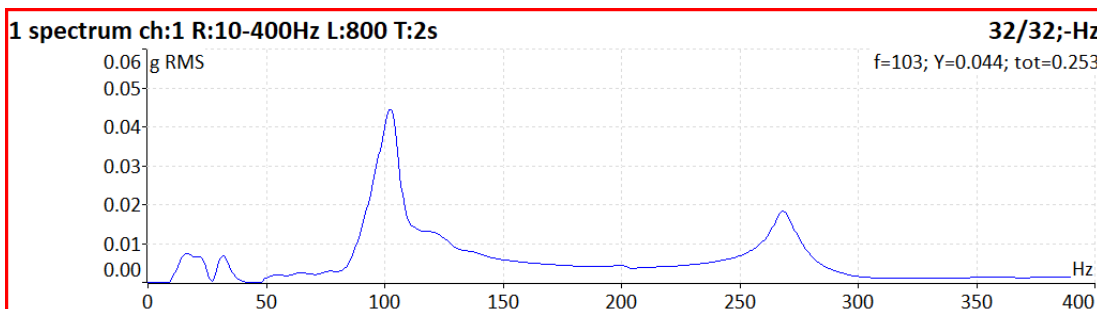

**Pretrig [%]**

[-100, 100]

Usually, the taking of measurement (for example, time signal) begins exactly from the trigger moment. But in some applications, you are also interested in knowing the signal before trigger. The required time should be defined in seconds, but in signal Analyzers it is usually defined as percent part of the total signal length. When a 1 second time signal is measured and pretrig is 25, then 0,25 seconds will be taken before trigger and 0,75 seconds after trigger. Also, a negative pretrig could be used. It means that the time signal will be taken later than the trigger pulse.

**Runup**

This menu contains parameters for Runup module.

**Max Memory Size [MB]**

It enables partial savings of runup measurement. If the size of measured data exceeds the value, then data are saved and new runup is opened.

**Time Unit**

**days, hours, minutes** – The unit of **Length** parameter (see next line)

**Length**

**undef, value** – If defined, measured data are then saved to individual files, where each file contains defined length.

**Trend Time Axe**

**relative** the time axis begins from zero

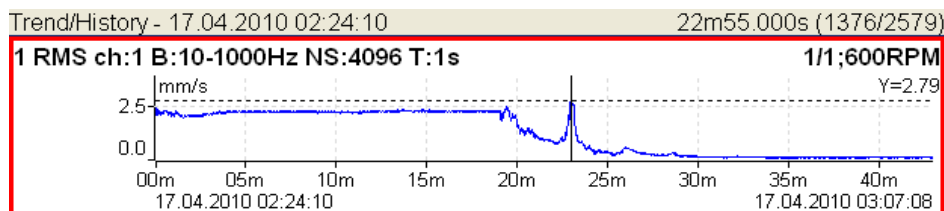

**real time** the time of measurement is displayed on time axis

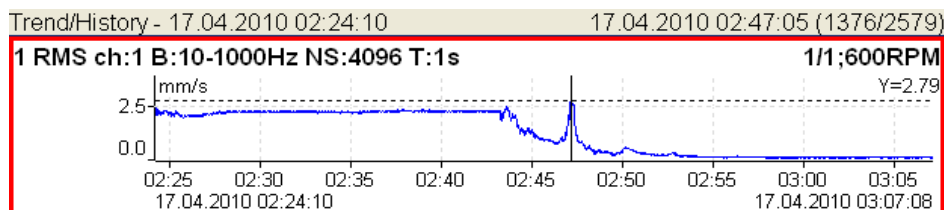
**Trend Length**

**auto, value** – The length of the trend graph (the range of X axis). It is used for Runup measurement and for Graph Properties / View Trend. When the auto is used, then all data in the trend are displayed.

**Graph Properties**

Some of [Graph Properties](#) parameters can be predefined here. Every new created graph will take these properties. Most of parameters can be later changed in the Graph Properties menu for particular graph.

**Detect Type**

**RMS, 0-P, P-P** – Default detect type for spectral amplitude values.

**Axe X**

lin, log

**Axe Y**

lin, log, dB

**Peaks list**

on, off

**Graph Lines**

continuous, discrete

**Harmonic Lines, Sideband Lines, Periodic Lines**

Number of cursor lines

**Sensors**

When you connect the sensors to the instrument, you have to tell what kind of sensors you use. Select the **Sensors** item in the main *MENU*. In the next menu, select a channel you want to define.

**AC1 – AC4**

Setting of each AC channel properties (sensor, *ISO 20816* group, bearing).

**All AC**

Setting of all AC channels together.

**All Bearings**

Setting of one bearing to all AC channels.

**All ISO**

Setting of one *ISO 20816* group to all AC channels.

**DC1 – DC4**

Setting of each DC channel properties.

**All DC**

Setting of all DC channels.

**Tacho / External**

Setting of TACHO / EXTERNAL channel properties (TRIG input).

**Settling Prolongation**

Sometimes you may need longer time for sensor settling. Set the required additional time in seconds.

## AC Sensors

AC (alternate current) sensors are used for signals, for example, vibrations. The AC sensor menu can be opened using the *MENU / Sensors / AC1 – AC4* or *All AC*.

### ICP

**on, off** – Selection of a required setting according to sensor type

**Note!** The ICP powering is available also while measuring a DC signal because some DC sensors may use it.

### Sensitivity [mV / “unit”]

**1, 10, 100, user** – Define the sensitivity value in the sensor’s physical unit.

### Unit

Select the unit according to sensor’s type.

### Name

**undef, user** – You can optionally enter a name of the sensor by choosing the **user** item. Use the **undef** item to reset the sensor name.

**Note!** The sensor’s name is displayed in Sensors main menu.

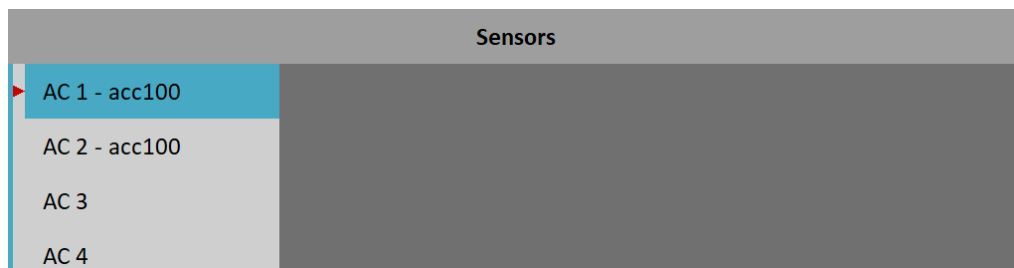

### Saving sensor

Parameters of a named sensor can be saved. After you enter the name, open the **Name** menu again. New item **save** is available now. When you choose this item, the sensor will be saved.

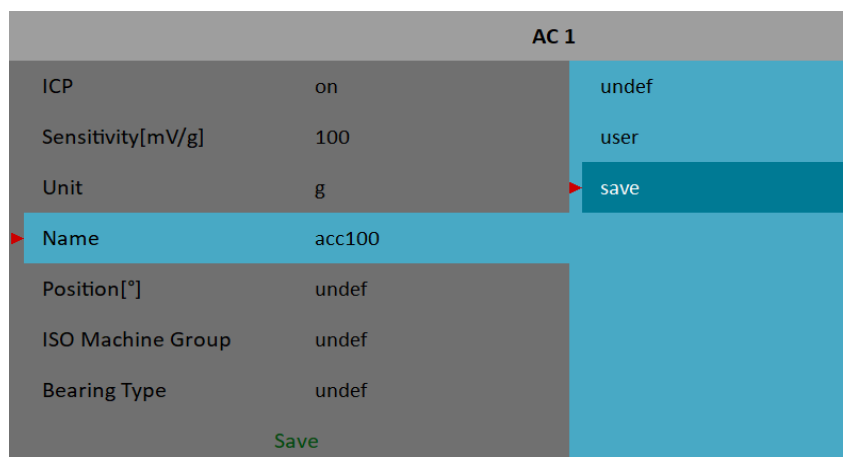

**Note!** If you want to save a sensor with a name which has been already defined, you'll be asked to rewrite its parameters.

Sensor "acc100" has been already defined.  
Rewrite its parameters?

## Loading sensors

Saved sensors are displayed on when you open the **Name** menu. Select a name of a saved sensor and press *Enter*. Its parameters are then loaded.

| AC 1              |       |        |
|-------------------|-------|--------|
| ICP               | on    | undef  |
| Sensitivity[mV/g] | 100   | acc100 |
| Unit              | g     | acc500 |
| Name              | undef | geofon |
| Position[°]       | undef | user   |
| ISO Machine Group | undef |        |
| Bearing Type      | undef |        |
| Save              |       |        |

**Note!** If you choose the **user** option and then enter a name which has already been saved (e. g., **acc500**) you'll be asked to load its parameters.

Sensor "acc500" has been already defined.  
Load its parameters?

## Deleting sensor

Select a sensor which you want to delete. Open the **Name** menu again. New **delete** item appears now. Select this item and press *Enter*. The sensor will be removed from the list.

| AC 1              |        |        |
|-------------------|--------|--------|
| ICP               | on     | undef  |
| Sensitivity[mV/g] | 100    | acc100 |
| Unit              | g      | acc500 |
| Name              | acc100 | geofon |
| Position[°]       | undef  | user   |
| ISO Machine Group | undef  | delete |
| Bearing Type      | undef  |        |
| Save              |        |        |

## Sensors list import

In Virtual Unit, the list of saved sensors is available as **data\Sensors\sensors.json** file in Virtual Unit's working directory (by default *C:\ProgramData\Virtual Unit*). You can use this file to transfer your sensors list into instruments. Copy the *sensors.json* file into the [VA5\\_DISC](#) root directory. Then, after starting the instrument, the file is automatically imported and the sensors list is used in the instrument.

## Position

The angle of sensor (see picture below). Usually used for proximity sensors.

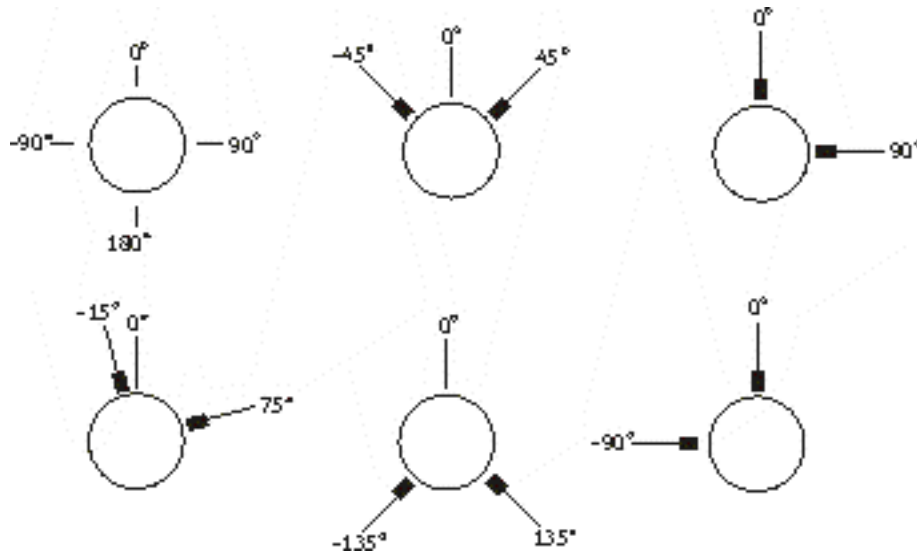

**DC gap channel**

In case of displacement sensor, a DC channel could also be entered, which is used for **gap** measurement (the sensor must be connected to both AC and DC input). The **gap** value is stored in time signal and orbit measurements and the value is added to a signal.

**ISO Machine Group**

You can set the appropriate machine group according to the **ISO 20816** for each channel separately (the **AC1 – AC4** menu) or for all channels together (the **All ISO** menu). The **ISO 20816** group and foundation parameters are used for limit values calculations and green, orange, and red indication.

**ISO Machine Foundation**

**rigid, flexible**  
Only available if ISO machine group is defined.

**Bearing**

The fault bearing frequencies can be displayed in spectra. The bearing definition is required for that. You can set the bearing for each channel separately (the **AC1 – AC4** menu) or for all channels together (the **All Bearings** menu).

**database**  
Select bearing from a database.

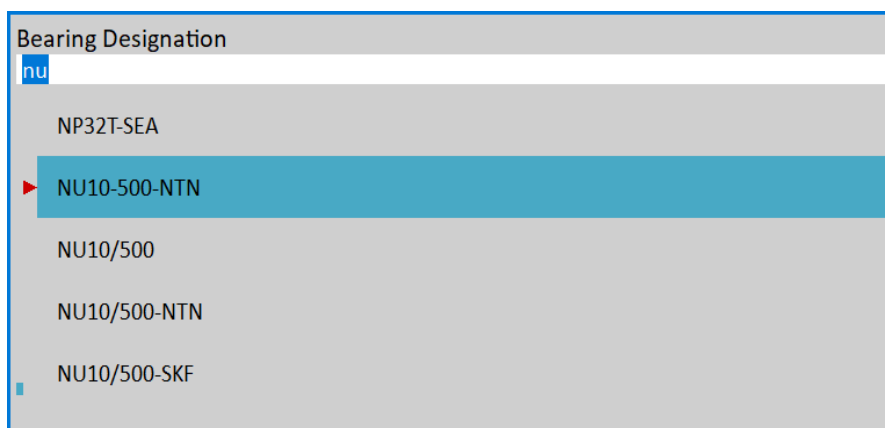

Enter the name (or part of the name) and use the up/down arrows. Confirm by *Enter* or tap the item.

**user**

If the required bearing is not in the database, you can define the parameters manually.

### **undef**

No bearing defined. Fault frequencies will not be displayed.

### ***Rotating Race***

#### **inner, outer**

Only available if a bearing is defined.

You must define which race rotates for the correct bearing fault frequencies calculation.

## **DC Sensors**

DC sensors are used for direct current signals, for example, temperature, pressure,... The DC sensor menu can be opened using the *MENU / Sensors / DC1 – DC4* or *All DC*.

### ***Sensitivity [mV / “unit”]***

**1, 10, 100, user** – Define the sensor's sensitivity value in the sensor's physical unit.

### ***Offset [mV]***

**0, user** – Define the sensor's offset value in miliVolts.

The used formula:

**output value in “unit” = (input value in mV - Offset) / Sensitivity.**

### ***Unit***

Select the unit according to a sensor's type.

### ***Name***

The name of sensor. See [AC Sensors / Name](#) for more details.

### ***Position***

The angle of sensor. See [AC Sensors / Position](#) for more details.

## **Tacho / External Sensors**

A tacho probe or an external trigger source is connected into the TRIG input. The TRIG input signal should contain pulses which can be used for speed calculation or for measurement triggering.

The tacho signal (magenta line), the trig level (grey line) and the created tacho pulse (yellow line) are displayed on the picture.

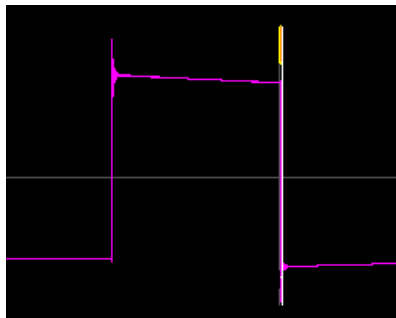



## Trig Level [V]

A correct reference value has to be set. For example, when the standard tacho level is 0.5V and the pulses reach 1.5V, then the value 1V should be correct. The negative pulses are not allowed, you need to use Adash converter for them.

## Trig Edge

**rising, falling** – Edge for triggering.

The trig level together with the trig edge define the time of trigger (the time when the trig or tacho mark is generated).

If the edge is set to **falling**, then the time of trigger comes when the TRIG signal **decreases** from the value higher than trig level to the value lower than the trig level.

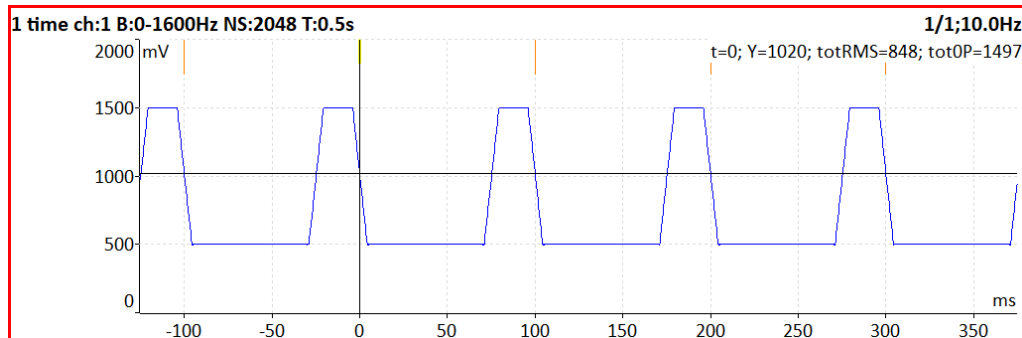

If the edge is set to **rising**, then the time of trigger comes when the TRIG signal **increases** from the value lower than trig level to the value higher than the trig level.

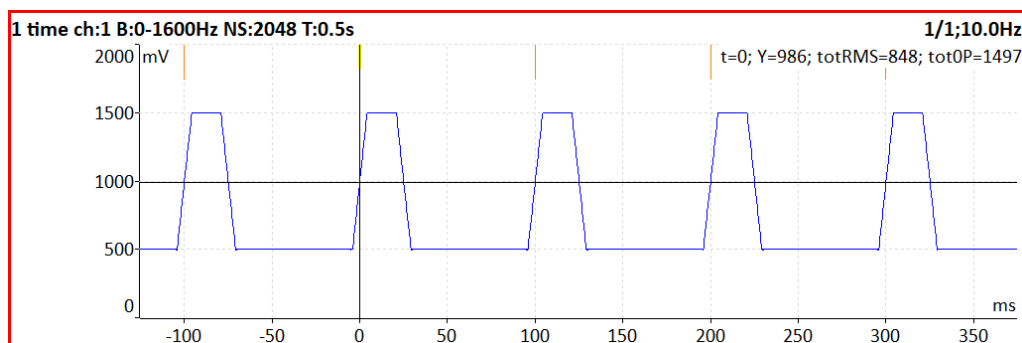

## Pulses per rotation

This value has to be set for the correct speed evaluation when more pulses are generated during one rotation. Non integer values can be also entered. They are used for speed calculation in various stages of gearbox. If *Pulses per rotation* does not equal one, *Trigger Source* cannot be set to **tacho**. Then, the tacho signal is used for speed calculation, but cannot be used for triggering.

## Min Speed

The lowest speed which the user is interested to measure with tacho. A lower speed than this value cannot be recognized. In other words, it means how long the instrument will wait for two tacho pulses (the speed is calculated from the time between two pulses). When the pulses are missing, then the “No Speed” error is displayed. When you choose 1Hz, then the waiting interval is 1 second. When you enter 0.1Hz, then you will wait 10 seconds.

**Attention!** If the shaft speed is lower than *Min Speed*, no tacho marks are generated and no tacho trigger can occur.

**Attention!** By decreasing the value of *Min Speed*, you increase the time needed for tacho probe failure recognition.

## ***Sensor Properties for Records***

When you use the *record* (recorded signal from memory) for analysis, then the sensor properties are defined in the record, because you had to define them before the recording. You can change them for next analysis, but this change is not written to the *record*. The original values are kept in the *record*.

The new values will be used only for analysing.  
Nothing is rewritten in record.

## **MENU / RUN**

This part of main *MENU* is used for running various tasks.

### **Stethoscope**

Runs the [Stethoscope](#) module. This is another option how to run it. The basic option is to run it from main screen.

### **Camera**

Runs the [Camera](#) module. This is another option how to run it. The basic option is to run it from main screen.

### **IR Camera**

Runs the [IR Camera](#) module.

### **Gallery**

Opens the [Gallery](#) module. This is another option how to open it. The basic option is to open it from main screen.

### **Calculator**

Opens a menu to select from various calculators.

**Note!** The *Calculator* item is not available when [Touchscreen / Enable Touchscreen](#) is set to **no**.

| Calculator            |                           |
|-----------------------|---------------------------|
| CALCULATOR            | VIBRATION CALCULATOR      |
| Standard Calculator   | Vibration Units Converter |
| Scientific Calculator | Bearings Calculator       |
| Units Converter       | Belt Frequency Calculator |
|                       | Gearbox Calculator        |

#### **Standard Calculator**

Simple calculator with functions similar to a small handheld calculator.

#### **Scientific Calculator**

Advanced version of the calculator designed to solve more complex mathematical operations.

#### **Units Converter**

Allows you to convert between commonly used units. Select a known unit in the left column, the desired units in the right columns, and enter a value to generate the resulting conversion.

#### **Vibration Units Converter**

Allows you to convert between commonly used vibration units. Enter the speed and known vibration value to generate the resulting conversion.

### ***Bearings Calculator***

Allows you to calculate bearing defect frequencies. Enter the required parameters to generate fault frequencies. You can also enter just bearing designation if is available. We have added new fault frequency named BSF2.

BSF2 = BSF\*2 is the bearing failure frequency which you can see exactly in the spectrum, because a spinning defective ball hits the bearing twice during one ball revolution: once the ball hits the outer ring and once it hits the inner ring.

### ***Belt Frequency Calculator***

Allows you to calculate belt passing frequency. Enter the required parameters to generate belt frequencies.

### ***Gearbox Calculator***

Allows you to calculate shaft speeds and gearmesh frequencies. Enter the required parameters to generate gearmesh frequencies and output speed.

## ***Update***

Update of the instrument firmware. The Update item is available only when the MENU item was selected in the main screen. If any module is running, the Update item is not displayed. You can download the updated firmware from producer website. Follow the procedure:

1. Download the file for update (for example, VA5\_ver0268.up3) and save it to your computer.
2. Connect the instrument to the computer.
3. Run the Explorer or other software, which you use for copy of files.
4. Copy the update file from the computer to the *VA5\_DISC*.
5. Use "*Safely remove hardware*" function and disconnect instrument from the computer.
6. Select the *Update* item.
7. Select the required update file from the list (more version files can be saved in the instrument).
8. The main screen window is closed now. The procedure of update is described in the new command window.
9. After the update the instrument is reset.

## ***Help***

Displays html version of manual

## ***Screenshot***

The screenshot in png format will be saved to the *images* folder on *VA5\_DISC*. You can watch the screenshots in the [Gallery](#).

## ***Export All***

Export all still unexported projects from all modules.

|                             |                     |
|-----------------------------|---------------------|
| <b>Version:</b>             | 0275                |
| <b>Licence:</b>             | 000000              |
| <b>Built:</b>               | 11.01.2021 07:30:00 |
| <b>Installed:</b>           | 11.01.2021 07:32:00 |
| <b>Disc Capacity:</b>       | 57.1GB              |
| <b>Used Space:</b>          | 10.5GB (18.4%)      |
| <b>Free Space:</b>          | 40.6GB (81.6%)      |
| <b>VA5_DISC Free Space:</b> | 95.0%               |
| <b>Battery:</b>             | 98%                 |

**Power Off**

Switch off the instrument.

## Speed detection

You need to know the speed of the measured machine in some cases. Usually, the route readings have the Detected speed set from DDS. We will describe how the speed detection works here.

Detection is done just before the measurement itself after pressing the Start button. There is an information window displayed in the bottom right corner during the detection.

If a tachometer probe is used, then the speed is measured by that.

If tachometer is not used, then a spectrum is displayed. The highest peaks are found and displayed in the list. The highest amplitude speed is on the top of list. You can select the correct value.

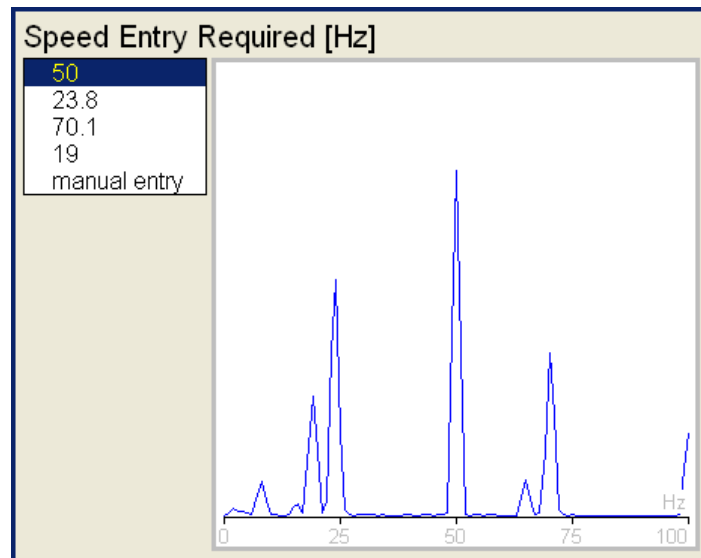

If no value in the list is correct, then select **manual entry** and enter the speed manually. If no value of speed is defined in this window, then the readings will be taken without it.

Enter the speed [Hz]

Speed detection is available only when vibration sensor is used for point reading. In other cases, a warning appears. Then the manual entry of speed is required.

**Speed could not be detected**  
Improper sensor

If the measurement for speed detection fails, then an error message appears. For example, ICP error.

**Speed could not be detected**  
ICP error

If a speed value is detected, it is automatically saved to the data header for following measurement in the same way as the speed value measured by a tachometer probe. If the speed is measured by tachometer probe, the value from the tachometer probe has priority when saving.

# **Analyzer**

The **Analyzer** module is the basic module for signal analysis. If you have not prepared a **Route** measurement, then you use the **Analyzer** for analysis. All required parameters must be set by hand or you can use the saved measurement parameters from memory.

## **Basic concepts**

### **Meas**

The *Meas* means one measurement as it is usually understood, for example, overall value or time signal or spectrum or other.

### **Graph**

We will call the graphical form of that *Meas* values displayed on the screen *Graph*. One Graph works with data from one *Meas* item. You should keep in mind that one overall value is also the *Graph*.

### **Set**

The *Set* is the most important term in the Analyzer mode. The *Set* is a set (or a group) of one or more *Meas* items, which the user wants to collect and display together. For example, you want to take 4 *Meas* together - acceleration overall, velocity overall, velocity time signal, and velocity spectrum. You prepare the *Set*, which includes these 4 required *Meas* items. The definition of *Set* is saved in the Analyzer memory. You can save many various *Sets*, which can contain your often used sets of measurement. Then you select one *Set* and run it. All measurements included in the set are made simultaneously.

### **Reading**

The Reading means all *Meas* items (signals and values) from one set measured together at the same time.

### **Project**

You can use various *sets* for analyzing. But sometimes, you may need more structured items than a simple *set*. We call such items **projects**.

Examples:

1. Meas\_Point\_A  
This is only a simple **Set Project**, which contain several measurements in one point.
2. Pump\_P/ Point\_1, Pump\_P/Point\_2, Pump\_P/Point\_3  
The structured *project* of 3 *sets* (3 points) on one machine (Pump\_P). We call this type of *project* **L1/Set Project**. It means Level1\_Name/ Set\_Names.)
3. Plant\_X/ Pump\_P/ Points  
The structured *project* with name of Plant (Level2), names of machines (Level1) and names of Sets. This Project type we call **L2/L1/Set Project**.

## **Export Project to VA5\_DISC (flash disk)**

A computer can only read data from the VA5\_DISC. All data are saved to an instrument's internal disk during working with a project. Therefore, a project which we want to transfer into a computer must be exported to the VA5\_DISC first. The export to flash is not done automatically because the writing procedure to flash is slow. That is why the user can determine when the right moment to export the set is. VA5 asks user **"Export to VA5\_DISC?"** anytime a project which has been modified is closed.

Export Meas\_Point\_A to VA5\_DISC?

Push **Yes** or **No** according to your needs.

You may also export a project later using **Project/Export** menu item.

### Project List

The first Analyzer screen contains a list of Projects saved in the memory or an empty list when no projects have been saved yet. The time and date of the last saving of a selected project is displayed in top right corner. Each item in the project list has a note on the right side, **S** (means Set), **L1** or **L2**.

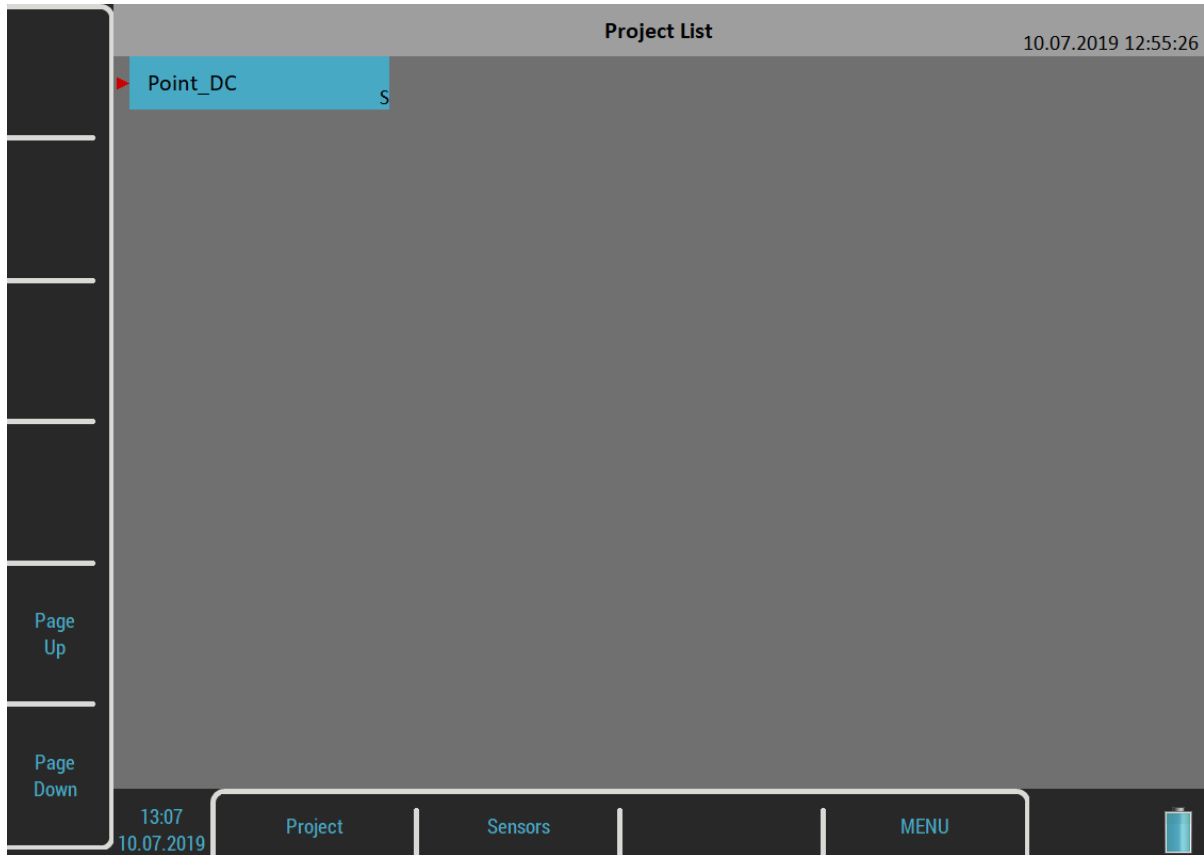

### Project Menu

Push the *Project* button to open the menu.

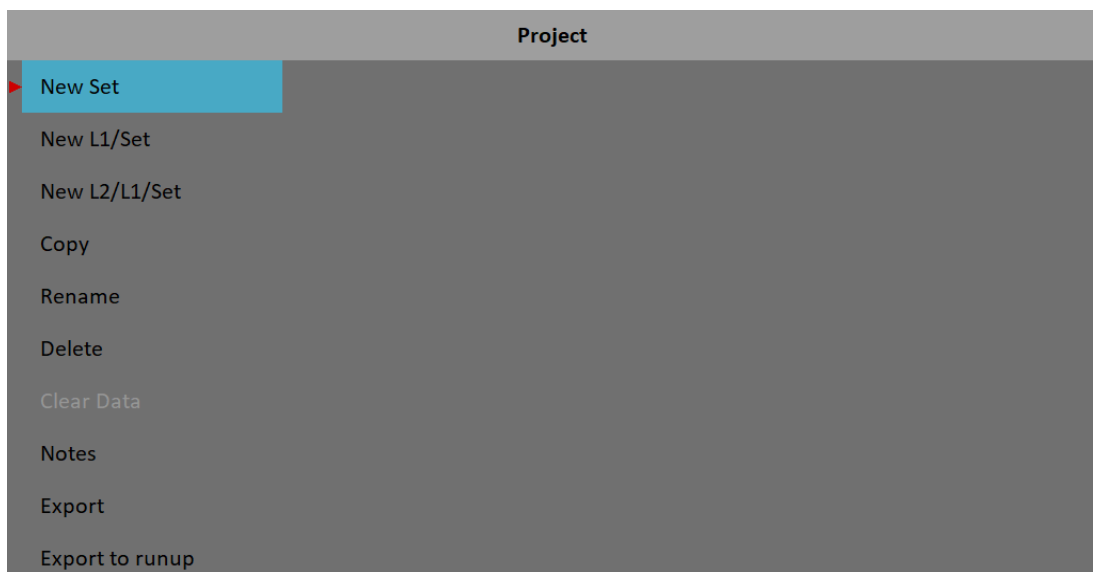

#### New Project - Set creation

Select the **New Set** item from the menu. The “Enter the set name” dialog appears.



|                     |
|---------------------|
| Enter the set name. |
| Meas_Point_A        |

Enter the name of the new set. Your new item appears in the displayed *Project List* (alphabetical order).

| Project List   |   | 10.07.2019 13:09:11 |
|----------------|---|---------------------|
| ▶ Meas_Point_A | S |                     |
| Point_DC       | S |                     |

The **S** letter after the name is the **Set** type indication. Date and time of project last modification (here creation) is displayed in the status bar right corner.

### ***New Project - L1/Set creation***

The *L1/Set* structure usually enables the creation of a machine item with several points. Select the **New L1/Set** item in the menu.

|                    |
|--------------------|
| Enter the L1 name. |
| Pump_P             |

Enter the name on Level 1 (for example, machine name). The *Project List* appears (alphabetical order).

| Project List |    | 10.07.2019 13:10:30 |
|--------------|----|---------------------|
| Meas_Point_A | S  |                     |
| Point_DC     | S  |                     |
| ▶ Pump_P     | L1 |                     |

The **L1** letter after the name is the **Level 1** type indication.

A new item is selected. Open it. The project will be opened and a list of included *Sets* appears (it is empty now).

|          |
|----------|
| Pump_P   |
| Set List |
| Empty    |

Push the *Set* button and select the *New* item.

|                     |
|---------------------|
| Enter the set name. |
| Point1              |

Enter a set name. The *Set List* contains the new *set*.

|          |
|----------|
| Pump_P   |
| Set List |
| ▶ Point1 |

Use the *Escape* button to return back to the project list.

### ***New Project - L2/L1/Set creation***

The *L2/L1/Set* structure usually enables the creation of a plant with several machines. Every machine can contain several points. Select the **New L2/L1/Set** item in the menu.

|                    |
|--------------------|
| Enter the L2 name. |
| Plant_W            |

Enter a name. The *Project List* appears (alphabetical order).

| Project List |    | 10.07.2019 13:12:45 |
|--------------|----|---------------------|
| Meas_Point_A | S  |                     |
| Plant_W      | L2 |                     |
| Point_DC     | S  |                     |
| Pump_P       | L1 |                     |

The **L2** letter after the name is the **Level 2** type indication.  
Open the project.

| Plant_W |
|---------|
| L1 List |
| Empty   |

An empty list of *L1* items appears. Push the *L1* button and select *New*. Enter the name of a new *Level 1* item.

|                    |
|--------------------|
| Enter the L1 name. |
| Fan_X1             |

The *L1 List* appears.

| Plant_W |
|---------|
| L1 List |
| Fan_X1  |

Open the *L1* item and create the *Set* in the same way as in the previous section.

### Copy

Copy the selected item to a new one

### Rename

Rename the selected item

### Delete

Erase the selected item(s). You can also erase more items at once by using the *multi on* function.

### Clear Data

Erase measured data in the selected item(s).

### Notes

You may add notes to the selected item. See the [Route / Notes](#) chapter for more details how to deal with notes.

### Export

Export the selected item to the *VA5\_DISC*, where they are accessible for a computer.

### Export to runup

Export the selected item to a [Runup](#) module. You can also export projects from the Runup module to the Analyzer module (the **Export to analyzer** item is available in the Runup module).

## Graphs Screen

Open a *set project* (noted by *S*) from the *project list* or a *set* from the *set list* of a structured project.

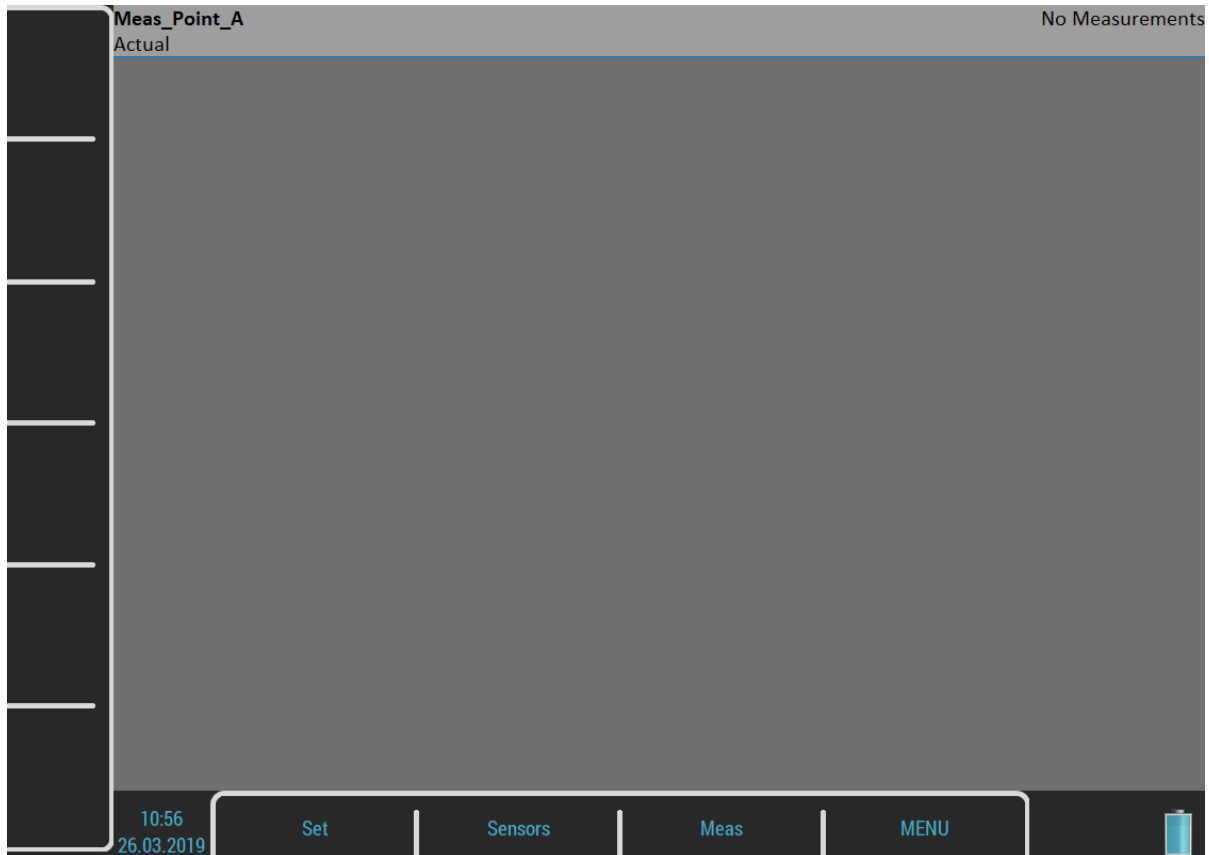

The **graphs screen** contains *graphs* of *set's* measurements (now empty).

The *status bar* contains several texts. The *set's* name (**Meas\_Point\_A**) is in the top left corner. The **Actual** indicator informs you that you are working with actual (currently measured) data. The **Trend/History** alternates the **Actual** if you are watching saved data. **No Measurement** indicates there are no measurements yet. The selected graph index and the total number of graphs is written in this place if some graphs are on screen (e.g., **Graph 2 / 5**).

Two menus are available for the *graphs screen*, the **Set** menu and the **Meas** menu.

## Measurement Definition in the Set

As has been described already, the *set* contains definitions of measurements (*meas*) which we want to take together.

Showing an example is the best way to learn the process of measurement.

The example of requirements for the Set:

Meas 1: RMS overall value in mm/s, frequency band 10-1000Hz, from channel 1

Meas 2: RMS overall value in g, frequency band 500-25600Hz, from channel 1

Meas 3: time signal in mm/s, frequency band 10-1000Hz, from channel 1

Meas 4: Spectrum in mm/s, range 400Hz, 1600 lines, from channel 1, averaging 4

Meas 5: Spectrum in g, range 3200Hz, 3200 lines, from channel 1, averaging 8

You need to define your measurements first. Push the **Meas** button. The **Meas** menu will appear.



Select the **New Advanced** item. An **Edit Measurement** menu will appear.

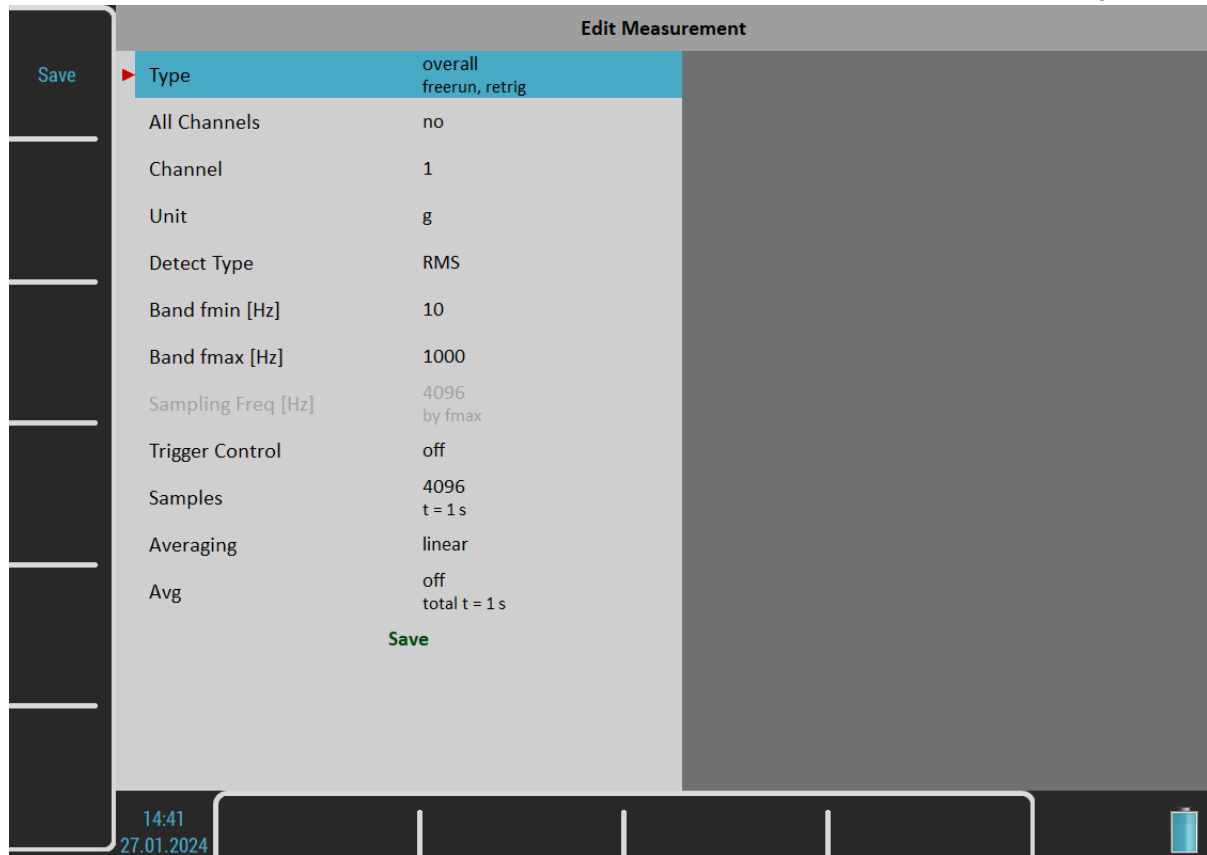

Actual trigger settings are displayed as a note under the **Type** parameter's value.  
If you need to create the same measurement on all channels set **All channels** to **yes**.

**Sampling Freq** is newly separate menu item (it was different in older versions; sampling frequency was determined by parameter Band fmax automatically) and it can be set independently based on your preferences. **Note!** Keep in mind only one exception – for type 'overall' – sampling freq can be set independently only when band fmax value is set to 'none' value. You can see that '**Sampling freq**' option is greyed out in the picture above.

**Older versions:** The **Band fmax** parameter determines a required sampling frequency. Therefore, a *fs* note is displayed under the **Band fmax** value.

The measurement's length depends on the number of samples and the number of values in an average. The time required for taking one average is under the **Samples** value. The total time for all averages is displayed under the **Avg** value.

You can edit the type and parameters of the measurement here. There are factory predefined parameters for ISO RMS which is exactly what we need as our first measurement. Just push the **Save** button and a new graph will be created.

**Note!** There is new button to start the measurement. You can see it in the left top corner in the following picture. You can run the measurement by using this START button. Once the measurement is done, you can use STOP button. It will show exactly in the same position as START button. But only when there is measurement running. You can see this STOP button in the picture later.



Create a second measurement. Use the *Meas / New Advanced* item again. Change the **Unit** to **g**, the **Band fmin** to 500 Hz, the **Band fmax** to 25600 Hz and the **Samples** to 65536. Confirm the dialog and the second measurement will be ready.

The number three measurement is a time signal. Change the **Type** parameter to **time**.

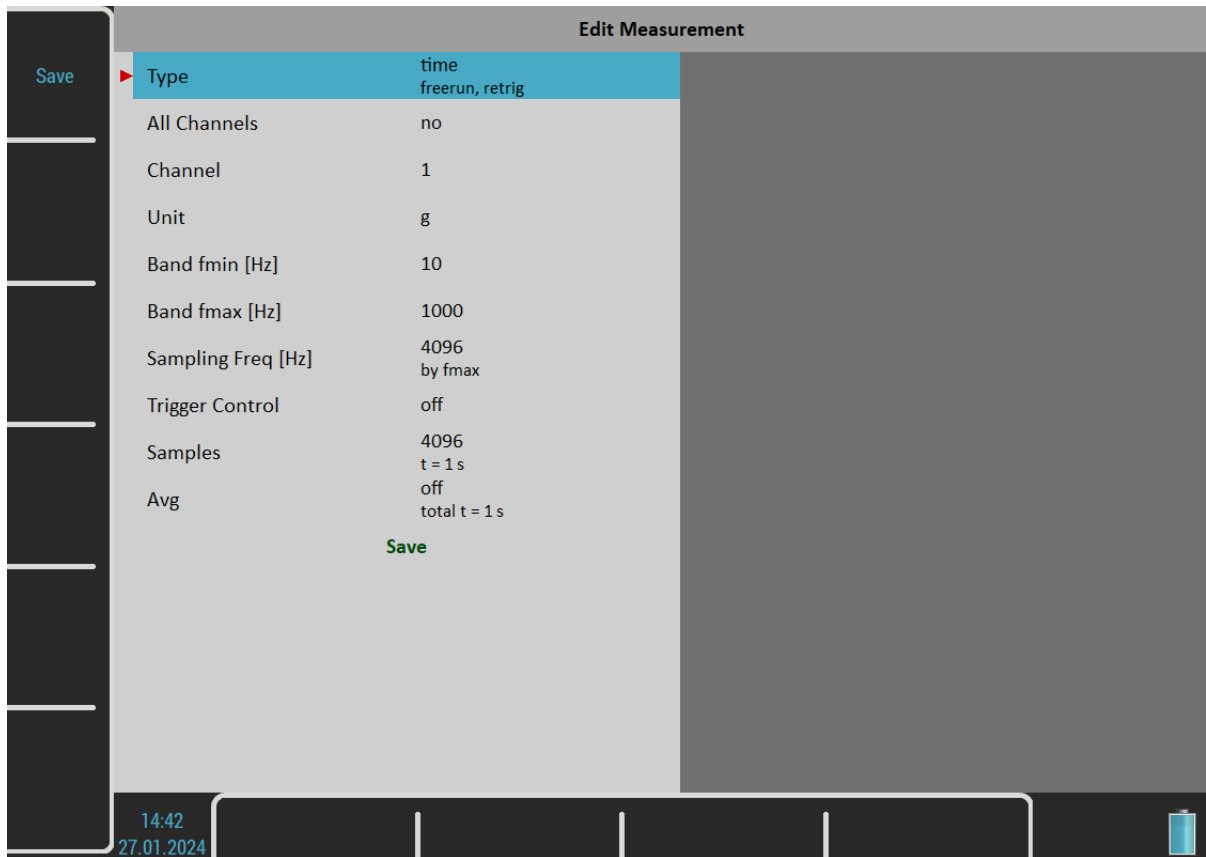

The next two measurements are spectra. The *Edit Measurement* menu for spectrum looks like this.

**Edit Measurement**

|      |                |                                |
|------|----------------|--------------------------------|
| Save | Type           | spectrum<br>freerun, retrigger |
|      | All Channels   | no                             |
|      | Channel        | 1                              |
|      | Window         | hanning                        |
|      | Unit           | g                              |
|      | Zoom Spectrum  | no                             |
|      | Band fmin [Hz] | 10                             |
|      | Range [Hz]     | 1600<br>fs = 4096 Hz           |
|      | Lines          | 1600<br>t = 1 s, df = 1 Hz     |
|      | Averaging      | linear                         |
|      | Avg            | off<br>total t = 1 s           |
|      | Overlap        | 0%                             |
|      | Full Spectrum  | no                             |
|      |                | Save                           |

14:43  
27.01.2024

The *Band fmax* has been changed to **Range**. Change the **Range** parameter to 400 Hz and the **Avg** to 4 and confirm.

To finish the set definition, create another spectrum measurement with the unit of g, range of 3200 Hz, 3200 lines and Avg 8.

The screen contains five graphs of just defined measurements. The graphs don't contain data yet.

Graph 3 / 5

|                     |  |         |
|---------------------|--|---------|
| START               | <b>Meas_Point_A</b><br>Actual                        |         |
|                     | 1 RMS ch:1 B:10-1000Hz NS:4096 T:1s<br>U:mm/s        | No Data |
|                     | 2 RMS ch:1 B:500-25600Hz NS:65536 T:1s<br>U:g        | No Data |
|                     | 3 time ch:1 B:10-1000Hz NS:4096 T:1s<br>U:mm/s       | No Data |
|                     | 4 spectrum ch:1 R:10-400Hz L:1600 T:4s<br>U:mm/s RMS | No Data |
| Control             |  |         |
|                     | 5 spectrum ch:1 R:10-3200Hz L:3200 T:1s<br>U:g RMS   | No Data |
| Graph<br>Max/Min    |  |         |
|                     |  |         |
| Graph<br>Properties |  |         |
|                     |  |         |

10:29  
27.03.2019

Set      Sensors      Meas      MENU

The **Graph 3 / 5** text in the status bar top right corner says that the third graph is selected (you see the red frame) and there are five graphs on the screen. Operations like edit, copy, delete are made on the selected graph. Use the up and down arrow button to change the selected graph.

The description of each graph is at the top. The complete list of symbols is stated in an appendix.

**The description example:**

1 RMS ch:1 B:10-1000Hz NS:4096 T:1s

**The translation:** Meas No.1, RMS value, Channel 1, Applied band filter 10 -1000Hz, Number of Samples of the signal 4096, Time length of signal 1s. The Signal is the time signal from which the evaluation was made.

New buttons are available now, **Control**, **Grah Max/Min**, and **Graph Properties** buttons. Their meaning will be explained later.

When the measurement's definitions are done, everything is ready to start the measurement. Push the **Enter** button.

**Note!** You can see new STOP button in the picture below.

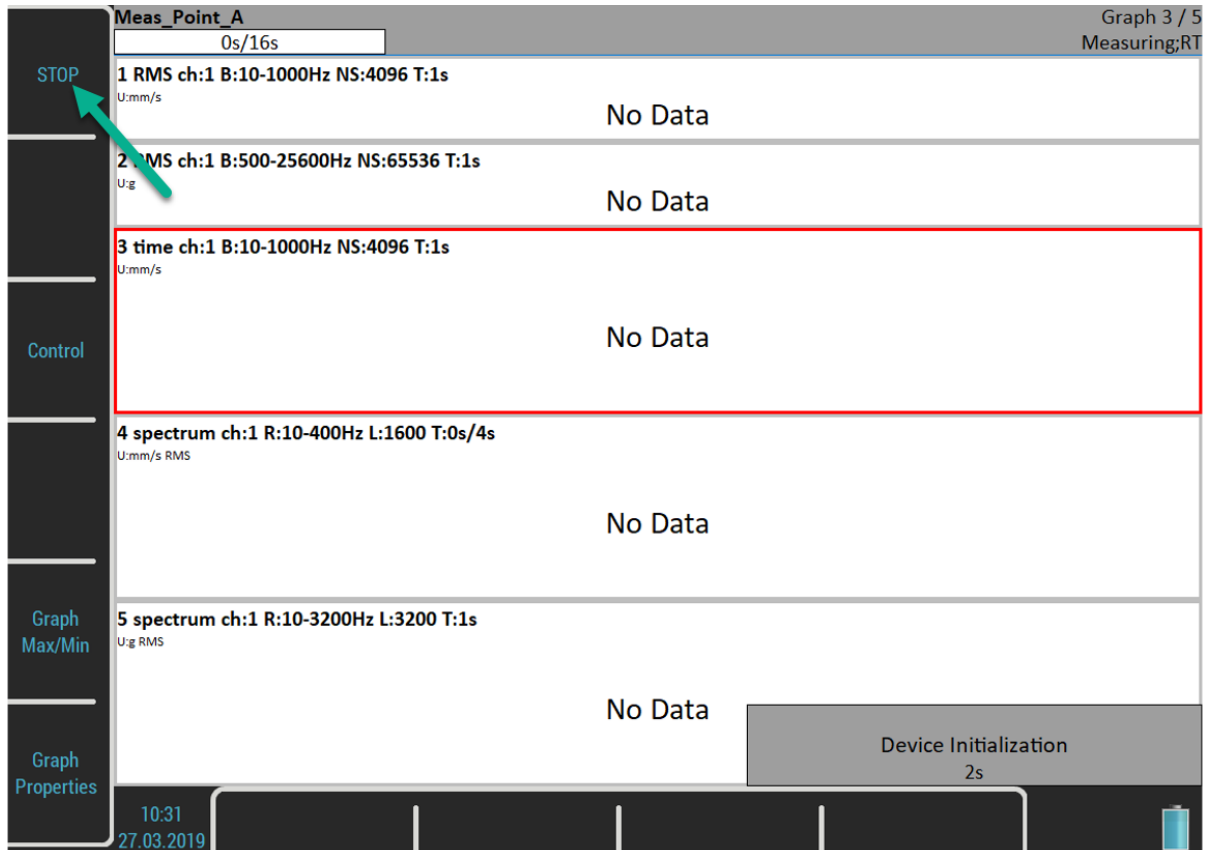

The **Device Initialization** count down appears in the bottom right corner before the measurement begins. The **Measuring** indication is in the bottom right corner of the status bar. The **RT** note means Real Time (see the [Input Buffering](#) chapter). The measurement countdown indicator appears in the top left corner of the status bar if the total time of the longest measurement takes at least four seconds.

**Note!** If the [Analyzer Trigger Mode](#) is set to **single**, then only one reading of each measurement is taken. Then, the measurement process stops.

**Note!** If the [Trigger Source](#) is set to manual, use the **Enter** button to trigger the measurement.

Use the **Stop** button to stop the measurement process. The "**Measurement is not completed**" warning appears when you push the **Stop** button and the measurement is not completed yet in the single mode. Push the **Stop Meas** button to stop it anyway or the **Continue** button otherwise.

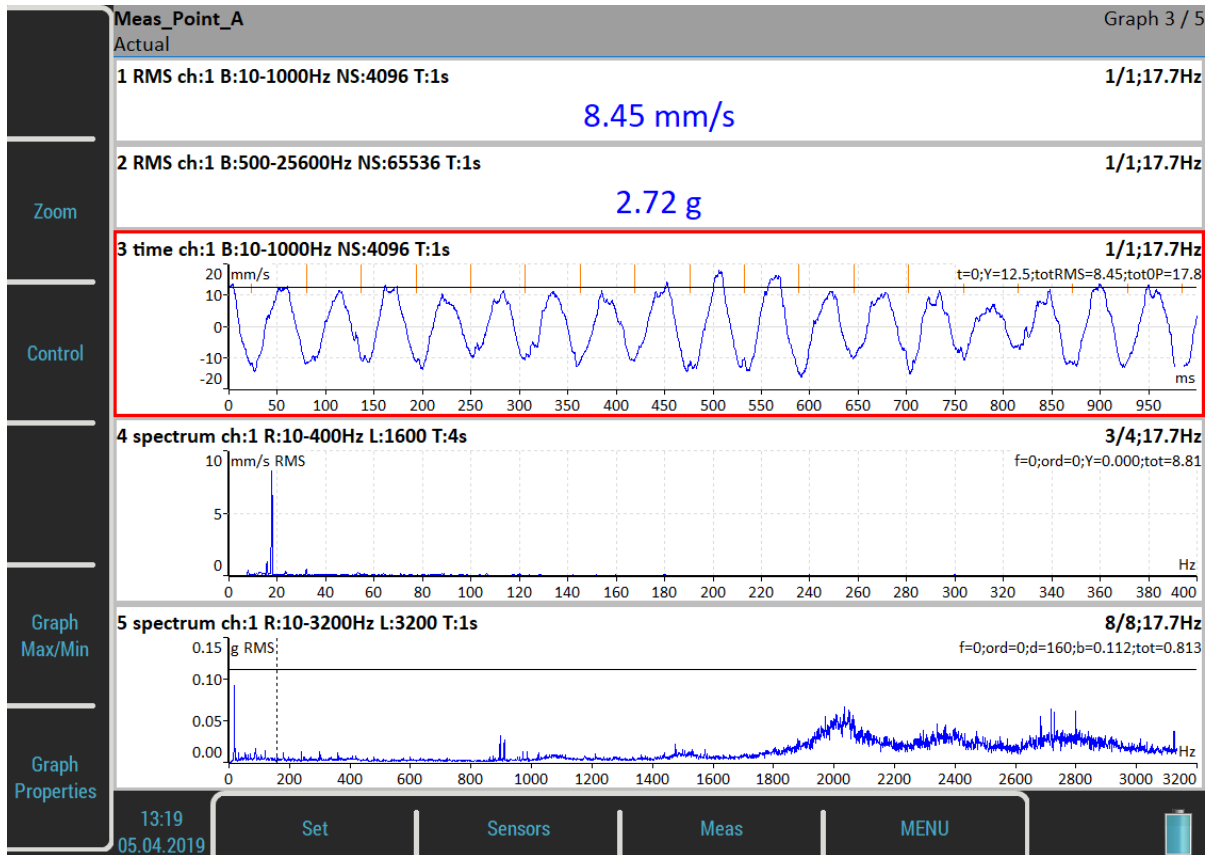

When a graph contains data, the averages and speed notification appear in the graph's top right corner. See the graph 4. The **3/4** means that 3 of 4 averages have been taken and **17.7Hz** is the speed on the beginning of the reading. The light orange lines in the time signal are **tacho marks**.

### Input Buffering

A measured signal is collected into the input memory. The analyzing procedures read the signal data from the memory and compute all required results which are displayed on the screen. In case when too many results are required, the computation is slow and the displayed graphs are not in time - they are delayed. We are talking about **RT** (real time) measurement (you see the current results) or about **non RT** measurement (delayed results).

This information is displayed in the status bar right bottom corner – **Measuring; RT** or **Measuring; non RT**.

After the measurement is stopped, the computation continues until the input memory is empty. The below window appears.

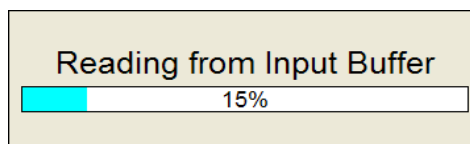

You can wait for all data acquisition. If you are not interested in measurement from input memory, press the **Escape** button to stop data processing.

### Graph Max/Min

The **Graph Max/Min** button maximizes the selected graph to the whole screen or returns back to the screen with more graphs.

### Buttons Modes

Use the up and down arrow button to change the selected graph. Use the left and right button to change the cursor position. You can also do it by tapping the touch screen. If you tap a non-selected graph, it becomes



selected. If you tap the selected graph, the cursor moves to the place you tapped (more precisely, it will move to the nearest place on the signal).

Another control functions are available under the side buttons. Push the **Zoom** button. The buttons mode will change. You will be able to zoom and move in the selected graph. You can zoom in axes – **Zoom X** (zoom in X axe), **Zoom Y** (zoom in Y axe). You can also zoom and move with standard gestures on the touch screen.

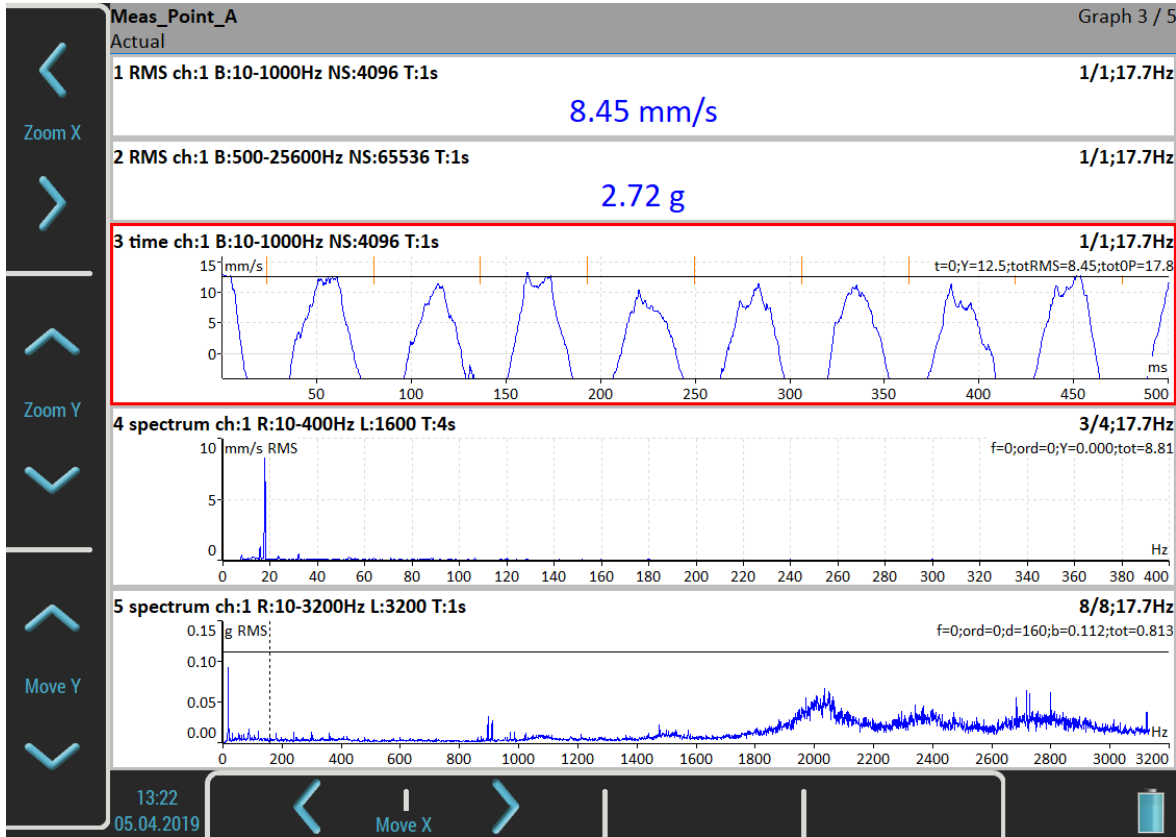

Use the **Backspace** button to restore the side buttons meaning. Then press the **Control** button. You will be able to change the selected graph's **Position**.

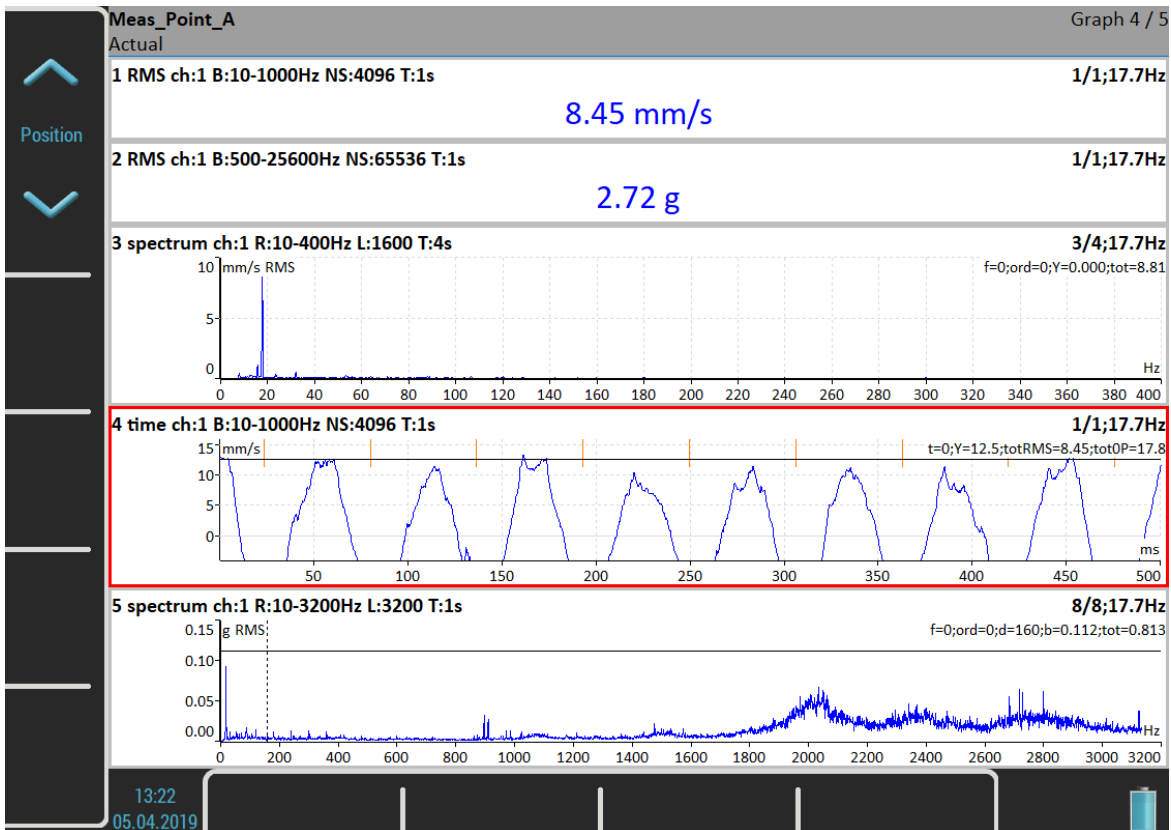

The next available functions of the *Control* mode are **Trend**, **Delta X**, **Zoom Z** and **Move Z**. These functions are hidden now and will be shown in certain situations.

The **Backspace** button restores the side buttons again.

Another possibility of switching the side buttons mode is the **Tab** button. Push the **Tab** button once and the buttons change to the *Zoom* mode. Push it again and the *Control* mode will be active. The next push will restore the initial mode. You can rotate the buttons modes this way. In some situations, there may also be more than two modes. You can use the **Backspace** button anytime to restore the initial mode.

## Set Menu

Push the **Set** button. The menu appears.

### Save data

Save the last measured data. When you close the set without saving, the measured data will be lost. The "Save data?" question appears when you are leaving the set or restarting the measurement without saving.



### Notes

Open the **Notes** dialog for currently opened set. See the [Route / Notes](#) chapter for more details.

### Clear Data

Clear all saved data from the set.

### Enter speed / Cancel speed

Open the **Enter Speed** dialog or cancel currently entered speed. See the [Route / Enter Speed](#) chapter for more details.

### View Trend / View Actual

Use the **Set / View Trend** item to load saved data of the set. The screen which displays the saved data is on the picture. Notice that the overall values are displayed as trends. The status bar contains **Trend/History** notification with the date and time of the beginning of the history. The date and time of the currently displayed value is in the bottom right corner of the status bar. The 4/8 note means that the 4th trend's item of 8 is displayed. You can move the trend cursor by the left and right arrows or by tapping the trend. This is possible only for trends of static values. Graphs like time signals or spectra use the arrows for standard axis x cursor.

The **Control** mode of the side buttons contains a **Trend** function for moving the **trend cursor**. The **trend cursor** is the same for all graphs. Values from the same time are displayed on all graphs.

Use the **Set / View Actual** item or the **Escape** button to view the current values again.

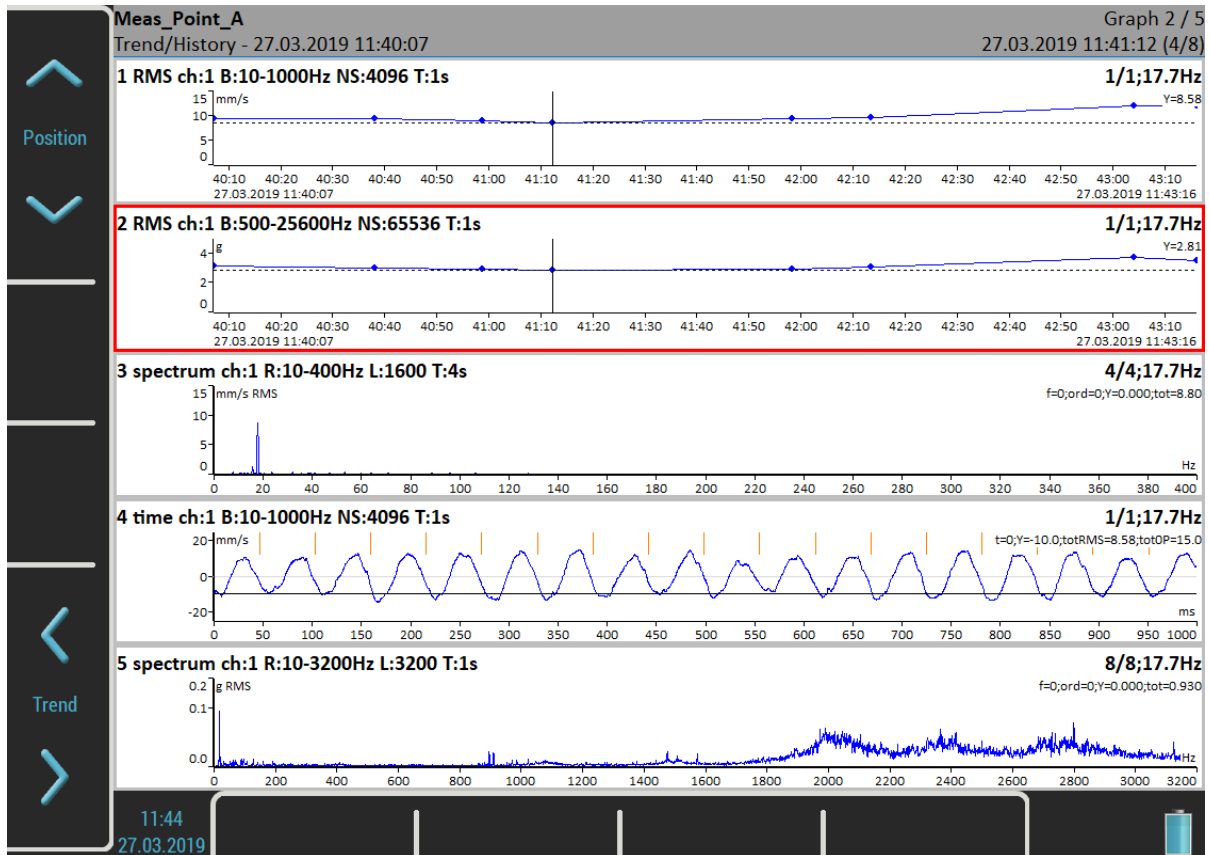

### Clear Last Data

This item is available only when trend is displayed. It deletes the last saved data from the set.

### Meas Menu

Push the **Meas** button. The menu will appear.

### New Basic

When you want to create a measurement from a predefined list, use the **New Basic**. The list of predefined basic measurements appears. Select the required measurement from the list. This way is very fast.

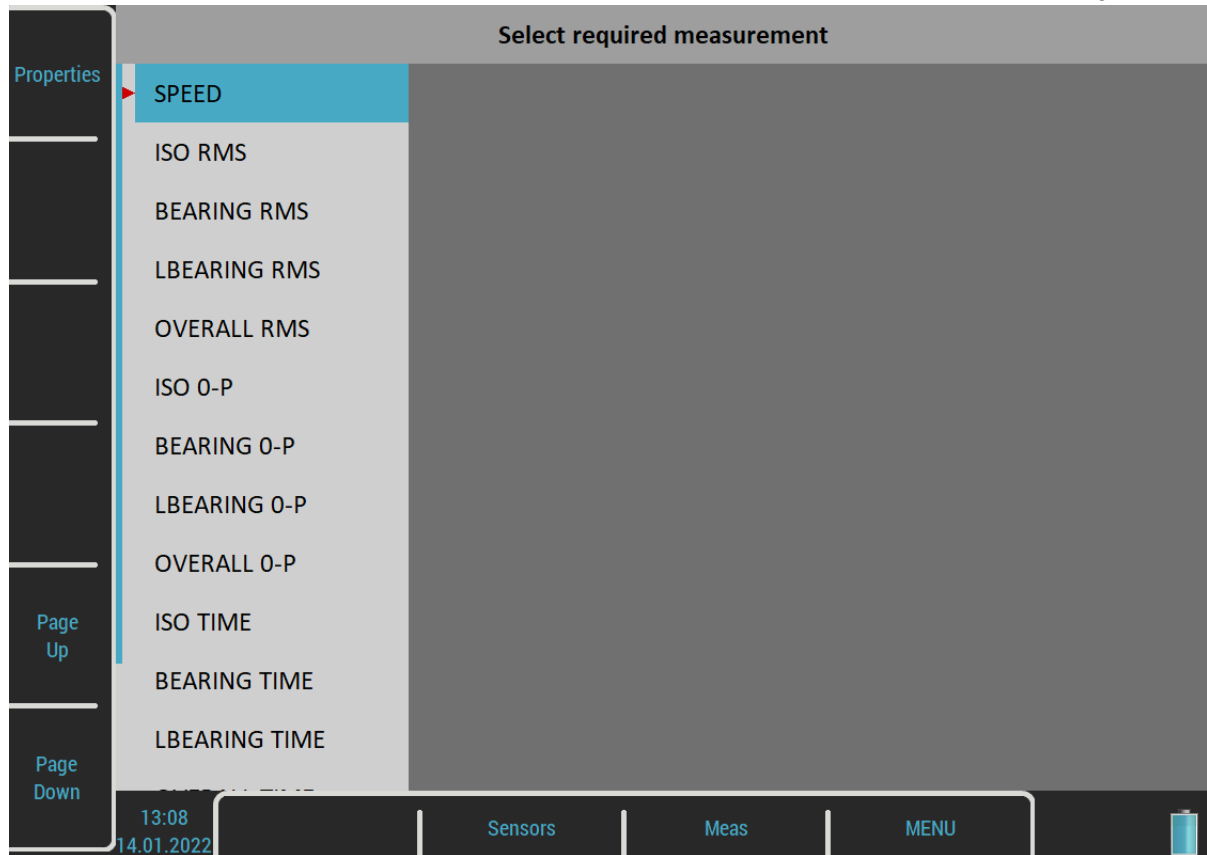

The following table shows parameters of predefined basic measurements.

| Name          | Type         | Unit | Frequency Band/Range | Length  | Samples | Lines | Average |
|---------------|--------------|------|----------------------|---------|---------|-------|---------|
| RPM           | speed        | RPM  |                      |         |         |       |         |
| ISO RMS       | wideband RMS | vel  | 10-1000 Hz           | 1 sec   |         |       |         |
| BEARING RMS   | wideband RMS | acc  | 5000-25600 Hz        | 1 sec   |         |       |         |
| LBEARING RMS  | wideband RMS | acc  | 500-25600 Hz         | 1 sec   |         |       |         |
| OVERALL RMS   | wideband RMS | acc  | 1-25600 Hz           | 1 sec   |         |       |         |
| ISO 0-P       | wideband 0-P | vel  | 10-1000 Hz           | 1 sec   |         |       |         |
| BEARING 0-P   | wideband 0-P | acc  | 5000-25600 Hz        | 1 sec   |         |       |         |
| LBEARING 0-P  | wideband 0-P | acc  | 500-25600 Hz         | 1 sec   |         |       |         |
| OVERALL 0-P   | wideband 0-P | acc  | 1-25600 Hz           | 1 sec   |         |       |         |
| ISO TIME      | time signal  | vel  | 10-1000 Hz           | 1 sec   | 4096    |       |         |
| BEARING TIME  | time signal  | acc  | 5000-25600 Hz        | 0,5 sec | 32768   |       |         |
| LBEARING TIME | time signal  | acc  | 500-25600 Hz         | 0,5 sec | 32768   |       |         |
| OVERALL TIME  | time signal  | acc  | 1-25600 Hz           | 1 sec   | 65536   |       |         |
| ISO SPEC      | spectrum     | vel  | 1600 Hz              | 4 sec   |         | 1600  | 4       |
| OVERALL SPEC  | spectrum     | acc  | 25600 Hz             | 1 sec   |         | 1600  | 16      |

The **Properties** button displays the parameters of the selected basic measurement.

In addition, two more buttons are available in Virtual Unit. The **Insert** button allows you to insert a new measurement to the list and the **Delete** button allows you to delete a measurement from the list. The modified list can be transferred into instrument if you copy the *meas\_templates* file from the *data\VA4template* directory in the Virtual Unit's working directory (by default *C:\ProgramData\Virtual Unit*) into the [VA5\\_DISC](#) root directory. Then, after starting the instrument, the file is automatically imported and the modified basic measurement list is used in the instrument.

### **New Advanced**

Creates a new advanced measurement, where all parameters are available. You can edit type and parameters of the measurement as you need.

## Copy

Creates a new measurement with properties of the selected measurement.

## Info

Displays the selected measurement properties.

## Edit

Enables changing the selected measurement parameters.

## Delete

Deletes the selected measurement.

## Limits

You can define limit values for static measurement types (overall, speed, dc, ...). Limits give a notice to you when a measured value is over some critical value. During the measurement and also during examining the measured values, the appropriate alarm is displayed in the graph of a measurement with defined limits. The alarm informs you about the severity of the measured value.

Each **limit value** divides a numerical axis into two intervals, numbers below the limit value and numbers above it. You can edit the **alarm** for each interval. The alarm represents the severity or color for the values measured in the interval. You can choose one from four severities for the alarm, **Ok** signaled with green color, **Warning** signaled with yellow color, **Alert** signaled with orange color and **Danger** signaled with red color. What severity you assign to which interval is up to you. The particular alarm is displayed when a measured value is in the appropriate interval. You can define more than one limit value and divide the numerical axis into more intervals.

In the example below, we have defined two limit values, 1 and 4 mm/s. We have defined the alarm below 1 mm/s as *Ok* (green color), the alarm between 1 and 4 mm/s as *Warning* (yellow color) and the alarm above 4 mm/s as *Danger* (red color). In the first picture, you can see an actual measured value 2.61 mm/s, which is greater than 1 and less than 4 (displayed as **> 1, < 4 mm/s** on the right side) and thus signaled as yellow color. The second picture shows a trend of values. You can see two limit lines in the trend, a yellow line on 1 mm/s and a red line on 4 mm/s. They represent the defined limit values and their colors correspond to the alarms above the limit. Each value in the trend is drawn as a small colored circle whose color corresponds to the alarm.

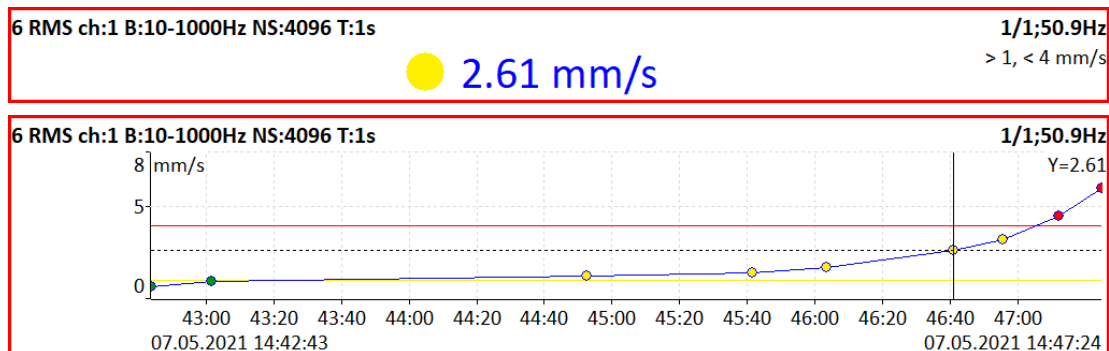

There are 3 ways how to create limits.

### Adash Limits

| Type              | Adash |
|-------------------|-------|
| Limits Multiplier | 1     |
| Save              |       |

The limits are derived from Adash rules, which were developed for many years of Adash history. These limits require knowing the speed value. Adash limits are available for two data cells types:

- velocity readings in the frequency interval 10-1000Hz, which is very well suited for detecting the overall condition of the machine

**Note!** fmin lower than 10 Hz is also accepted, it means Adash limits can also be used for velocity measurements with fmin lower than 10 Hz.

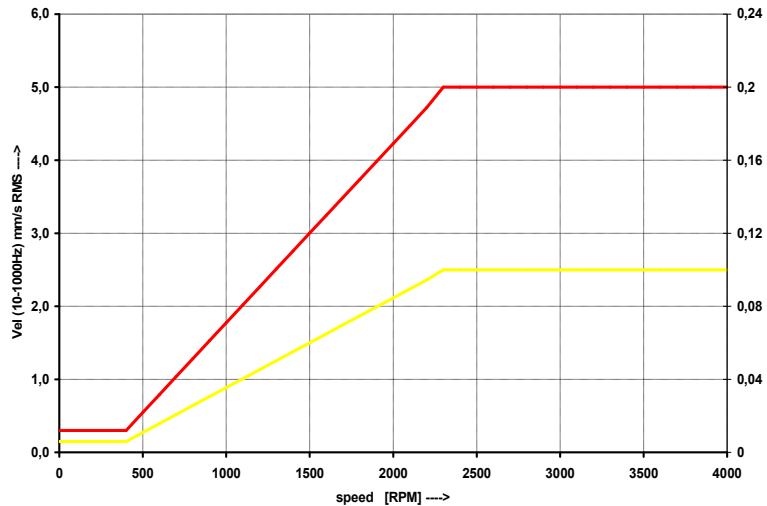

- acceleration readings in the frequency interval 500 - 16 000 Hz, which is very well suited for detecting the bearing condition.

**Note!** fmin higher than 500 Hz and fmax higher than 16000 are also accepted, it means Adash limits can also be used for acceleration measurements with fmin higher than 500 Hz and fmax higher than 16000 Hz.

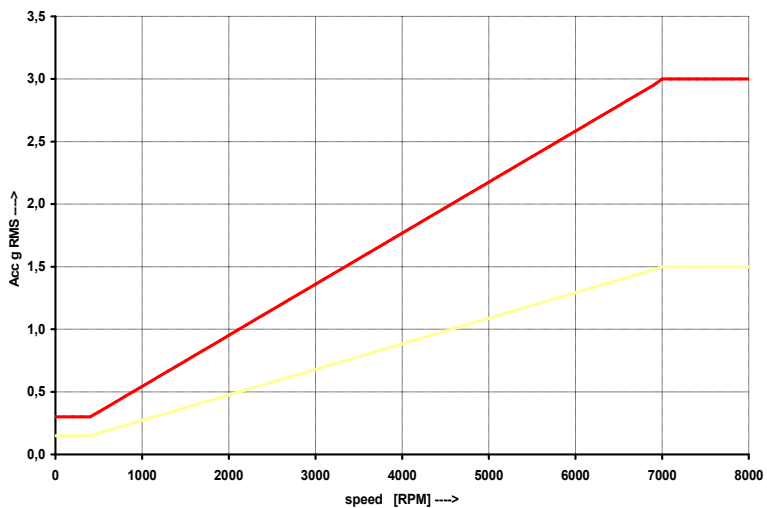

These limit values may be too strict or too little strict for some machines. Therefore, you can adjust them using the Limits Multiplier. Values greater than one increase the limit values and values less than one decrease them. A value of one means the limit remains as shown in the graphs above.

On following figures, you can see the effect of the multiplier. The first graph shows an alarm when the multiplier is set to 1. The second graph shows the same measurement. However, this time the multiplier is set to 2, which means the limit value is twice as high as before. This means the limit is less strict and the alarm level is two times lower. The third case shows the situation with the multiplier set to 0.5.

|  |           |                                |
|--|-----------|--------------------------------|
| 1 RMS ch:1 B:500-25600Hz NS:65536 T:1s | ● 1.000 g | 1/1;50.0Hz<br>> 0.68, < 1.36 g |
|--|-----------|--------------------------------|

|  |           |                        |
|--|-----------|------------------------|
| 1 RMS ch:1 B:500-25600Hz NS:65536 T:1s | ● 1.000 g | 1/1;50.0Hz<br>< 1.36 g |
|--|-----------|------------------------|

|  |           |                        |
|--|-----------|------------------------|
| 1 RMS ch:1 B:500-25600Hz NS:65536 T:1s | ● 1.000 g | 1/1;50.0Hz<br>> 0.68 g |
|--|-----------|------------------------|

**Note!** For Adash limits, only the small colored circles are used in trends, the limit lines are not displayed. It is because of the relation to speed. Each reading may have a different speed and therefore different limits.

The limits are defined according to the **ISO 20816** standard and are available only for velocity readings in the frequency interval 10 – 1000 Hz. The Machine Group and Machine Foundation has to be defined for the appropriate channel before using this standard (see [MENU / SETTINGS / AC Sensors / ISO Machine Group](#) and [ISO Machine Foundation](#)).

**Note!** The severity in ISO limits is also marked by letters A, B, C, or D. Used group and foundation is also displayed in the graph.



**user**

You can define your own limits.

|                 |      |
|-----------------|------|
| Type            | user |
| Unit            | mm/s |
| Alarm 1         | Ok   |
| Add Limit Value |      |
| Save            |      |

By default, there is no limit value defined yet and the Alarm is set to *Ok* for all measured values. It is the same as in DDS dialog for limits.

You can add a limit value by using the **Add Limit Value** item and entering the value (e.g., 1).

|                 |         |
|-----------------|---------|
| Type            | user    |
| Unit            | mm/s    |
| Alarm 1         | Ok      |
| Limit Value 1   | 1       |
| Alarm 2         | Warning |
| Add Limit Value |         |
| Save            |         |

You have now defined one limit value (1 mm/s) which divides a numerical axis into two intervals (below 1 mm/s and above it). You can define an alarm for each interval. Alarm 1 defines the alarm below the Limit Value 1 and Alarm 2 defines the alarm above the Limit Value 1. The same thing can be done in DDS by clicking on the ⊕ symbol and entering the number.

You can add any number of limit values the same way.

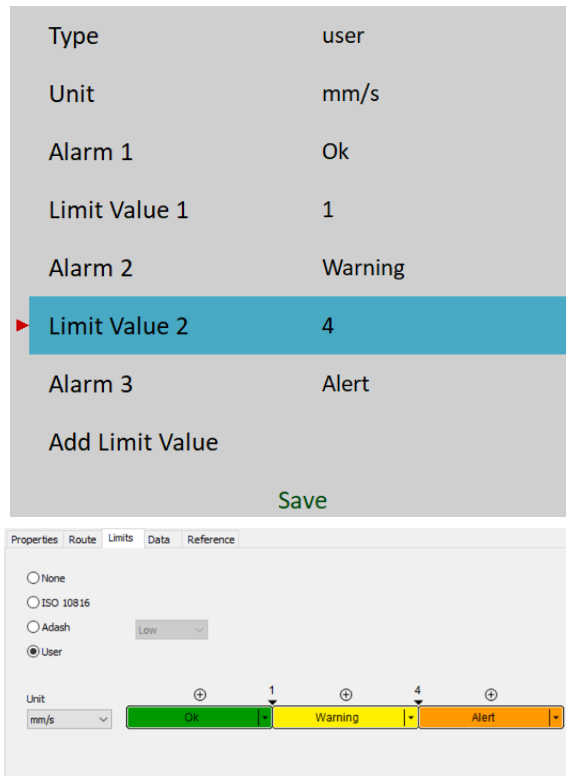

Limit values can also be edited or deleted using the appropriate **Limit Value** item.

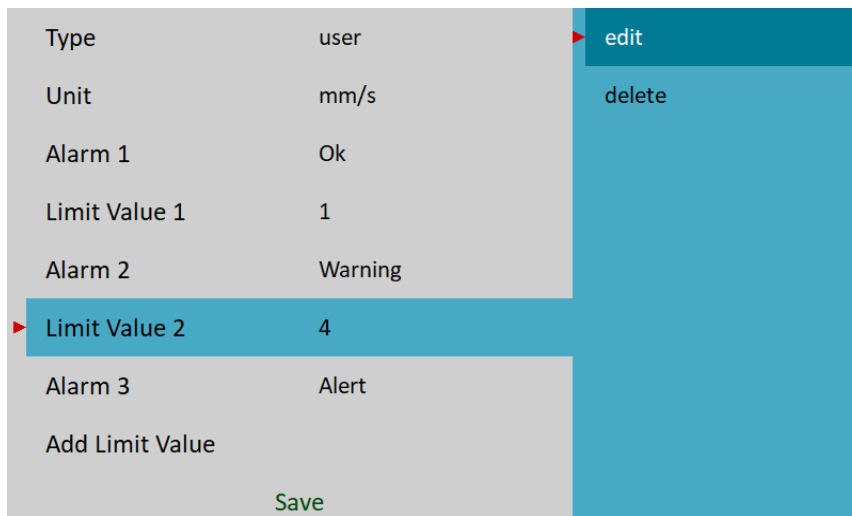

Alarms are defined using the appropriate **Alarm** item.

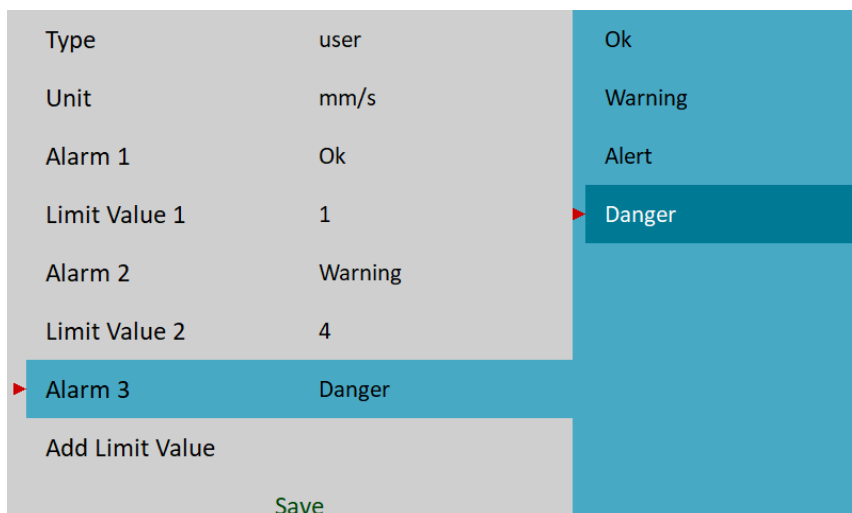



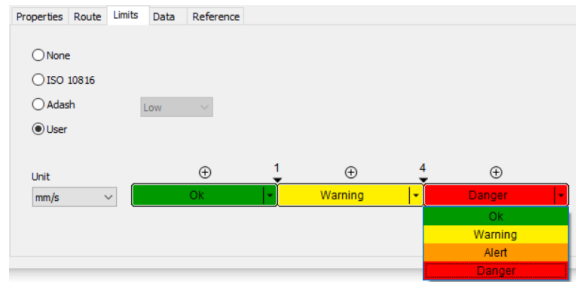

**Note!** You can assign alarms in any order. It's not required for the Ok interval to be the lowest. E.g., for displacement measurements, there is often the Ok interval in the middle and Warning and Alert alarms are assigned to lower and higher intervals.

| Type          | user    |
|---------------|---------|
| Unit          | µm      |
| Alarm 1       | Danger  |
| Limit Value 1 | 50      |
| Alarm 2       | Warning |
| Limit Value 2 | 100     |
| Alarm 3       | Ok      |
| Limit Value 3 | 300     |
| Alarm 4       | Warning |
| Limit Value 4 | 400     |
| Alarm 5       | Danger  |

### Export to uff

Export data of the selected measurement to the **uff** file format (not for all measurement types). The file is saved to the **uff** folder on the **VA5\_DISC**.

If the **Actual** data are displayed, then only this data will be exported. If the **Trend / History** data are displayed ([View Trend / View Actual](#)), then you can export just one displayed data or all data in history. You'll be asked "**Export (All/One)?**".

### Export to wav

Export data of the selected measurement to the **wav** file format (time signal and orbit only). The file is saved to the **wav** folder on the **VA5\_DISC**.

Time signal is exported as one file with two channels (1st channel for signal, 2nd channel for trigger).

Orbit is exported as two files (A and B channel).

Before exporting, you need to enter the required range of the signal in the wav file. It enables you to obtain better resolution in file. If the true peak of the signal is, for example, 8mm/s, then enter 10mm/s.

Enter the wav full scale value [mm/s]

**10**

**Note!** You may choose the 24 bit or 16 bit encoding of the wav file using [MENU / SETTINGS / Global Settings / Wav Encoding](#)

### Export to csv

Exports data of the selected measurement to the **csv** file format. The file is saved to the **csv** folder on the **VA5\_DISC**.

**Csv Header**

The first line in a csv file is a header with the information about the measurement. Parameters in the header begin with a sign and are separated by a semicolon (**sign: value;**). The following is a list of possible signs:

- **u:** unit (the serial number of the unit in which the csv was exported)
- **ch:** channel
- **n:** number of samples (lines)
- **d:** delta (the difference between two samples in x axis unit)
- **eu:** evaluation unit
- **t:** time of the measurement
- **s:** speed during the measurement
- **sensor:** if a sensor's [Name](#) is defined, it is also saved in the csv header
- **note:** The header can also contain a note which is automatically included from the set's notes (see [Notes](#)). Only notes created after the measurement was taken are included.

**Csv Data**

The measurement data are saved in individual lines. Each line contains values depending on the type of measurement.

**Time, g-env Time, ACMT**

time; amplitude; trigger

**Orbit**

time, amplitude A, amplitude B, amplitude X, amplitude Y, trigger

**Spectrum, g-env Spectrum, Octave spectrum**

frequency, amplitude

**Orders, Order spectrum**

order, amplitude, phase

**Frf**

frequency, amplitude, phase, coherence

**Cepstrum**

frequency, amplitude

***Export to csv (all)***

Exports to csv for all measurements which are in the set (to a folder).

***Export to Records***

**Note!** Only when the **record** measurement is selected in analyzer!

The list of all records in the selected record measurement appears. Select one or more records from the list. If you select only one record, then enter a new name. The default name of the new record begins with the set name followed by the date and time of recording (yyyy\_mm\_dd\_hh\_mm\_ss\_msec). The selected records will be exported/copied to the [Recorder](#) module (folder). Now you can work with them in the Recorder module.

***Export to VA5\_DISC***

**Note!** Only when the **record** measurement is selected!

This item is very similar to the previous one. Export the selected records to the *VA5\_DISC VA4recorder* folder.

***Edit Measurement***

The *Edit Measurement* menu is opened using **Meas / Edit**. This menu is also automatically opened when a new measurement is created. The content of the menu depends on the measurement type selection (first row). All parameters of all measurement types will be described here.

***Type***

The type of measurement. Actual [Trigger Settings](#) are displayed below the type value.

**All channels**

You may set this parameter to yes to create the same measurement for all channels.

**Channel**

The input signal source channel for evaluation.

**Channel A**

First channel number for orbits.

**Channel B**

Second channel number for orbits.

**Input channel**

The input channel for the frf measurement.

**Output channel**

The output channel for the frf measurement.

**Unit**

Measurement's physical unit.

The user must first define a sensor's unit according to his sensor. Then, he also defines the measurement's unit which must be convertible from the sensor's unit. That means, it can be any unit of the sensor's physical quantity. For some measurement types, there is also a possible integration or derivation of the signal. E.g., sensor's unit g (acceleration) enables measurement's unit g, m / s<sup>2</sup>, mm / s, in / s, mil, um...

In addition, voltage unit (V, mV) is also accepted as measurement's unit regardless of the value of sensor's unit. In this case, raw input signal is measured without any recalculation to a physical unit.

**Detect Type**

The type of wideband value calculation (P means Peak)

**RMS**

root mean square or effective value

$$\text{RMS} = \sqrt{\frac{1}{n} \sum_i x_i^2}$$

**Scaled 0-P**

$$\text{Scaled 0-P} = 1.414 \cdot \text{RMS}$$

**True 0-P**

it is the true 0-peak value in the waveform, the maximum value of a signal's absolute values

**Scaled P-P**

$$\text{Scaled P-P} = 2 \cdot \text{Scaled 0-P} = 2 \cdot 1.414 \cdot \text{RMS}$$

**True P-P**

it is the true peak-peak value in the waveform (a difference between the highest positive and the highest negative value in a signal)

**AVG**

it is the average value of absolute values of all samples

$$\text{AVG} = \frac{1}{n} \sum_i (|x_i|)$$

**Crest**

it is equal to True 0-P/ RMS

$$\text{Crest} = \frac{\text{True 0-P}}{\text{RMS}}$$

**Kurtosis**

$$\text{Kurtosis} = \frac{\frac{1}{n} \sum_i x_i^4}{\left( \frac{1}{n} \sum_i x_i^2 \right)^2}$$

**Result Type**

Standard frequency response functions measured between the source channel and the response channel

**H1**

input noise,

**H2**

output noise,

**H3**

the average of H1 and H2.

**PAS**

Phase Assigned Spectrum – the amplitude spectrum of response channel and phase are displayed

**Band fmin****none, 1, 2, 10, user**

The low cut-off frequency of a band pass filter, which is applied to the signal before evaluation (removing low frequencies). The **none** value means, that only A/D converter input filter is applied.

**Note!** If you do not expect any important signal below 10Hz, use the 10 Hz filter instead of 1 Hz. The initialization time of the 1Hz filter is much longer than for the 10Hz filter.

**Note!** The **none** value does not indicate the presence of a DC component in the signal measurement. The HP filter on A/D converter is always used. But no additional filter is used. The frequency range with **none** filtering begins at 0.35 Hz (-3dB point). See the response graph.

**Note!** The **none** value is available only for direct measurement without integration. The 1 Hz filter is automatically used if the integration is needed and the none fmin is selected.

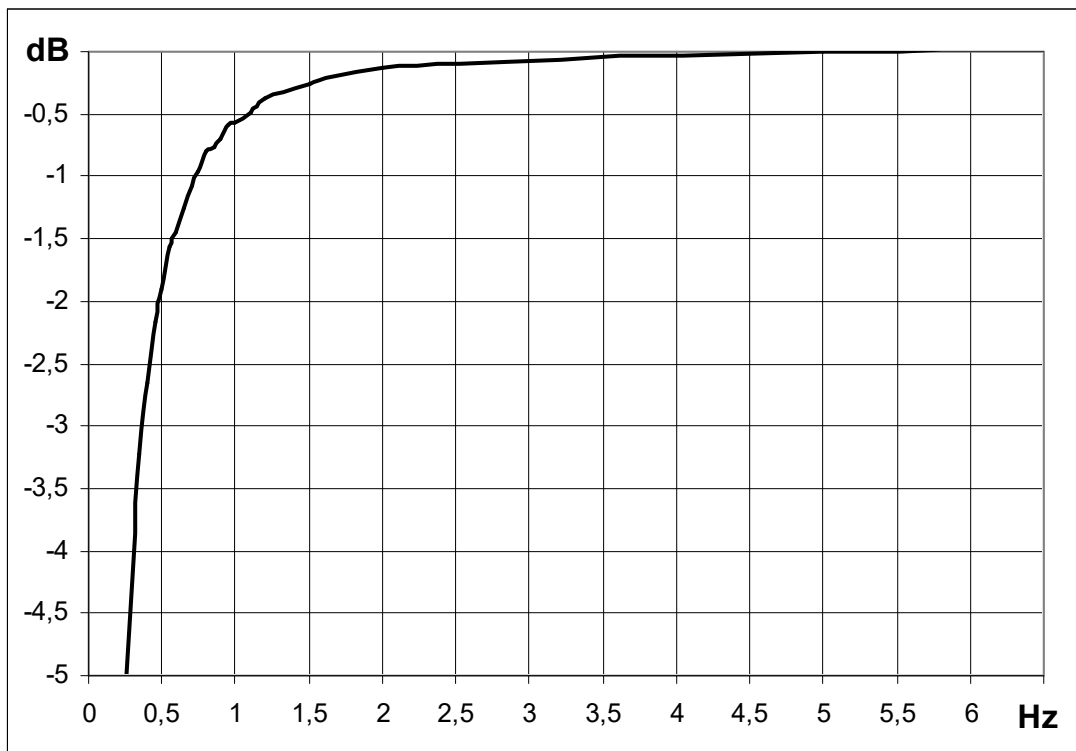

### **Band fmax**

It is the high cut-off frequency of band pass filter, which is applied to the signal before evaluation (removes high frequencies). The **none** value means, that the highest frequency is determined only by input filter of an A/D converter.

### **DEMOD fmin**

The low cut-off frequency of the band pass filter which is applied to the signal before demodulation (removing low frequencies).

### **DEMOD fmax**

The high cut-off frequency of the band pass filter which is applied to the signal before demodulation (removing high frequencies).

The DEMOD fmax is used to determine a sampling frequency.

### **Sampling Freq**

Sampling Freq is newly separate menu item. It was different in older versions; sampling frequency was determined by parameter Band fmax automatically. You could not to set your preferred sampling frequency. Sampling theorem was satisfied by that default setting of sampling frequency based on band fmax value:

$$f_s > 2 * f_{max}$$

Now it can be set independently based on your preferences.

**Note!** Keep in mind only one exception – for type 'overall' – sampling freq can be set independently only when band fmax value is set to '**none**' value. You can see that '**Sampling freq**' option is greyed out in the picture above.

Sampling frequency can only be one of these values:

64, 128, 256, 512, 1024, 2048, 4096, 8192, 16384, 32768, 65536, 196608 Hz

Each value is a power of two, except the last one. The highest value should be used in special cases where you need the highest possible frequency range. However, keep in mind that the fast frequency is not a power of two and as a consequence, you will not get nice values for spectrum resolution or time waveform length because the number of samples of input signal is always a power of two.

However, when you need to use a certain filter, the suggested sampling frequency may not be sufficient. Look at the sine wave with a frequency of 80 Hz. You may set *Band fmax* as 100 Hz which is a suitable lowpass frequency for your signal. If you leave the sampling frequency determined by *fmax*, then its value is estimated as 256 Hz. This means your signal will be sampled with  $256 / 80 = 3.2$  samples per period.

|                   |                |
|-------------------|----------------|
| Band fmin[Hz]     | 10             |
| Band fmax[Hz]     | 100            |
| Sampling Freq[Hz] | 256<br>by fmax |

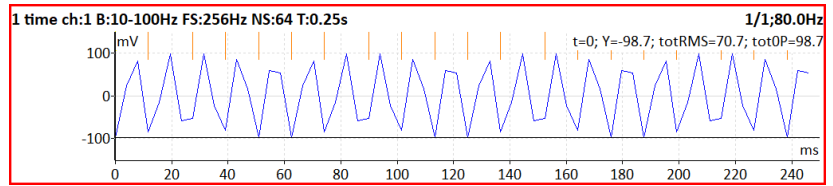

As you can see on the picture, it's hardly recognizable that it is a sine signal. It would be better if you used a higher sampling frequency. And if you still need to use the band filter with the 100 Hz *fmax* frequency, then the *Sampling Freq* parameter enables you to define any higher sampling frequency from the frequencies row and use the so-called **oversampling**. With oversampling, the signal is rendered more precisely.

|                   |                          |
|-------------------|--------------------------|
| Band fmin[Hz]     | 10                       |
| Band fmax[Hz]     | 100                      |
| Sampling Freq[Hz] | 2048<br>oversampling: 8x |

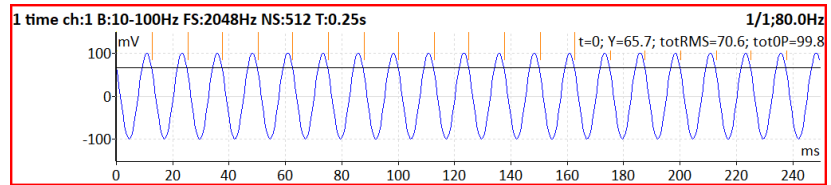

Oversampling is also useful when using filters in orbits. Compare the same orbit with a different sampling frequency.

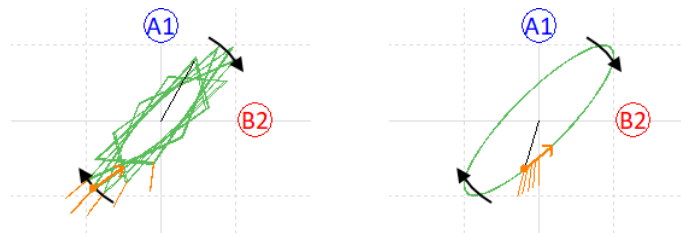

**Warning!** If the sampling frequency value differs from the “by *fmax*” value, the measurement cannot be correctly processed by instruments with a firmware older than 0282.

**Note!** When you set measurement type to overall, keep in mind that **fs** can be defined only for band *fmax* set to ‘none’.

### Sampling

For aps, phase shift

**standard, fast**

Fast: It is used  $fs=196608\text{Hz}$  and the maximum possible speed will increase (but the low speed is also moved higher).

### ACMT Sampling

The sampling frequency for ACMT compression. It defines the sampling frequency of the resulting signal, i.e.,  $1 / \text{ACMT Sampling}$  means time difference between two samples. A lesser value of *ACMT Sampling* means the signal is more compressed.

**Note!** The input sampling frequency is hard coded as 65536 Hz or the maximum possible frequency of input signal, i.e., when a record with lower sampling frequency is used as input, then the record’s sampling frequency is used as *acmt*’s input sampling frequency.

**Note!** *Input Sampling / ACMT Sampling* gives a compression ratio, i.e., the number of samples which are resulting in one sample. With the default value of 1024 you have  $65536 / 1024 = 64$  samples are stored as one value.

### Range

Frequency range of the spectrum measurement. Information about sampling frequency (*fs*) which will be applied for evaluation is also displayed under this item.

Range is used to determine a sampling frequency.

## Window

**rectangular, hanning, transient, exponential, flat top**

The standard offer of FFT windows functions.

When you select the Transient or the Exponential window you need to define its **Shift** and **Length**, both in milliseconds. You can enter these values directly in the menu. But this may be impossible in most cases. A better option is to use the approach from the next example (used to setup an exponential window for a bump test).

Set the **exponential** window. Keep the default values of the **Shift** and **Length** parameters. Confirm the menu. Open the [Graph Properties](#) menu and set the [View](#) parameter to **time** so it shows the measured time signal instead of spectrum. Take the first reading.

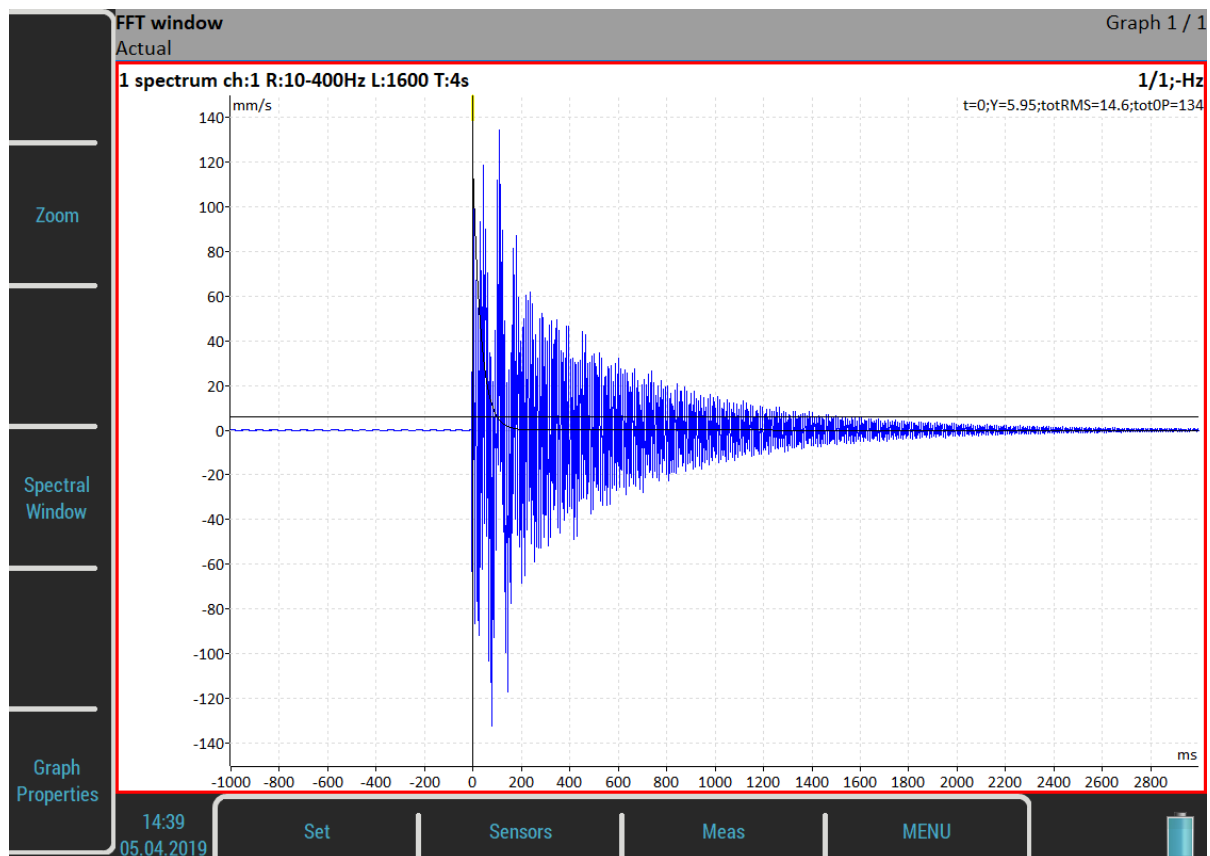

A **Spectral Window** option is available as a buttons mode now. Push the button and you will be able to setup the parameters according to the measured signal using the **Shift1** and **Length1** functions. You may also set these parameters during the measurement process.

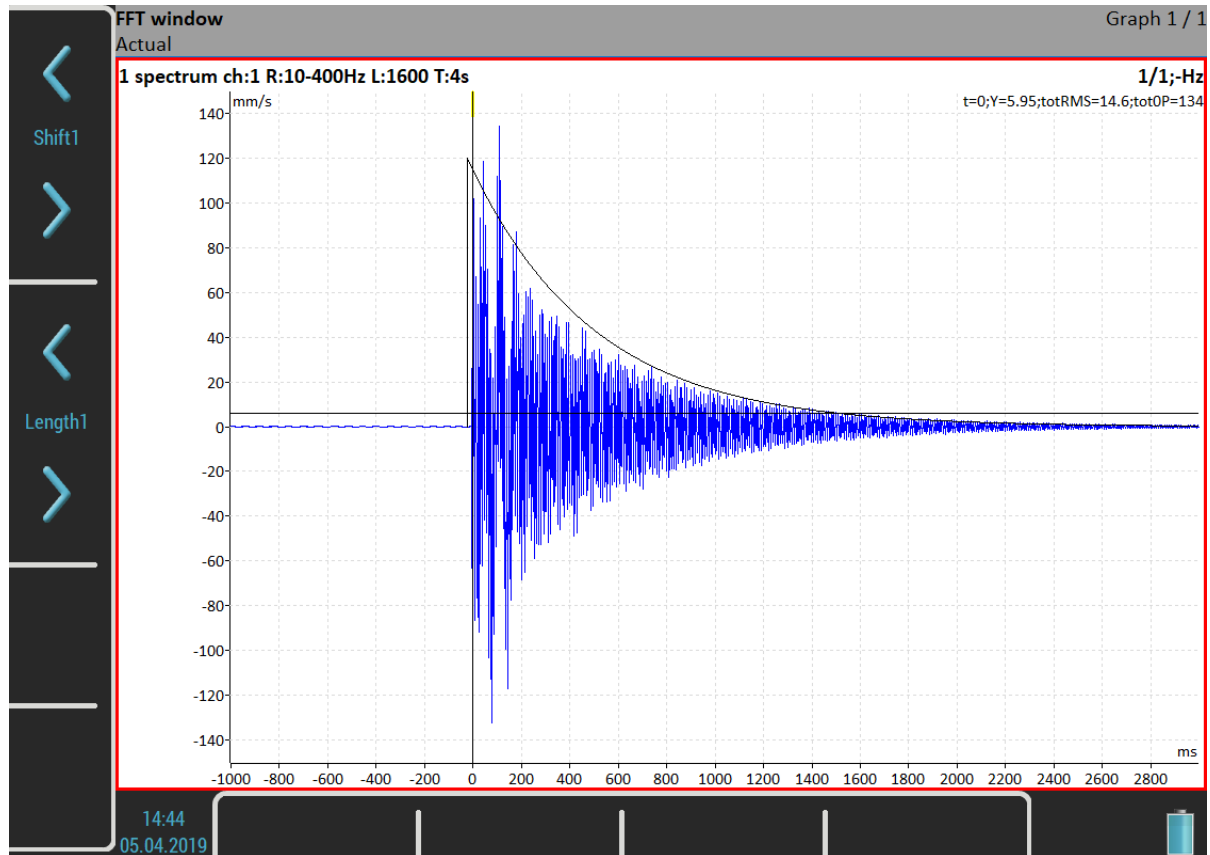

Now, when the window is set, change the view back to the spectrum and take your final reading.

In case of the frequency response function, you must setup two FFT windows for input and output signal. Then a **Shift2**, **Length2** and **Shift12** functions are available moreover.

### **Zoom spectrum**

**no**

standard spectrum will be made (range from zero)

**yes**

zoom spectrum will be made (range around the center frequency)

### **Center freq**

Center frequency for zoom spectrum

### **Trigger control**

**off**

Time signal will contain the defined number of samples

**on**

Time signal will contain the defined number of triggers. E.g., if the [Trigger Source](#) is set to **tacho**, it means the number of revolutions.

### **Samples**

Number of samples. The signal time length is displayed under this item.

### **Number of triggers**

Required number of triggers (when [Trigger control](#) is **on**).



## Lines

Number of lines in spectrum. The signal time length ( $t$ ) and delta frequency between two lines ( $df$ ) are displayed under this item.

## Averaging

**linear**, **peak hold**, **time synchro** (for spectrum)

**linear**, **maximum**, **minimum**, **median** (for static values)

**Note!** Averaging is used to remove variability in time signal and give us information only about values we are interested in. It can be used to filter e.g., noise from the signal we want to analyze further. Noise values are random in the time signal – with averaging these values are basically “inhibited”.

**Peak hold** averaging – it holds the peak value – it can be used to track the minimum and maximum amplitudes in a spectrum over time.

**Time synchro** averaging works in this way: the time signals are averaged (must be controlled by tacho in most cases) and the final spectrum is calculated from the averaged time waveform. It can be set for non-enveloped and non-zoomed spectra.

## Avg

**off** or the number of values in the average value. The total time (*total t*) needed to take the whole measurement is displayed below this value.

**Trigger Source** determines how the measurement between particular values of an average is triggered:

**freerun** when the measurement is started, all signals needed for averaging are taken continuously

**external** when the external trigger comes, all signals needed for averaging are taken continuously without waiting for the next trigger

**tacho** every signal for averaging is triggered by tacho (constant phase)

**amplitude** every signal for averaging is triggered by amplitude

**manual** the first signal for averaging is triggered manually, next signals are taken continuously (freerun)

**manual sequential** every signal for averaging is triggered manually

**Note!** If averaging is used, the **Min** and **Max** values are displayed in the static graph's bottom left corner. This represents the minimum and the maximum value during averaging. You can see the deviation of the measured value. These values are only displayed during measurement and are not saved to the trends.

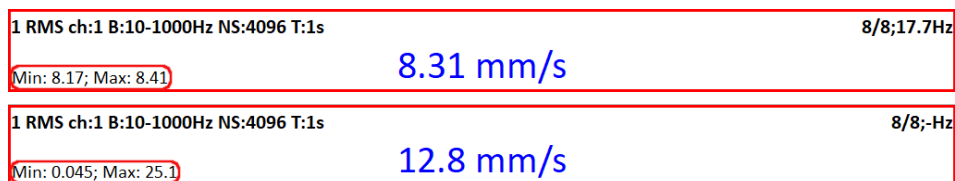

In the first graph, you can see a low deviation in the value (Min: 8.17; Max 8.41). This averaged value is acceptable. On the contrary, the second graph shows a measurement with a huge deviation (Min: 0.045; Max: 25.1). Pay attention to such measurements. The measured value is almost random.

**Note!** If averaging is used, you probably want the measurement to be finished with the number of averaged values as defined. Sometimes, it is not possible to stop the measurement right when the averaging has been finished. Therefore, when you press the **Stop** button during a measurement with unfinished averaging, the measurement process will not stop immediately. Instead, a **Finishing Averaging** info window will appear. You may wait until the averaging is finished or push the **Stop** button again to stop the measurement process regardless of the averaging being finished or not.

Finishing Averaging

## Overlap

Overlapping of signals during averaging in a percentage of signal's length.

**Note!** Overlapping is used to speed-up the averaging. When overlap is used, part of the signal remains and part of it is overlapped with the next one. It means, when we set overlap to 50% and we have time signal with length 1s (two averages – two signals and each of them is 1s long), the final signal will be 1,5s long (not 2s, half of the signal is overlapped as we set this value to 50%).

**Attention!** The overlap is not used for **time synchro** [Averaging](#).

**Attention!** The overlap is used only for [Trigger Source](#) which doesn't wait for trigger between averages, i.e., **freerun, external, manual**.

## Frequency

### speed, user

The frequency value for phase shift measurement can be entered manually (user), or the speed frequency from a tacho probe may be used.

## Order

The user usually needs the measurement of amplitude and phase on speed frequency. You can define any multiplication of speed in Order parameter and measure amplitude and phase on that frequency.

$$\text{measured frequency} = \text{Order} * \text{speed}$$

**Caution!** You may enter any number as an order, but the phase can only be evaluated for integer orders.

## Orders

**1/2,1-5, 1-5, 1/2,1-10, 1-10**

It defines which orders in order analysis will be measured.

## Resolution

### speed / value

This number defines the bandwidth of the spectrum line. When two near frequencies exist and they are contained in one spectrum line, the line shows the sum of both. For example, when we want to get the correct amplitude and phase value on speed frequency, we must ensure that the spectrum speed line bandwidth contains just the speed frequency. If other frequency exists in the speed line, then it causes a disturbance and we get a wrong value. The next important feature of the **speed / N** resolution is that the number N is number of revolutions in the required time signal, from which the spectrum is made.

**Example!** The speed is 25 Hz. The entered resolution is **speed / 4** (it means that the time signal contains 4 revolutions), i.e., 6.25 Hz. The line bandwidth in FFT will be 6.25 Hz. It means the speed line contains all frequencies in the interval (21.875, 28.125). If any disturbing frequency is in that interval, then a higher resolution must be used, for example, **speed / 8**.

**Attention!** When you select a higher resolution (for example, speed / 64 or even speed / 1024), then more revolutions must be taken and you will be waiting for results a longer time. A higher resolution requires a longer time signal for evaluation. We do not recommend always using the maximum value, because you will be waiting for results longer (much longer). Use a high resolution only in cases when your signal contains two close frequencies and you need to separate them.

**Resolution in orders.** The resolution value in order analysis is related to the number of revolutions like the frequency spectrum is related to the number of seconds. Resolution in frequency domain can be expressed as  $\Delta f = 1 / T$ , where T is the number of seconds per FFT record. Similarly, resolution in order analysis can be expressed as  $\Delta \text{ord} = 1 / \text{rev}$ , where rev is the number of revolutions per FFT record. This resolution is defined in orders. If you want to express the order analysis resolution in frequency unit, you need to multiply the resolution in orders by the speed frequency. Therefore, the value of resolution is entered as the fraction of speed frequency and the required number of revolutions is displayed in the note below the resolution value.

|            |            |
|------------|------------|
| Resolution | speed / 4  |
|            | t = 4 revs |

**Attention!** For measurements with adjustable order value, take care to correctly setup suitable resolution according to the demanded order. The order value must be an integer multiple of the resolution in orders, i.e.,

an integer multiply of the 1 / rev. The menu itself helps you meet this condition. Any time you enter the order, the lowest appropriate resolution is automatically set. Then, you may increase the resolution value according to your needs. The resolution submenu always contains suitable values for the actual order. However, you may still enter any user value. The nearest possible order, which will be used in the calculation, is shown as a note if the actual order is not possible for the entered resolution.

For example, when the resolution in Hz = speed/4, then the resolution in orders = 1/4 = 0.25. For example, the available orders are 1.25, 1.5, 1,75 etc.

|            |                                |
|------------|--------------------------------|
| Order      | 1.2<br>nearest possible = 1.25 |
| Resolution | speed / 4<br>t = 4 revs        |

**Attention!** The order value should be at least four times higher than Resolution in orders. The instrument ensures this condition is met regardless of the setup by increasing the number of revolutions.

### Full spectrum

**yes, no**

The spectrum will have two sides, positive and negative (see literature about turbine analysis for more details). It is important to define the correct sequence of channels. It must match the rotation direction. It means, the tacho mark must come to A channel first and then to B channel. The angle must be less than 180 degrees. Otherwise, the positive/negative parts would be transposed.

### Graph Properties

In addition to measurement parameters, you may also set graph properties which influence the way how signals and values are displayed, e.g., axes scale, logarithmic axis and so on.

**Note!** All available properties will be described now. But not all these properties are always displayed. Only values/choices which currently make sense are displayed during your work. For example, the Axis Z (third) axis is only visible in 3D graphs (for example, cascade or spectrograph).

### Display

**value, trend**

Available for overall values in the [Runup](#) module. It enables the instrument to display a trend during a measurement process. When **value** is used, then only the last measured value is displayed (default setting).

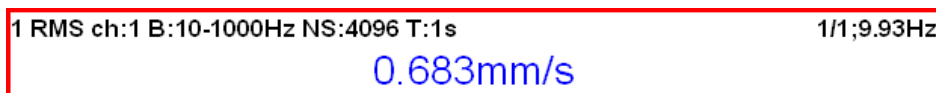

When **trend** is used, all measured values are displayed in the trend.

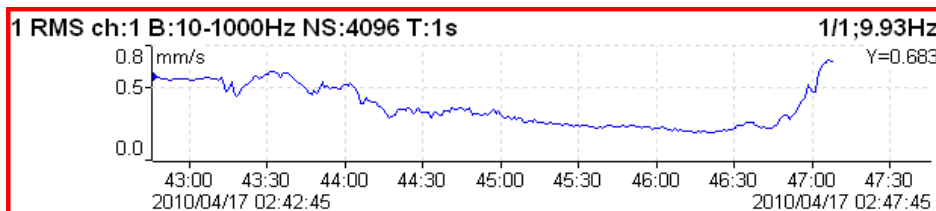

### Scale

- max** Y autoscale for every new signal, but the range is only increasing when a higher value is measured
- next.**
- auto** Y autoscale according to data values of every new signal.
- user** The user defines Y scale for an axis independently of data values.

### **Graph Unit (for spectra)**

Set the physical unit which is used to display a signal in the graph. The unit may differ from the unit in which the signal was measured and stored ([Edit Measurement](#) / [Unit](#)). You can choose any unit from a menu. By default, the **same as meas** value is used, i.e., no recalculation is applied and the signal is displayed in the same unit as it was measured in.

**Note!** Integration and derivation of the signal is available in spectra.

### **Cursor (for time signals)**

|                 |  |
|-----------------|--|
| <b>single</b>   | standard simple cursor                                 |
| <b>periodic</b> | multiplied cursor with several additions of delta time |
| <b>delta</b>    | band cursor with delta time length                     |

When you use periodic or delta cursor you need to setup the **Delta X** value. This can be done in the *Graph Properties* menu or by using **Delta X** function available in the **Control** mode of the side buttons. During initialization, the *Delta X* value is set according to speed if possible.

### **Cursor (for spectra)**

|                 |  |
|-----------------|--|
| <b>single</b>   | standard cursor                        |
| <b>harmonic</b> | cursor with several additions of delta |
| <b>sideband</b> | cursor with one addition of delta      |
| <b>delta</b>    | cursor with one addition of delta      |

When you use sideband or delta cursor you need to setup a **Delta X** value. This can be done in the *Graph Properties* menu or by using **Delta X** function available in the **Control** mode of the side buttons. During initialization, the *Delta X* value is set according to speed if possible.

### **Cursor Position**

Time or frequency position of the cursor in the selected graph.

### **Delta X**

Time or frequency interval used for delta cursor computation.

### **Axe X**

lin, log

### **Axe Y**

lin, log, dB

### **Axe Z**

|                |  |
|----------------|--|
| <b>time</b>    | Signals are ordered according to a reading's time.   |
| <b>speed</b>   | Signals are ordered according to a reading's speed.  |
| <b>regular</b> | Signals are ordered according to a reading's time but drawn with constant space between two readings regardless of when the readings were taken. |

### **Order Z**

**first in front, last in front**

The order of spectra on Z axis.

### **Detect Type**

**RMS, 0-P, P-P**

Detect type for spectral amplitude values. P is for peak.

**Note!** This value is the same as the global value defined in [MENU / SETTINGS / Spectrum Settings / Detect Type](#) until you change it here. That means, if you change the global value, it will also be changed here. This will stop after the first time you enter a value here.

**Peaks List**

**on, off**

The 5 highest spectrum lines table.

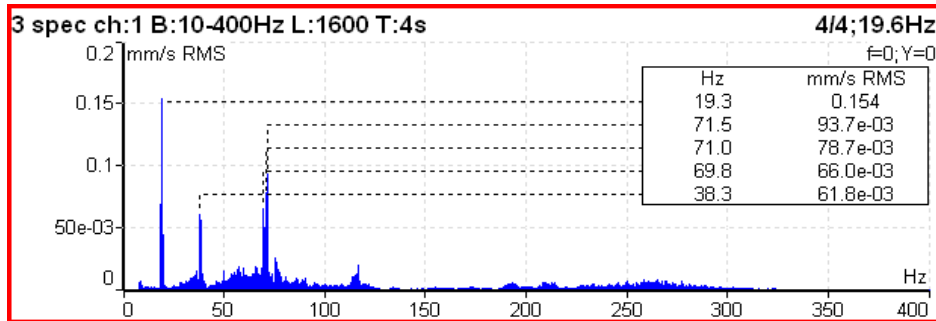

**Synch Table**

**on, off**

Table of values synchronized with speed and line frequency.

- SubSynch** value below speed frequency
- Synch** value on speed frequency and harmonics
- NonSynch** total value without SubSynch and Synch
- Elect** value on line frequency and harmonics (setting in [Global Settings / Power/Line Frequency](#))

All values are in displayed a spectrum unit and in % of total value.

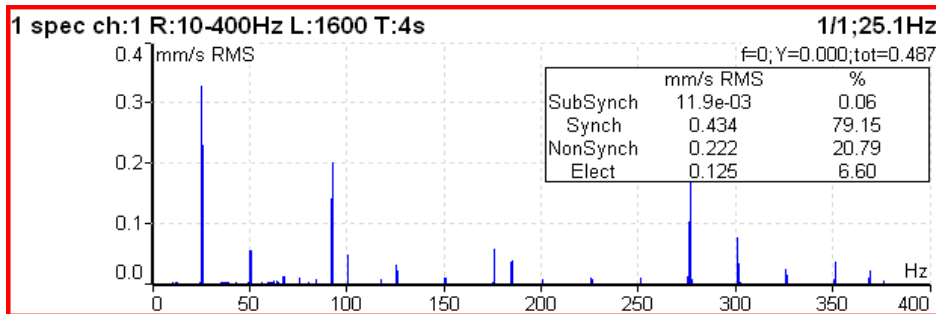

**Orders Table**

**on, off**

Table of values for particular orders in order analysis.

**Statistics Table**

The basic statistic values of trend are displayed:

- n** number of measurements in trend
- EX** means value (arithmetic average)
- $\sigma$  (sigma)** deviation average
- Xmax** maximum value
- Xmin** minimum value
- Xmax-Xmin** the interval of measured values

**Primary Cursor**

When [Global Settings / Cursor Type](#) is set to **max**, you may choose to which signal will the max searching be applied to.

amplitude, phase for frf  
X, Y for orbit

**View (for center line trend)**

center line Standard 2D center line view in the xy plane.  
**AB** Two trends of values measured on A and B inputs.  
**XY** Two trends of values transferred to X and Y

**View (for frf)**

ampl, phase  
real, imag  
nyquist  
amplitude  
phase  
coherence  
time  
amplitudes

**View (for amp+phase trend and complex Smax)**

aps\_t  
Trends of amplitude, phase and speed related to time of reading.

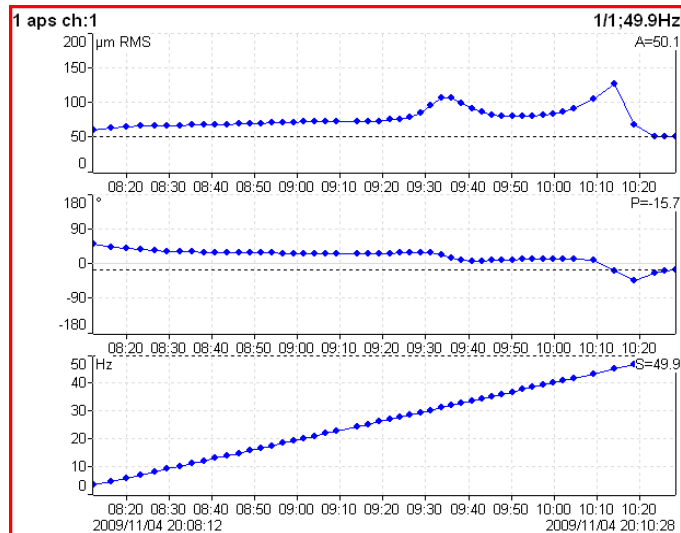

ap\_s  
Trends of amplitude and phase related to speed.

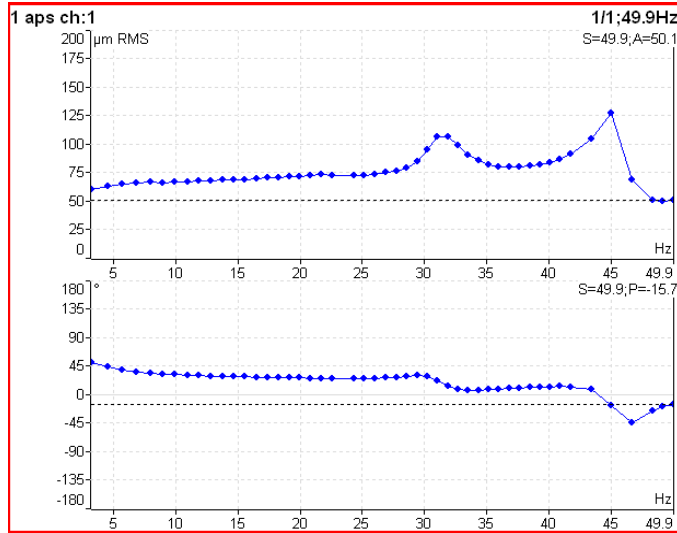

**ad\_s**

Trends of amplitude (upper graph) and **difference amplitude** (lower graph) related to speed. The difference is related to the *trend cursor* position, thus it is always zero in the cursor position.

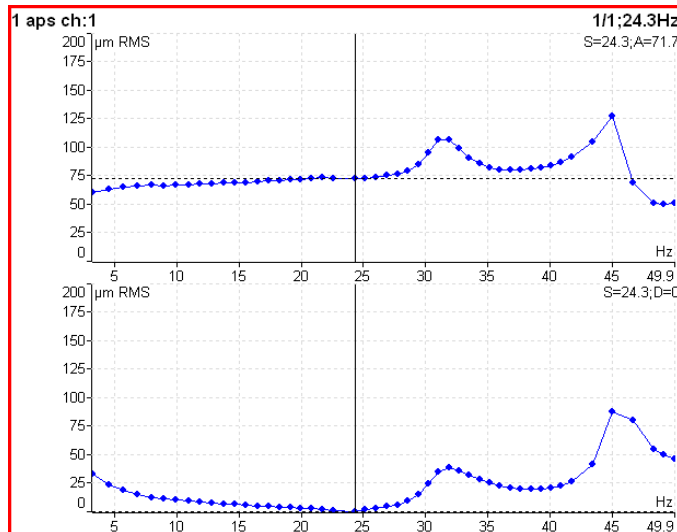

**polar**

2D complex view

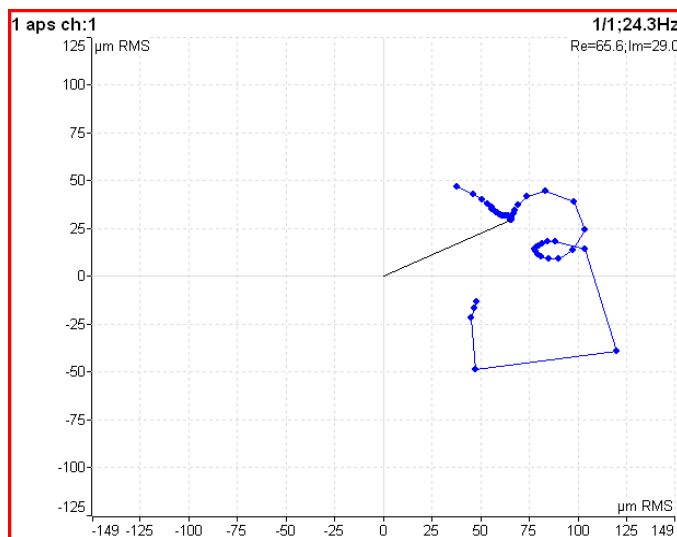

**trend3D\_t**

The 3D "tube" view. It is the Nyquist graph expanded to z axis (time scale).

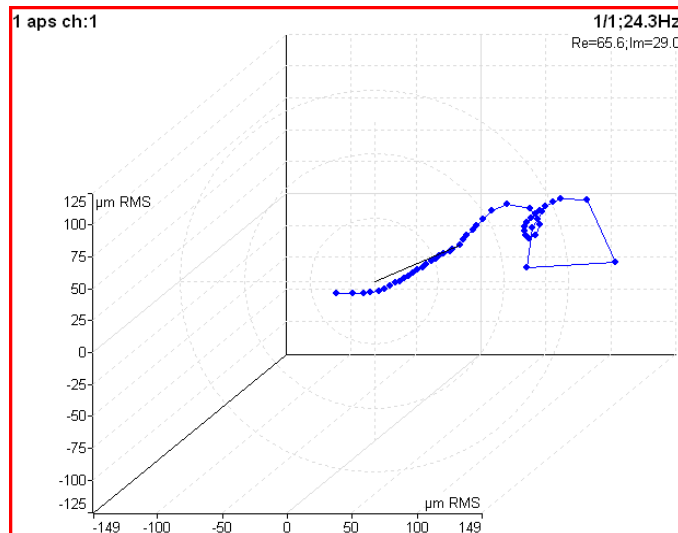

**View (for phase shift trend)**

- linear** Trend of phase shift, amplitude ratio, and coherence related to time scale.
- polar** Polar plot of phase shift and amplitude ratio.

**View (for spectrum trend)**

- amplitude**  
One amplitude graph.
- cascade**  
Cascade graph.
- spectrograph**  
2D view of amplitudes vs. time
- phase**  
One spectrum phase graph

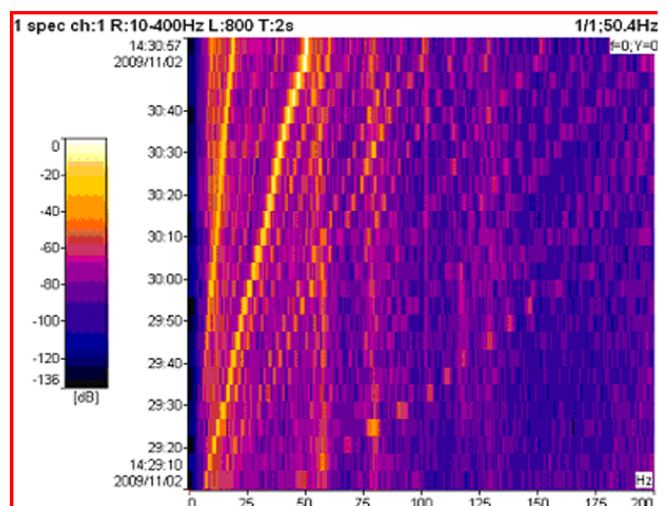
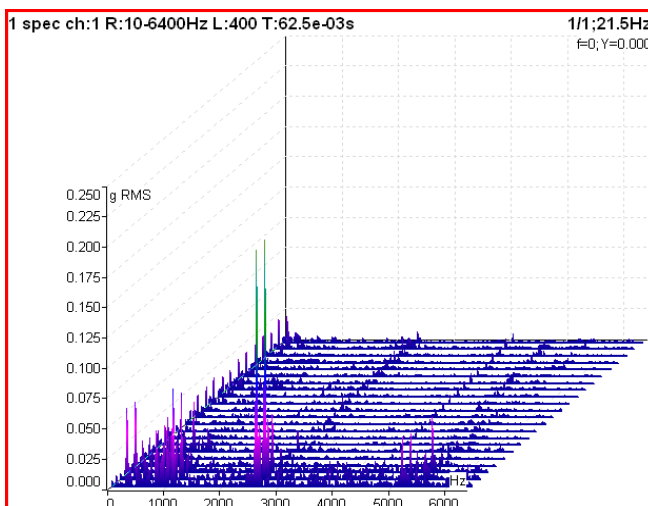

**View (for actual spectrum)**

- amplitude**  
One amplitude graph.
- time**  
Displays the time signal from which a FFT was developed.



**phase**

One phase graph.

**View (for time waveform)**

**linear**

Standard drawing of time signal.

**circular**

Circular drawing

**Note!** When the signal contains tacho pulses, one rotation length is 360° (one circle). If not, then a complete signal is drawn in only one circle.

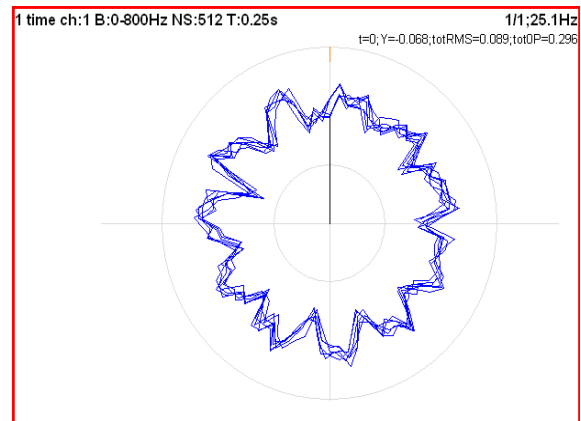
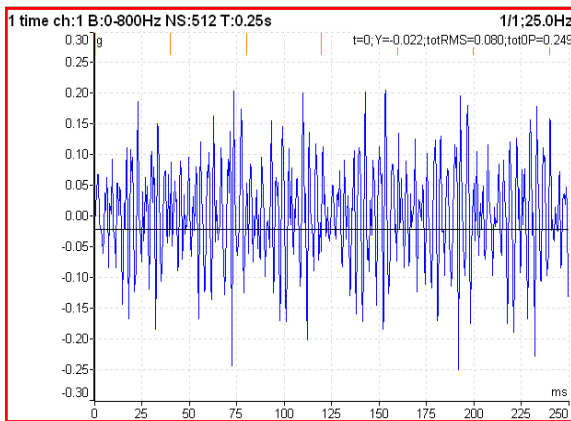

**View (for orbit)**

**orbit**

Standard 2D orbit view in xy plane.

**AB**

Two input time signals from channels A and B.

**XY**

Two time signals transferred to X and Y axes.

**View (for filtered orbit)**

**orbit, orders**

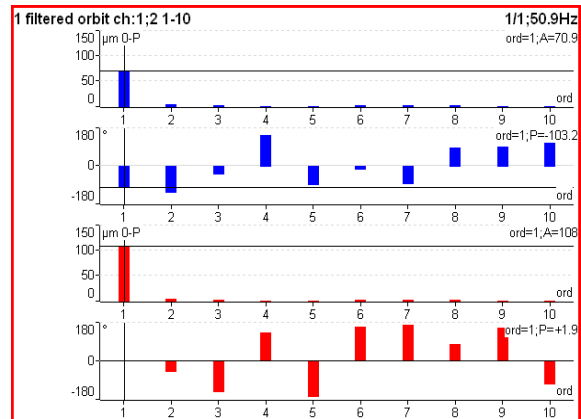
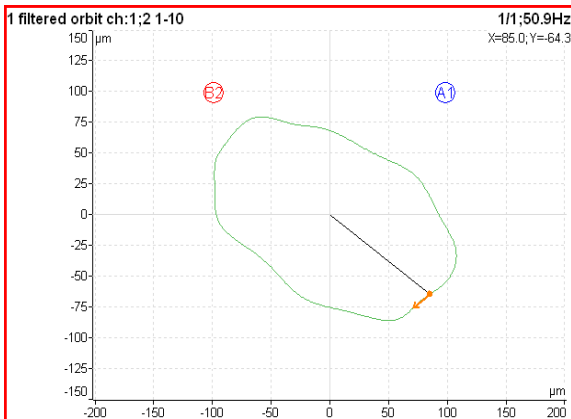

**Time Axe Unit**

**time unit, degrees**

By default, the time axis is marked with time units (milliseconds or seconds). However, you can set the time axis unit as degrees to determine the angle. The angle between two tachometer marks is supposed to be 360°. According to [Angles Counting](#) setup, degrees are negative (for with rotation) or positive (for against rotation). This corresponds to the amp+phase measurement (the phase is negative when the signal maximum is behind the tachometer mark and with rotation is set as Angles Counting).

Time Axis Unit = time unit:

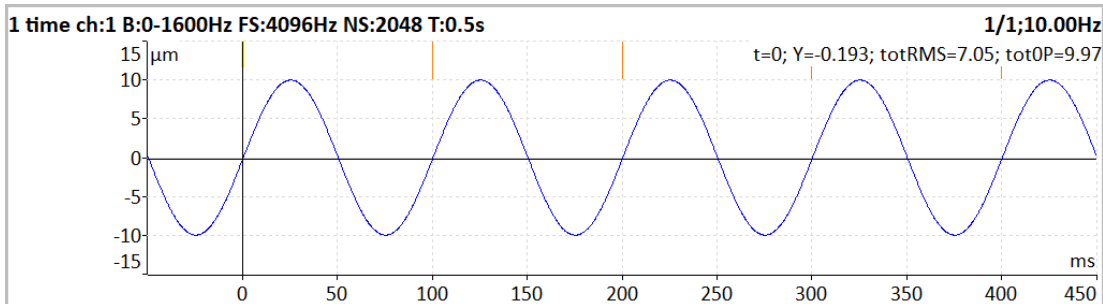

Time Axis Unit = degrees, Angles Counting = with rotation:

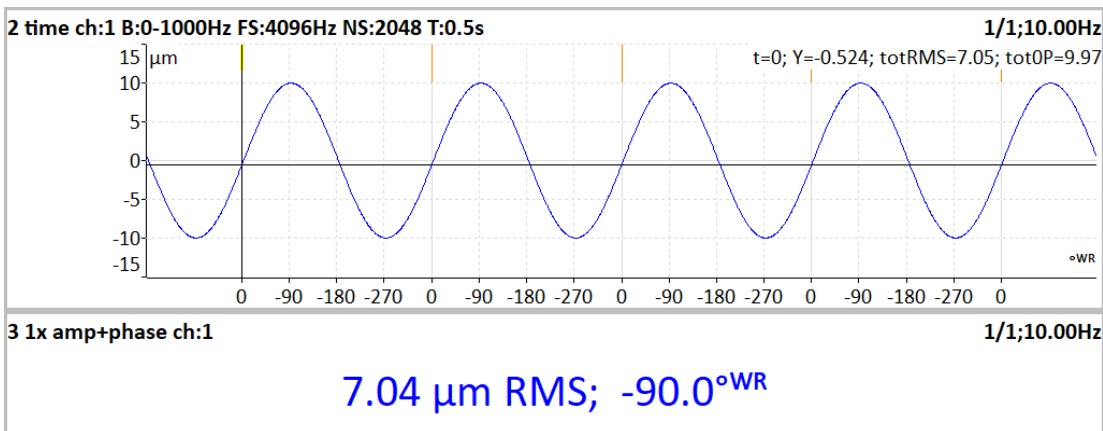

Time Axis Unit = degrees, Angles Counting = against rotation:

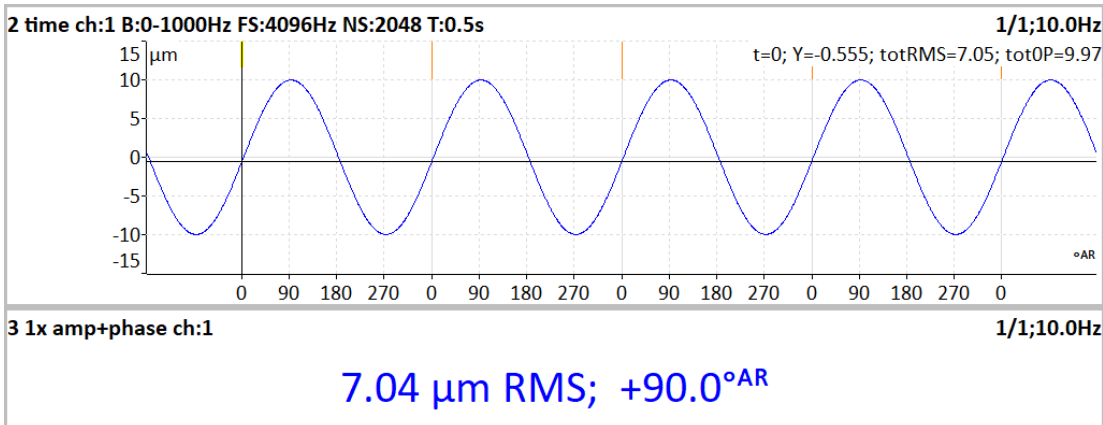

**FFT Output (for spectrum)**

- amplitude spectrum**
- power spectrum**
- amplitude spectral density**
- power spectral density (PSD)**
- energy spectral density (ESD)**

### ***FrF Format (for frf)***

When a FRF is used with force units on one channel and some vibration units on another channel, you may display the FRF in different units than the one in which it was measured. Alternate formats are created by performing math operations on the FRF:

Integration and differentiation: Acceleration can be changed to velocity or displacement.

Inversion: The FRF can be inverted, so it is input over output, rather than output over input.

#### **default**

No conversion of units is applied. The FRF is displayed in the same units as measured.

#### **accelerance**

acceleration / force

#### **mobility**

velocity / force

#### **compliance**

displacement / force

#### **dynamic mass**

force / acceleration

#### **mechanical impedance**

force / velocity

#### **dynamic stiffness**

force / displacement

### ***Bearing Faults***

#### **on, off**

If a bearing is defined in [Bearing Settings](#) and the measurement contains speed, then fault frequencies are displayed in spectrum.

**FTF** Fundamental Train Frequency

**BPFI** Ball Pass Frequency of Inner ring

**BPFO** Ball Pass Frequency of Outer ring

**BSF2** *Ball Spin Frequency \* 2 = Ball defect frequency*

BSF2 is the bearing failure frequency which you can see in the spectrum, because a spinning defective ball hits the bearing twice during one ball revolution: once the outer ring and once the inner ring.

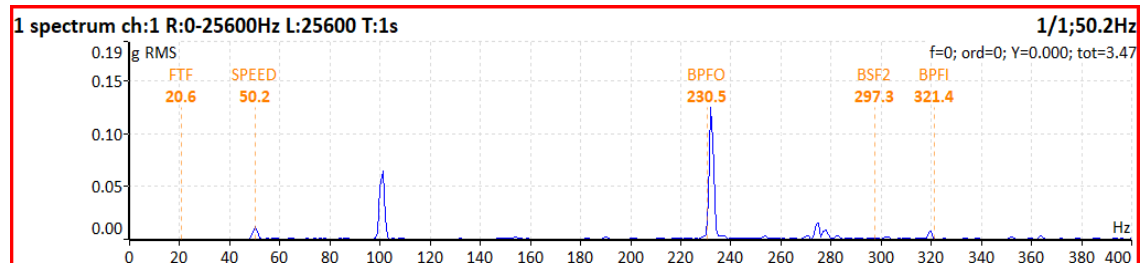

**Note!** If the measurement doesn't contain a speed information, then the cursor position represents the speed frequency.

#### ***FTF Period***

#### **on, off**

The FTF time period is displayed in the time signal

#### ***BSF2 Period***

#### **on, off**

The BSF2 time period is displayed in the time signal

#### ***BPFO Period***

#### **on, off**

The BPFO time period is displayed in the time signal

**BPFI Period**

**on, off**

The BPFI time period is displayed in the time signal

**Speed Period**

**on, off**

the speed time period is displayed in the time signal

**Graph Lines**

the spectrum can be drawn as a line through the tops of lines or as a discrete vertical line for each frequency  
continuous

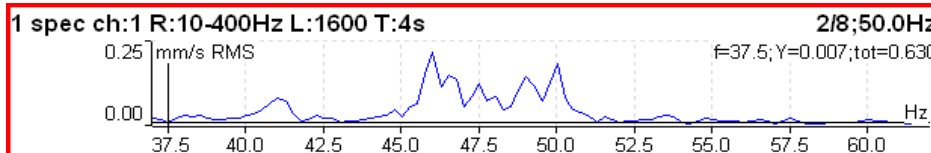

discrete

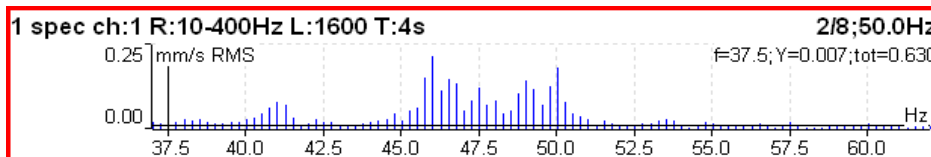

**FASIT**

It's a measurement type to find out machine's faults. There is a detailed description in the [FASIT](#) module chapter.

If FASIT is measured, the [Speed detection](#) is done before the measurement process.

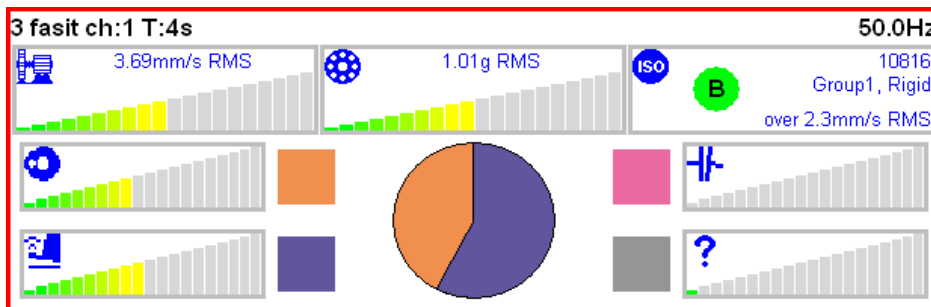

**Overall**

Typical example of the overall measurement is RMS value. You can see parameters settings in the picture below.

| Type               | overall<br>freerun, retrig |
|--------------------|----------------------------|
| All Channels       | no                         |
| Channel            | 1                          |
| Unit               | g                          |
| Detect Type        | RMS                        |
| Band fmin [Hz]     | 10                         |
| Band fmax [Hz]     | 1000                       |
| Sampling Freq [Hz] | 4096<br>by fmax            |
| Trigger Control    | off                        |
| Samples            | 4096<br>t = 1 s            |
| Averaging          | linear                     |
| Avg                | off<br>total t = 1 s       |

Save

**Note!** Overall measurement is such a measurement where you get one value. This value is a great pointer to evaluate machine's condition. It may be the easiest way how to inform the user that something is ongoing on the machine. Typical example is RMS value mentioned above.

[Type](#), [All channels](#), [Channel](#), [Unit](#), [Detect Type](#), [Band fmin](#), [Band fmax](#), [Sampling Freq](#), [Trigger control](#), [Samples](#), [Averaging](#), [Avg](#)

**Note!** Sampling Freq can be set for overall measurement type only when parameter band fmax value is set to 'none'. Otherwise, the option to set sampling frequency is greyed out.

Here is the example: RMS value of vibration velocity in the frequency range 10-1000 Hz is measured.

1 RMS ch:1 B:10-1000Hz NS:4096 T:1s 1/1;25.1Hz  
0.570mm/s

The first row contains used parameters. In the right top corner, there is an averaging index and number and a speed value.

Change the [Detect Type](#) to **True 0-P**.

1 0-P ch:1 B:10-1000Hz NS:4096 T:1s 1/1;25.1Hz  
1.98mm/s

**Note!** You can see that 1.98 is not 1.414 times bigger than 0.570. Some users mistakenly think that the formula  $0-P = 1.414 * RMS$  is valid for every signal. It is not true. **That formula is valid only for a pure sine wave!** The true RMS and true peak measurement are generally independent. The only rule is that the peak value is always larger than the RMS value.

Let's change the Avg to 8. Eight individual values (1 sec length) will be taken and the result will be the linear average of them ( $RV = (V1+V2+...+V8)/8$ ). The indication 8/8 is in the top right corner.

1 0-P ch:1 B:10-1000Hz NS:4096 T:1s 8/8;25.1Hz  
2.00mm/s

Let's change the Avg back to off and change the samples number to 32768. The measurement will be 8 sec long.

1 0-P ch:1 B:10-1000Hz NS:32768 T:8s 1/1;25.1Hz  
2.12mm/s

You see that the result is different from the previous value. It is clear, the max 0-P value in 8 sec signal is not equal to the average of 8 0-P values (which take 1 sec each).

Let's change the type back to RMS.

|                                      |            |
|--------------------------------------|------------|
| 1 RMS ch:1 B:10-1000Hz NS:32768 T:8s | 1/1;25.1Hz |
| 0.572mm/s                            |            |

Now change the length to 1 sec (4096 samples) and Avg=8.

|                                     |            |
|-------------------------------------|------------|
| 1 RMS ch:1 B:10-1000Hz NS:4096 T:1s | 8/8;25.1Hz |
| 0.572mm/s                           |            |

You see the same result. Both values are equal. The meaning of RMS differs from peak values. The RMS value depends only on the total time of measurement. It does not care if one long signal was taken or several shorter signals were averaged.

You can also define the signal length by the [Number of triggers](#), when you set the [Trigger control](#) to **on**.

|                    |                            |
|--------------------|----------------------------|
| Type               | overall<br>freerun, single |
| All Channels       | no                         |
| Channel            | 1                          |
| Unit               | mm/s                       |
| Detect Type        | RMS                        |
| Band fmin [Hz]     | 10                         |
| Band fmax [Hz]     | 1000                       |
| Sampling Freq [Hz] | 4096<br>by fmax            |
| ▶ Trigger Control  | on                         |
| Number of Triggers | 16                         |
| Averaging          | linear                     |
| Avg                | off                        |
| <b>Save</b>        |                            |

The *T* note changes to *R*, which means *Revolutions*, because the number of revolutions and tacho triggering is the most common usage.

|                             |            |
|-----------------------------|------------|
| 1 RMS ch:1 B:10-1000Hz R:16 | 1/1;25.1Hz |
| 0.545mm/s                   |            |

### ISO 20816 overall measurement

ISO 20816 limit values are also available for overall measurements. A green / amber-orange/ red point is displayed in front of the measured value according to the ISO limit.

If you want to use this function, you need to define the correct measurement parameters (RMS velocity measurement in the 10-1000Hz range) and a [ISO Machine Group](#) in the [Sensors](#) menu.

|  |  |
|--|--|
| 1 RMS ch:1 B:10-1000Hz NS:4096 T:1s  | 1/1;17.7Hz                                   |
| <span style="color: red; font-weight: bold; font-size: 1.2em;">D</span> 8.30mm/s RMS | ISO 10816: Group1, Rigid<br>over 7.1mm/s RMS |

The color of the circle is related to the machine condition class A, B, C, D (green for A or B, orange for C and red for D). The information about machine group and foundation are also displayed. The limit which the value is exceeding is also displayed at the bottom.

| Type          | spectrum<br>freerun, retrig   |
|---------------|-------------------------------|
| All Channels  | no                            |
| Channel       | 1                             |
| Window        | hanning                       |
| Unit          | mm/s                          |
| Zoom Spectrum | no                            |
| Band fmin[Hz] | 10                            |
| Range[Hz]     | 400<br>fs = 1024 Hz           |
| Lines         | 1600<br>t = 4 s, df = 0.25 Hz |
| Averaging     | linear                        |
| Avg           | 8<br>total t = 32 s           |
| Overlap       | 0%                            |
| Full Spectrum | no                            |

Save

[Type](#), [All channels](#), [Channel](#), [Window](#), [Unit](#), [Zoom spectrum](#), [Band fmin](#), [Range](#), [Lines](#), [Averaging](#), [Avg](#), [Overlap](#), [Full spectrum](#)

**Note!** Sampling is used for signal discretization in the time domain. Sampling frequency should be at least 2 times higher than signal frequency (low sampling frequency may cause signal distortion). Adash devices use sampling frequency 2,56 times higher than Fmax value.

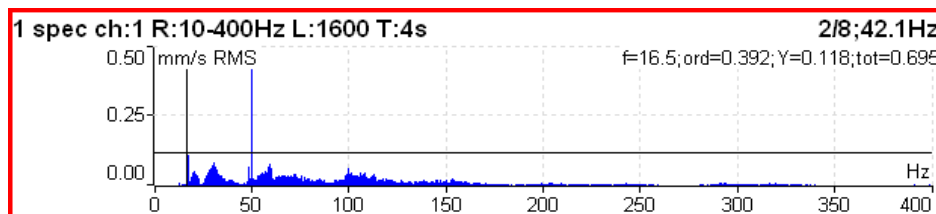

The information in top right corner contains averaging and speed and the cursor position (f) below them, order = f / speed (ord), cursor y-value (Y) and total RMS of spectrum (tot). The full list of symbols is in [Appendix C: Symbols and Abbreviations](#).

**Note!** Peak tracking from the beginning of the measurement until I move the cursor.

### Full spectrum

Set [Full spectrum](#) to **yes**. Remember to set the correct angles of both sensors. It influences the calculation. FFT is applied to a complex signal, the first channel is the real part and the second channel is the imaginary part.

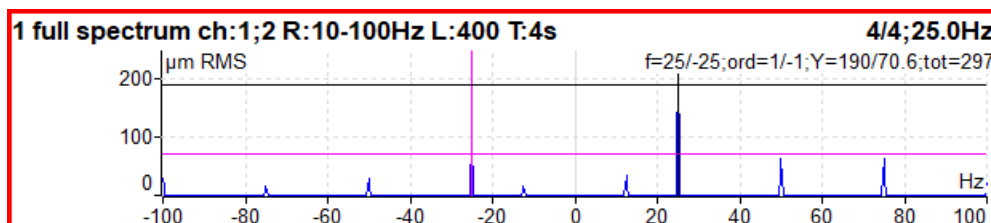

**Note!** A cursor is displayed on both sides. Different colors are used. Both cursor values are displayed.

**Attention!** The correct setting of A channel number and B is critical for the correct result. If this setting is wrong, then the negative and the positive sides are interchanged. Firstly, we find the angle between A and B, which is less than 180° (usually it is 90°). The rotation mark must be on A first and then on B.

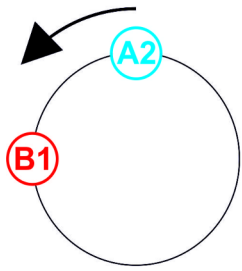

**CORRECT**

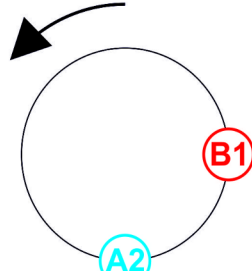

**CORRECT**

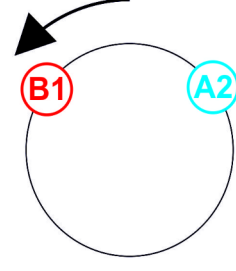

**CORRECT**

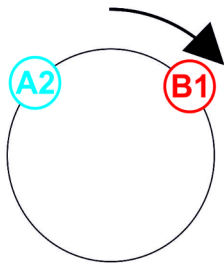

**CORRECT**

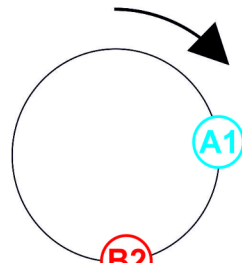

**CORRECT**

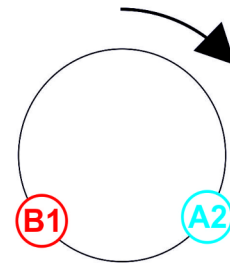

**CORRECT**

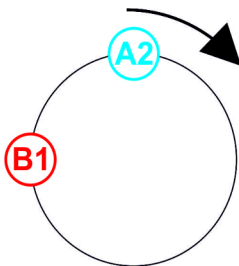

**WRONG**

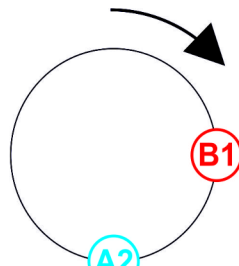

**WRONG**

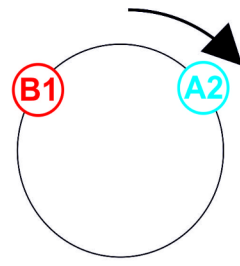

**WRONG**

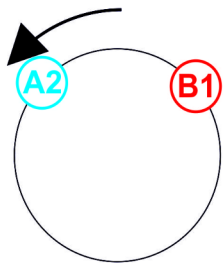

**WRONG**

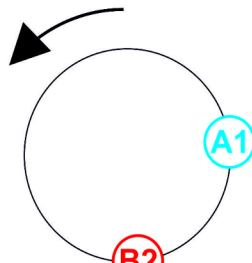

**WRONG**

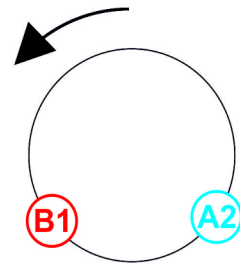

**WRONG**



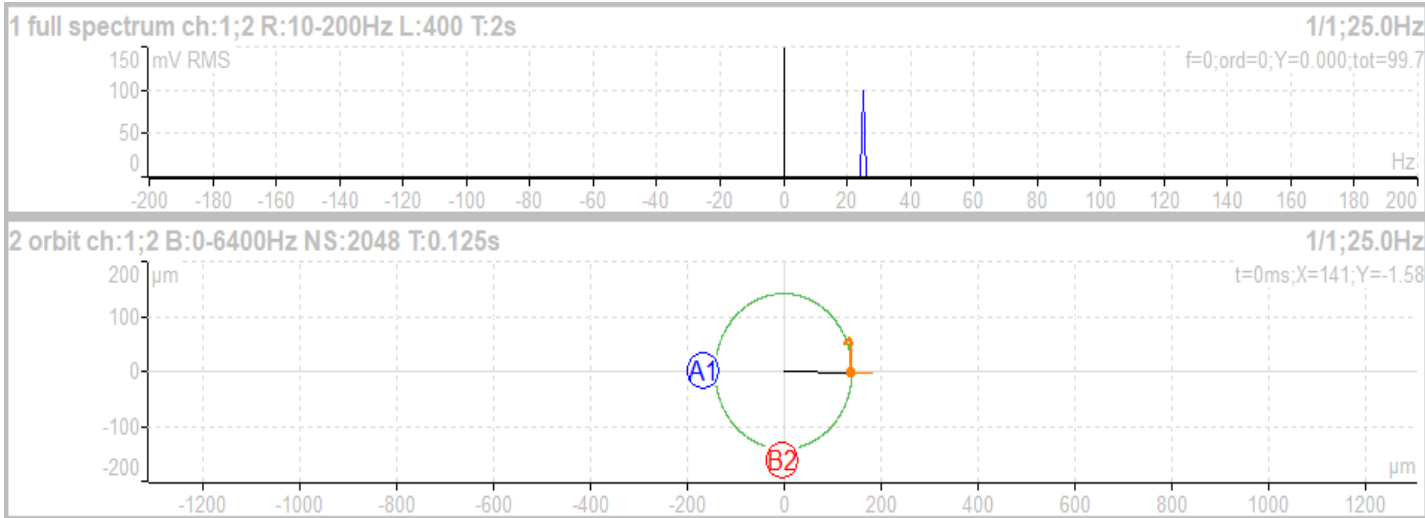

Vibration (orbit arrow) has the same direction as rotation.

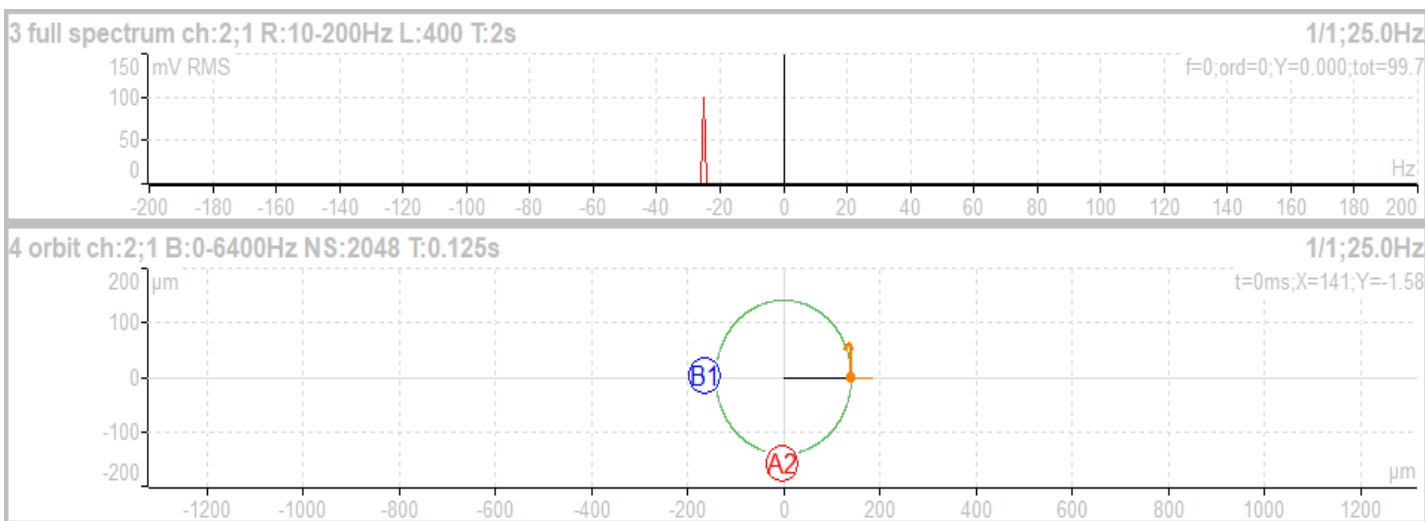

Vibration (orbit arrow) has the opposite direction as rotation.

## Time

| Type               | time                 |
|--------------------|----------------------|
|                    | freerun, retrig      |
| All Channels       | no                   |
| Channel            | 1                    |
| Unit               | g                    |
| Band fmin [Hz]     | 10                   |
| Band fmax [Hz]     | 1000                 |
| Sampling Freq [Hz] | 4096<br>by fmax      |
| Trigger Control    | off                  |
| Samples            | 4096<br>t = 1 s      |
| Avg                | off<br>total t = 1 s |
| <b>Save</b>        |                      |

[Type](#), [All channels](#), [Channel](#), [Unit](#), [Band fmin](#), [Band fmax](#), [Sampling Freq](#), [Trigger control](#), [Samples](#), [Avg](#)

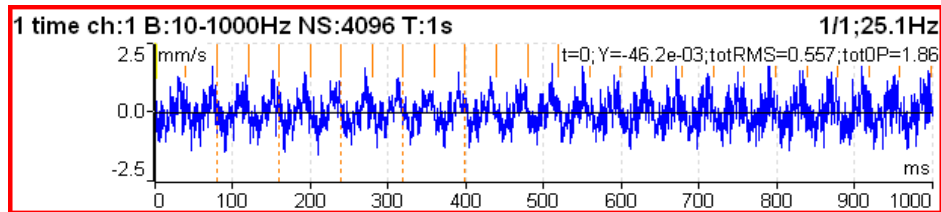

Similar parameter like for overall is used. Orange short vertical lines at the top of the graph indicate tachometer inputs. Total RMS (totRMS) and true peak (totOP) values are displayed beside the cursor value.

### Time signal averaging

For averaging, you need to set some [Trigger Source](#) in the [Trigger Settings](#) menu, because only triggered time signals can be averaged.

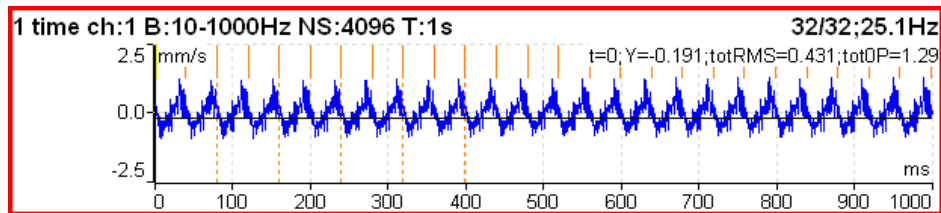

You see the effect of averaging. The signal noise decreases.

### Time signal with DC offset (gap)

You can measure a gap value from a DC channel simultaneously with a **displacement** time signal. This gap value is added to the time signal.

#### How to connect a sensor

A displacement sensor must be connected to an AC and to a DC channel at the same time. You can find where all channel pins are in the [Input Channels](#) chapter. You can order a cable with the right connection from your instrument vendor.

#### How to setup a sensor

Open the [Sensors](#) menu and select the used AC channel (the channel where the sensor is connected). Setup sensitivity and other values like usually. There is one more item for a displacement sensor, [DC gap channel](#). Its value is not defined by default. You need to enter the value of your DC channel here (this number is usually the same as the AC channel). Then setup an associated DC sensor (sensitivity, unit and position must be the same as in AC sensor).

#### Measurement

Setup and measure a time signal as usually. Time signal is modulated to a DC gap value measured from the associated DC channel.

First picture shows the signal without gap.

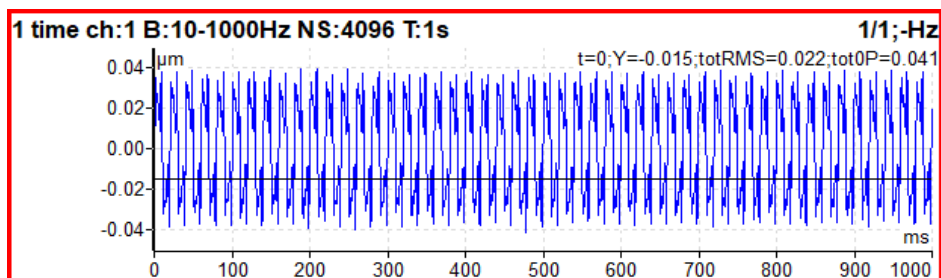

And the same signal with a gap is in the picture below.

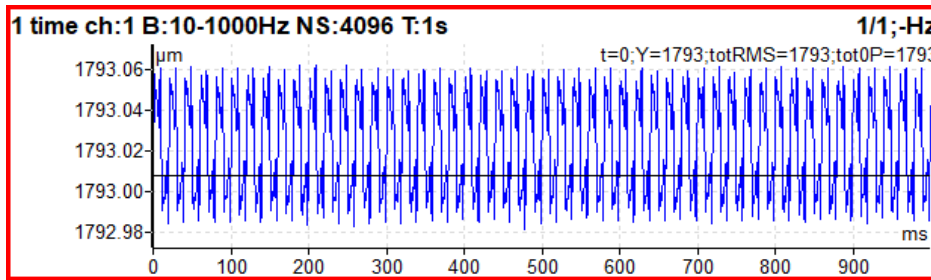

### G-demod Spectrum

|                 |                                     |
|-----------------|-------------------------------------|
| Type            | g-demod spectrum<br>freerun, retrig |
| All Channels    | no                                  |
| Channel         | 1                                   |
| Window          | hanning                             |
| Unit            | g                                   |
| DEMODO fmin[Hz] | 500                                 |
| DEMODO fmax[Hz] | 25600<br>fs = 65536 Hz              |
| Range[Hz]       | 800                                 |
| Lines           | 800<br>t = 1 s, df = 1 Hz           |
| Averaging       | linear                              |
| Avg             | 8<br>total t = 8 s                  |
| Overlap         | 0%                                  |

Save

[Type](#), [All channels](#), [Channel](#), [Window](#), [Unit](#), [DEMODO fmin](#), [DEMODO fmax](#), [Range](#), [Lines](#), [Averaging](#), [Avg](#), [Overlap](#)

The signal is filtered in set range (DEMODO fmin, DEMODO fmax) and then demodulated. Only an acceleration or a voltage unit can be used. No integration of signal is enabled.

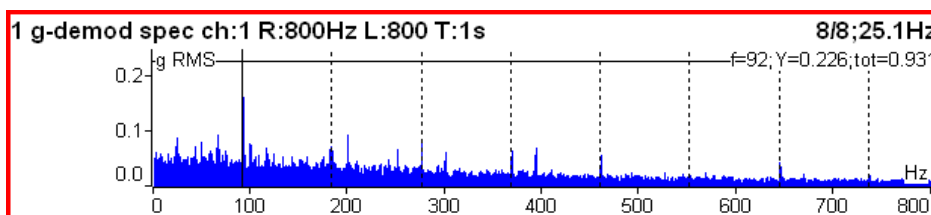

**Example:** the demodulated frequency 92Hz with harmonics.

**Note!** Demodulated spectrum is mostly used for bearing faults.

## G-demod Time

| Type           | g-demod time<br>freerun, retrigger |
|----------------|------------------------------------|
| All Channels   | no                                 |
| Channel        | 1                                  |
| Unit           | g                                  |
| DEMOD fmin[Hz] | 500                                |
| DEMOD fmax[Hz] | 25600<br>fs = 65536 Hz             |
| Samples        | 512<br>t = 0.00781 s               |

Save

[Type](#), [All channels](#), [Channel](#), [Unit](#), [DEMOD fmin](#), [DEMOD fmax](#), [Samples](#)

This function enables you to see the signal, when the standard envelope demodulation is used. The signal is filtered in a range (DEMOD fmin, DEMOD fmax) and then demodulated. Only an acceleration or a voltage unit can be used. No integration of signal is enabled.

## G-demod Overall

| Type           | g-demod overall<br>freerun, retrigger |
|----------------|---------------------------------------|
| All Channels   | no                                    |
| Channel        | 1                                     |
| Unit           | g                                     |
| Detect Type    | RMS                                   |
| DEMOD fmin[Hz] | 500                                   |
| DEMOD fmax[Hz] | 25600<br>fs = 65536 Hz                |
| Samples        | 8192<br>t = 0.125 s                   |
| Averaging      | linear                                |
| Avg            | off<br>total t = 0.125 s              |

Save

[Type](#), [All channels](#), [Channel](#), [Unit](#), [Detect Type](#), [DEMOD fmin](#), [DEMOD fmax](#), [Samples](#), [Averaging](#), [Avg](#)

The signal is filtered in a set range (DEMOD fmin, DEMOD fmax) and then demodulated. Only an acceleration or a voltage unit can be used. No integration of signal is enabled.

1 g-demod RMS ch:1 B:500-25600Hz NS:8192 T:0.125s 1/1;25.1Hz  
4.32g

## amp+phase

The amplitude and phase on speed frequency or its multiple (order) or on manually entered frequency.

|            |                              |
|------------|------------------------------|
| Type       | amp+phase<br>freerun, single |
| Channel    | 1                            |
| Unit       | mm/s                         |
| Sampling   | standard                     |
| Averaging  | linear                       |
| Avg        | off                          |
| Frequency  | speed                        |
| Order      | 1                            |
| Resolution | speed / 4<br>t = 4 revs      |
| Save       |                              |

[Type](#), [All channels](#), [Channel](#), [Unit](#), [Sampling](#), [Averaging](#), [Avg](#), [Frequency](#), [Order](#), [Resolution](#)



By default, amp+phase is measured on speed frequency (Order = 1). However, you may define any value as the [Order](#) for the measurement. For example, if you want to measure amplitude and phase on 1/3x speed frequency, then you enter the order as 0.333333. The order value is announced in the graph's information line, the "1x" on the picture above means the order value is 1. Thus, the speed frequency is used for measurement.

**Note!** Remember to set the appropriate resolution according to the used order. See [Resolution](#) for more details.

Furthermore, you may enter any frequency using the [Frequency](#) parameter. In this case, the *order* parameter is not available. The [Resolution](#) parameter is entered as a fraction of the entered frequency. The entered frequency is announced by the "f:" label in graph's information line.



## Orbit

|                    |                           |
|--------------------|---------------------------|
| Type               | orbit<br>freerun, retrig  |
| All Channels       | no                        |
| Channel A          | 1                         |
| Channel B          | 2                         |
| Unit               | µm                        |
| Band fmin [Hz]     | none<br>1 Hz (integrator) |
| Band fmax [Hz]     | 800                       |
| Sampling Freq [Hz] | 2048<br>by fmax           |
| Trigger Control    | off                       |
| Samples            | 4096<br>t = 2 s           |
| Avg                | off<br>total t = 2 s      |
| Save               |                           |

[Type](#), [All channels](#), [Channel A](#), [Channel B](#), [Unit](#), [Band fmin](#), [Band fmax](#), [Sampling Freq](#), [Trigger control](#), [Samples](#), [Avg](#)

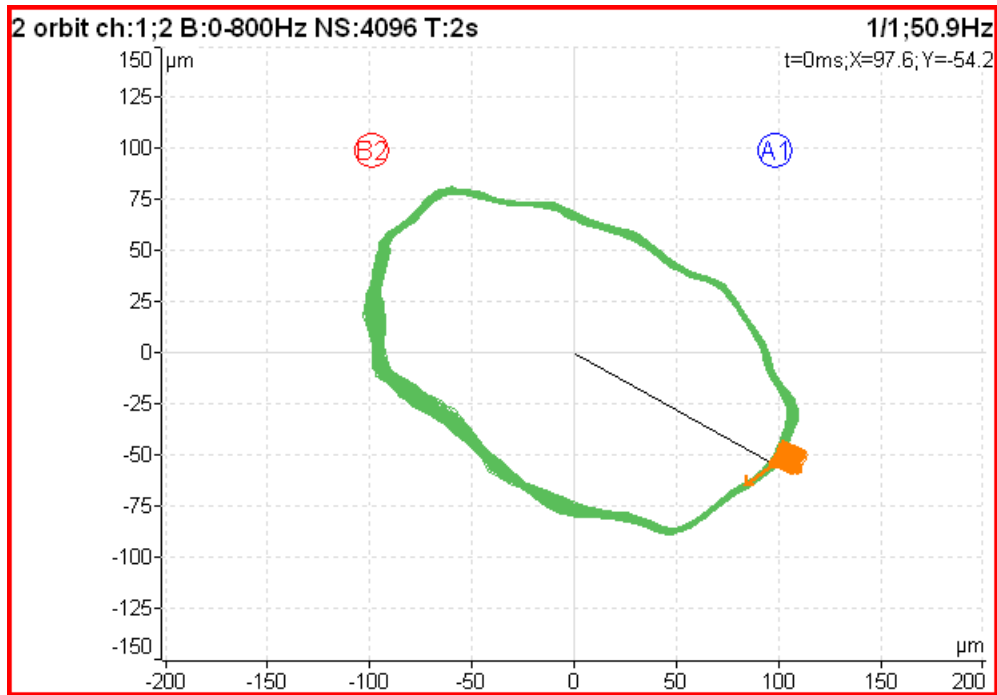

The **A1** means, that the [A channel number](#) is set to AC1 input and similarly **B2** means [B channel number](#) is set to AC2 input.

The position of **A1** and **B2** matches the sensor angles defined in [AC Sensors / Position](#). Knowledge of those angles enables the drawing of the correct shape of the orbit.

**Attention!** Correct AC sensors [Position](#) must be set for the correct calculations.

### Orbit averaging

[Trigger Source](#) must be set to enable orbit averaging like in [Time signal averaging](#).

### Orbit measurement with DC offset (gap)

An orbit contains two time signals. Each time signal could be modulated to a gap value as referred in [Time signal with DC offset \(gap\)](#) chapter. If you setup gap channels for orbit's time signals, the resulting orbit will be displayed with an offset.

### Filtered Orbit

| Type         | filtered orbit<br>freerun, retrigger |
|--------------|--------------------------------------|
| All Channels | no                                   |
| Channel A    | 1                                    |
| Channel B    | 2                                    |
| Unit         | µm                                   |
| Orders       | 1-10                                 |
| Averaging    | linear                               |
| Avg          | off                                  |

**Save**

[Type](#), [All channels](#), [Channel A](#), [Channel B](#), [Unit](#), [Orders](#), [Averaging](#), [Avg](#)

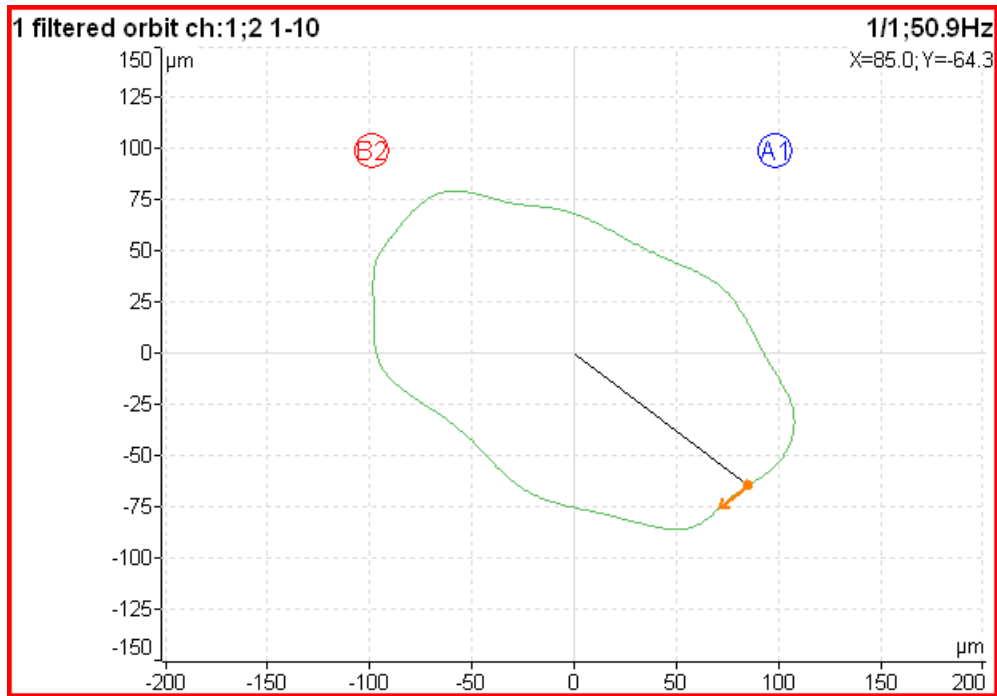

Filtered orbit is built up from two order analysis readings. Correct sensors [Position](#) (angle) must be set for the correct calculations as for standard orbit graph. You can switch displayed orders on or off in the [Graph Properties](#) menu.

### Speed

The machine speed (revolutions) is measured.

|           |                             |
|-----------|-----------------------------|
| Type      | speed<br>freerun, retrigger |
| Unit      | Hz                          |
| Averaging | linear                      |
| Avg       | off                         |
| Save      |                             |

[Type](#), [Unit](#), [Averaging](#), [Avg](#)

When a tachometer probe is used (connected to the TRIG input), then the measurement is triggered when a signal on TRIG input exceeds the [Tacho / External / Trig Level \[V\]](#) value. Tacho impulses are marked by short lines in the time signal graph.

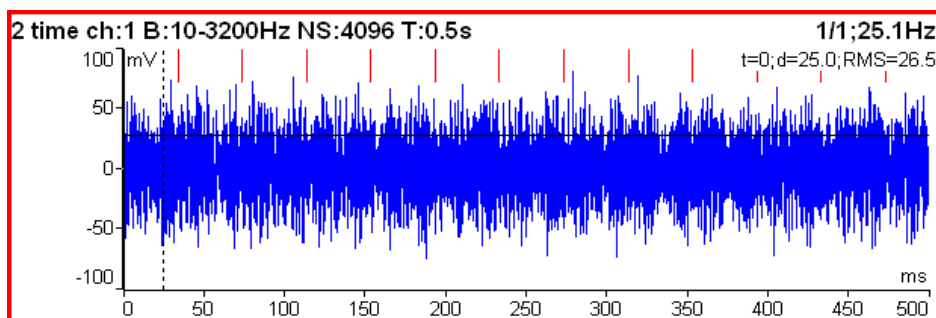

The speed measurement is taken 8 times every second. The value is evaluated from 3 tacho events in a time signal. When averaging is required, then more values are used. But keep in mind that only 8 values are taken in one second.

**Note!** The TRIG input signal is evaluated regardless of you having the speed measurement defined. If the signal contains pulses, the speed will be calculated and stored in data headers of all measurements in the set. Only if the [Trigger Source](#) is set to **external**, no speed is evaluated.

## ACMT time

| Type           | ACMT time<br>freerun, single |
|----------------|------------------------------|
| Channel        | 1                            |
| Unit           | g                            |
| Band fmin [Hz] | 500                          |
| ACMT FS [Hz]   | 1024                         |
| Samples        | 8192<br>t = 8 s              |
| <b>Save</b>    |                              |

[Type](#), [Channel](#), [Unit](#), [Band fmin](#), [ACMT FS](#), [Samples](#)

It enables the measurement of long time signals and compresses them. It is used when you need high frequency range, for example, 25.6kHz. The highpass filtering is used (Band fmin). The basic property of ACMT is resampling the initial high frequency sampling to low [ACMT Sampling](#) frequency sampling.

The compressed ACMT time signal can keep the **RMS** or **TRUE PEAK** of the original signal. Use the [Detect Type](#) parameter for selection. RMS value enables better trending.

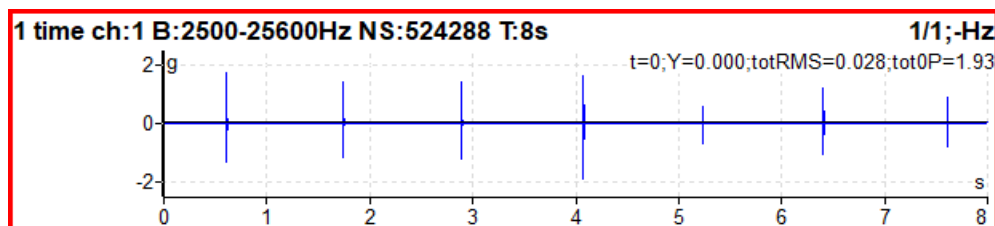

The original time signal which contains shocks is 8 sec long. The signal contains 524288 samples.

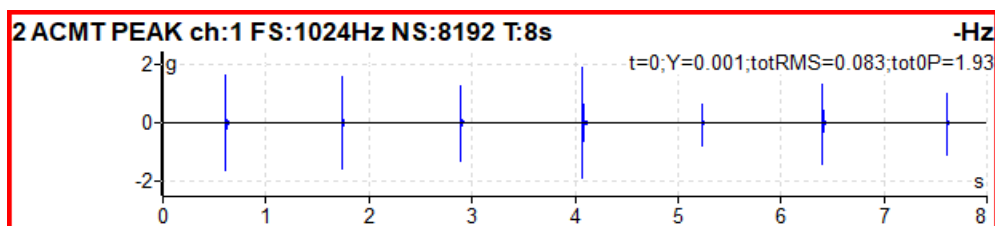

The ACMT time signal. You can see the same shocks, but the signal contains only 8192 samples.

## ACMT g-demod time

Newly you can use measurement type ACMT g-demod time.



|                  |                                      |
|------------------|--------------------------------------|
| Type             | ACMT g-demod time<br>freerun, single |
| Channel          | 1                                    |
| Unit             | g                                    |
| DEMODO fmin [Hz] | 500                                  |
| ACMT FS [Hz]     | 1024                                 |
| Samples          | 8192<br>t = 8 s                      |
| <b>Save</b>      |                                      |

[Type](#), [Channel](#), [Unit](#), [DEMODO fmin](#), [ACMT FS](#), [Samples](#)

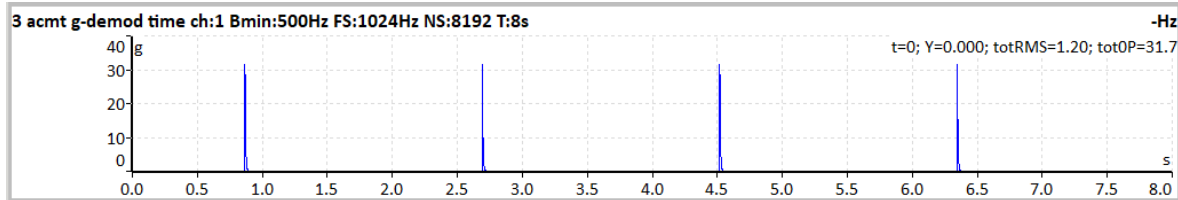

### ACMT g-demod spectrum

Newly you can use measurement type ACMT g-demod spectrum.

**Note!** You can see Range under ACMT Sampling – you don't have to enter it manually as in type demod spectrum, it is automatically derived from the ACMT Sampling.

|                  |  |
|------------------|--|
| Type             | ACMT g-demod spectrum<br>freerun, single |
| Channel          | 1  |
| Window           | hanning                                  |
| Unit             | g  |
| DEMODO fmin [Hz] | 500                                      |
| ACMT FS [Hz]     | 1024<br>Range = 400 Hz                   |
| Lines            | 3200<br>t = 8 s, df = 0.125 Hz           |
| Averaging        | linear                                   |
| Avg              | off<br>total t = 8 s                     |
| Overlap          | 0%                                       |
| <b>Save</b>      |  |

[Type](#), [Channel](#), [Window](#), [Unit](#), [DEMODO fmin](#), [ACMT FS](#), [Lines](#), [Averaging](#), [Avg](#), [Overlap](#)

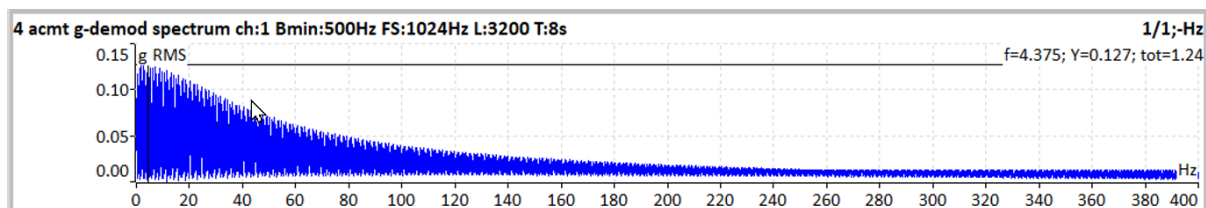

### Orders

The amplitude and phase on speed frequency, harmonic frequencies and possibly a subharmonic frequency.

|              |                              |
|--------------|------------------------------|
| Type         | orders<br>freerun, retrigger |
| All Channels | no                           |
| Channel      | 1                            |
| Unit         | μm                           |
| Orders       | 1-10                         |
| Averaging    | linear                       |
| Avg          | off                          |
| Resolution   | speed / 4<br>t = 4 revs      |

Save

[Type](#), [All channels](#), [Channel](#), [Unit](#), [Orders](#), [Averaging](#), [Avg](#), [Resolution](#)

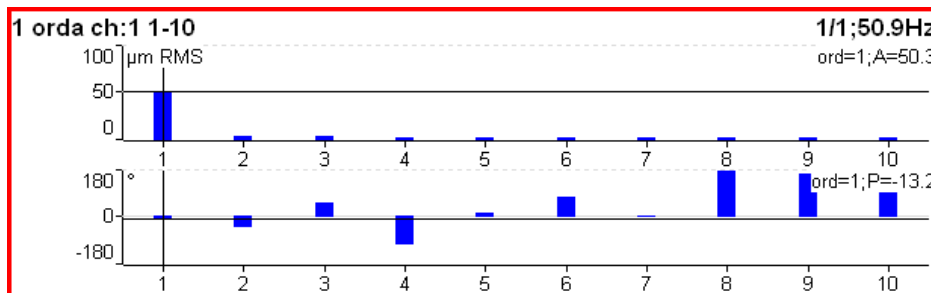

### Order Spectrum (Order Tracking Analysis)

|               |                                      |
|---------------|--------------------------------------|
| Type          | order spectrum<br>freerun, retrigger |
| All Channels  | no                                   |
| Channel       | 1                                    |
| Window        | hanning                              |
| Unit          | mm/s                                 |
| Band fmax[Hz] | 3200<br>Low speed = 0.5 Hz           |
| Lines         | 400                                  |
| Orders        | 25<br>t = 16 revs                    |
| Averaging     | linear                               |
| Avg           | off                                  |
| Full Spectrum | no                                   |

Save

[Type](#), [All channels](#), [Channel](#), [Window](#), [Unit](#), [Band fmax](#), [Lines](#), [Orders](#), [Averaging](#), [Avg](#), [Full spectrum](#)

The [Band fmax](#) defines the range of a spectrum. All frequencies above this range will be zeroed. Defining this range is necessary when you need high number of orders. The required range is equal to the number of orders multiplied by a speed frequency. Be careful, higher [Band fmax](#) increases the minimum speed which can be used. You can see this minimum below as the note "Low speed". When the speed is lower than this value, then a measurement error shows.

The number of revolutions is displayed below the number of orders (16 revs in image). Such number of revolutions is needed for one spectrum calculation. We cannot display it in time, like for spectrum. One revolution is the time quantity for order spectrum.

The 4 revolutions is the minimum number. It means that lines number must be 4 times greater than orders number as the minimum.

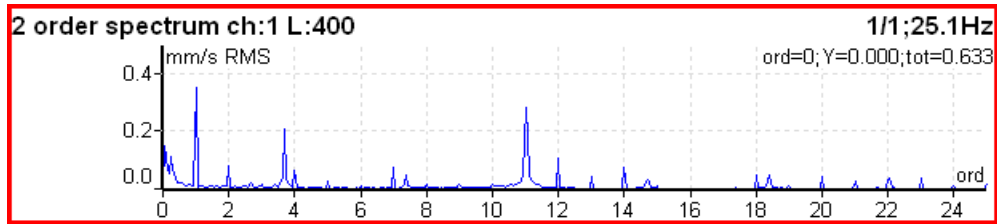

### Order full spectrum

Set [Full spectrum](#) to **yes**. Remember to set the correct angles of both sensors. It influences the calculation. FFT is applied to a complex signal, the first channel is the real part and the second channel is the imaginary part.

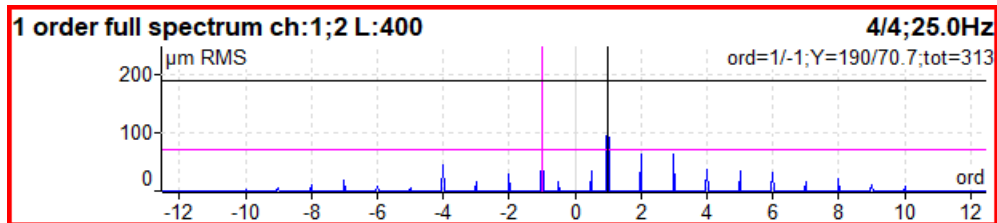

**Note!** A cursor is displayed on both sides. Different colors are used. Both cursor values are displayed.

**Attention!** The correct setting of [Channel A](#) and [Channel B](#) is critical for the correct result. If this setting is wrong, then the negative and the positive sides are interchanged. See the [Full spectrum](#) chapter for details.

### Phase Shift

Measurement of phase shift between two channels, amplitude ratio, and coherence on speed frequency or on manually entered frequency.

| Type         | phase shift<br>freerun, retrig |
|--------------|--------------------------------|
| All Channels | no                             |
| Channel A    | 1                              |
| Channel B    | 2                              |
| Sampling     | standard                       |
| Avg          | off                            |
| Frequency    | speed                          |
| Order        | 1                              |
| Resolution   | speed / 4<br>t = 4 revs        |

**Save**

[Type](#), [All channels](#), [Channel A](#), [Channel B](#), [Sampling](#), [Avg](#), [Frequency](#), [Order](#), [Resolution](#)

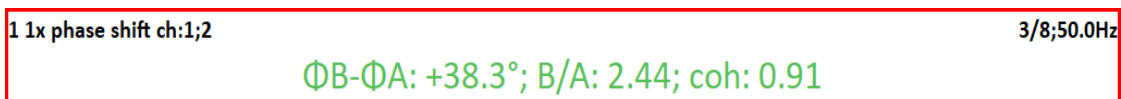

The result contains:

- phase shift value in degrees,
- amplitude ratio (ampl B/ ampl A),

- coherence

If phase shift is reliable, coherence must be higher than 0.8.

By default, the phase shift is measured on speed frequency (Order = 1). However, you may define any value as the [Order](#) for the measurement. For example, if you want to measure amplitude and phase on 1/3x speed frequency, then you enter the order as 1/3. The order value is announced in the graph's information line, the "1x" on the picture above means the order value is 1. Thus, the speed frequency is used for measurement.

Furthermore, you may enter any frequency using the [Frequency](#) parameter. In this case, the order parameter is not available, the [Resolution](#) parameter is entered as a fraction of the frequency and the entered frequency is announced by the "f:" label in graph's information line.

1 phase shift ch:1;2 f:38Hz 1/1;50.0Hz  
 $\Phi_B - \Phi_A: +98.3^\circ; B/A: 0.342; coh: 0.91$

## DC

A direct DC signal can be measured by this function.

|              |                          |
|--------------|--------------------------|
| Type         | dc<br>freerun, retrigger |
| All Channels | no                       |
| Manual Entry | no                       |
| Channel      | 1                        |
| Unit         | mV                       |
| Averaging    | linear                   |
| Avg          | off                      |
| <b>Save</b>  |                          |

[Type](#), [All channels](#), [Channel](#), [Unit](#), [Averaging](#), [Avg](#)

1 dc ch:1 22.6 °C

If you want to enter the value manually, select **Manual Entry** as **yes**. All manual inputs are required before the measurement. A new window for each one appears.

Enter value [°C]  
 Manual Entry (Graph1)  
 22.6|

# Frf

## Frequency Response Function

|              |                              |
|--------------|------------------------------|
| Type         | frf<br>freerun, retriq       |
| All Channels | no                           |
| Input        | 1                            |
| Window       | transient                    |
| Shift[ms]    | 97.2                         |
| Length[ms]   | 6.35                         |
| Output       | 2                            |
| Window       | exponential                  |
| Shift[ms]    | 97.7                         |
| Length[ms]   | 196                          |
| Result Type  | H1                           |
| Range[Hz]    | 800<br>fs = 2048 Hz          |
| Lines        | 1600<br>t = 2 s, df = 0.5 Hz |
| Avg          | 4<br>total t = 8 s           |
| Overlap      | 0%                           |

Save

[Type](#), [All channels](#), [Input channel](#), [Output channel](#), [Window](#), [Result Type](#), [Range](#), [Lines](#), [Avg](#), [Overlap](#)

Coherence is displayed in the amplitude graph. The short horizontal line on Y axis is on the position of value = 1 for coherence.

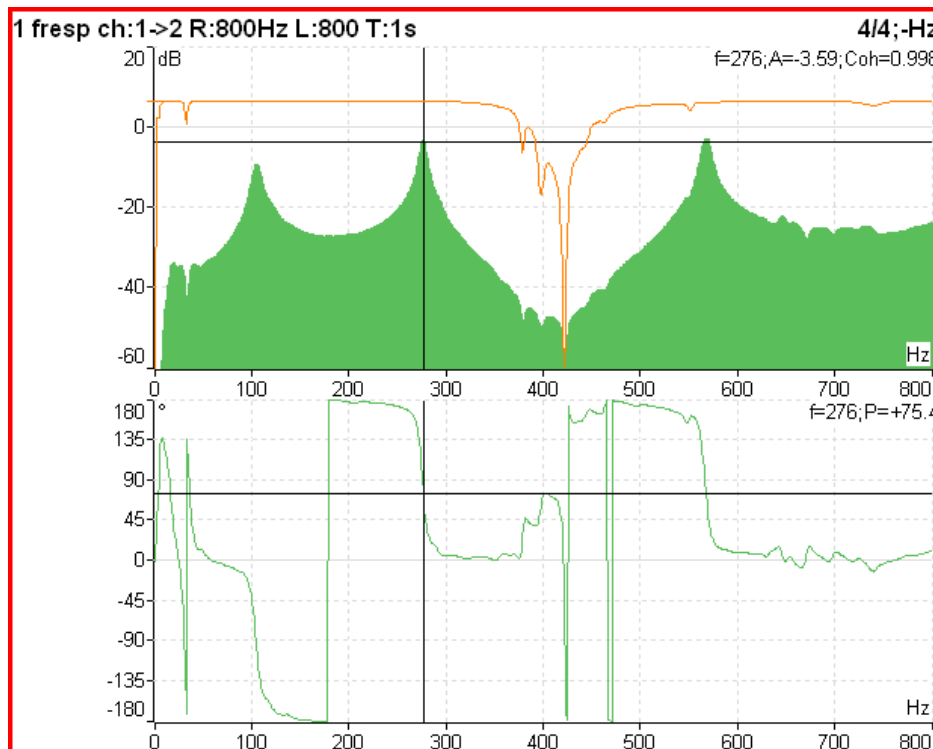

When you set the [View \(for frf\)](#) Frf view to **time**, you see the time signals from both channels.

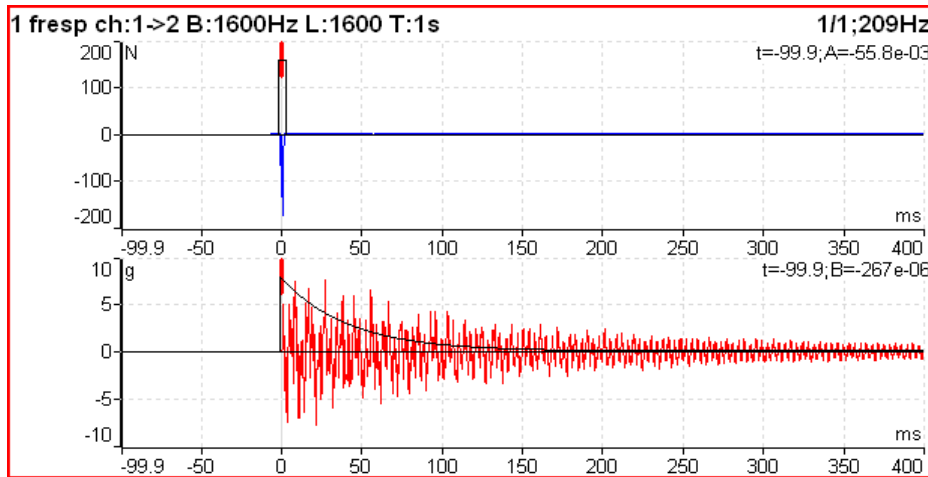

You may use this view to easily set [Window](#) parameters. Set the button mode to **Spectral window**. Now you can simply shift the windows or change their length.

**Frf Format**

When a FRF is used with force units on one channel and some vibration units on another channel, you may change the units in which the frf is displayed using [Graph Properties](#) / [Frf Format](#).

**Octave Spectrum, Sound Level and Equivalent Sound Level**

All parameters are described in the [Octave Analysis](#) chapter. Exponential averaging is not available in the Analyzer module.

**Center line**

This measurement is often used for turbines. Its values define the static position of a shaft in a bearing. Signals from proximity sensors must be connected to DC channels. We need to remove the AC part and hold the DC part. The DC inputs work in that way.

| Type         | center line<br>freerun, retrigger |
|--------------|-----------------------------------|
| All Channels | no                                |
| Channel A    | 1                                 |
| Channel B    | 2                                 |
| Unit         | µm                                |
| Avg          | off                               |

**Save**

[Type](#), [All channels](#), [Channel A](#), [Channel B](#), [Unit](#), [Avg](#)

*Center line* is related to the [Orbit](#) measurement. In orbit, we see the shape around the (0,0) position. In center line, we see the position of the shaft center without the shape of an orbit.

**Attention!** The correct DC sensors [Position](#) must be set for correct calculations.

1 center line ch:1;2 1/1;-Hz  
A:2767µm; B:1768µm; X:-706µm; Y:-3206µm

Two couples of values are displayed, A+B and X+Y. The A, B values represent distances of sensors from the reference position defined by the offset value. The X, Y values represent these positions according to the

Cartesian X, Y coordinates (The position (0,0) corresponds to the position where A, B are equal to their offsets). The polar graph is displayed for trend.

### Smax

It is the measurement of the maximum deflection on an [Orbit](#). The correct sensors [position](#) must be set for the correct calculations as for standard orbits.

| Type               | Smax<br>freerun, retrigger |
|--------------------|----------------------------|
| All Channels       | no                         |
| Channel A          | 1                          |
| Channel B          | 2                          |
| Unit               | µm                         |
| Band fmin [Hz]     | 10                         |
| Band fmax [Hz]     | 1000                       |
| Sampling Freq [Hz] | 4096<br>by fmax            |
| Trigger Control    | off                        |
| Samples            | 4096<br>t = 1 s            |
| Averaging          | linear                     |
| Avg                | off<br>total t = 1 s       |

**Save**

[Type](#), [All channels](#), [Channel A](#), [Channel B](#), [Unit](#), [Band fmin](#), [Band fmax](#), [Sampling Freq](#), [Trigger control](#), [Samples](#), [Averaging](#), [Avg](#)



In the next picture, you can see the Smax value highlighted on the orbit.

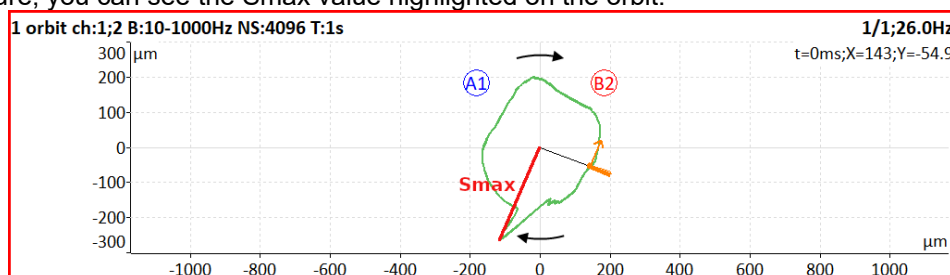

### Complex Smax

It is the measurement of the maximum deflection on an [Orbit](#) together with an angle (i.e., position) of this deflection. In other words, it is an Smax measurement with the position of maximum deflection. The correct sensors [position](#) must be set for correct calculations as for standard orbits.

| Type               | complex Smax<br>freerun, retrigger |
|--------------------|------------------------------------|
| All Channels       | no                                 |
| Channel A          | 1                                  |
| Channel B          | 2                                  |
| Unit               | $\mu\text{m}$                      |
| Band fmin [Hz]     | 10                                 |
| Band fmax [Hz]     | 1000                               |
| Sampling Freq [Hz] | 4096<br>by fmax                    |
| Trigger Control    | off                                |
| Samples            | 4096<br>t = 1 s                    |
| Averaging          | linear                             |
| Avg                | off<br>total t = 1 s               |

**Save**

[Type](#), [All channels](#), [Channel A](#), [Channel B](#), [Unit](#), [Band fmin](#), [Band fmax](#), [Sampling Freq](#), [Trigger control](#), [Samples](#), [Averaging](#), [Avg](#)

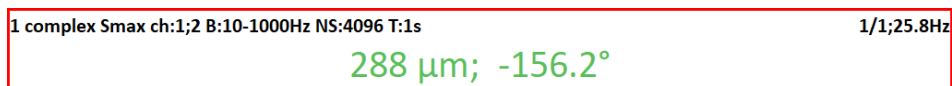

In the next picture, you can see the Smax value and its position highlighted on the orbit.

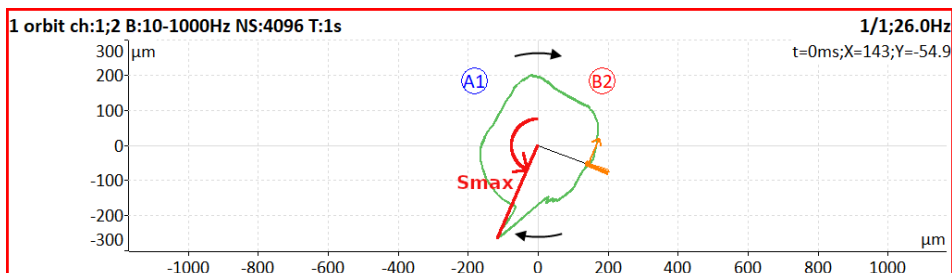

**Note!** The angle of the maximum displacement can sometimes be accidental. Let's consider a perfect circle shape orbit as an example below. In this case, the Smax angle is a random number, and when averaging such Smax, the angle is undefined.

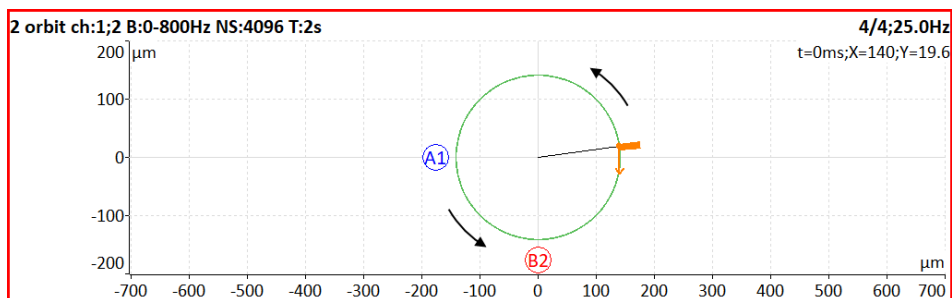



|               |                             |
|---------------|-----------------------------|
| Type          | cepstrum<br>freerun, retrig |
| All Channels  | no                          |
| Channel       | 1                           |
| Window        | hanning                     |
| Unit          | g                           |
| Band fmin[Hz] | 10                          |
| Range[Hz]     | 800<br>fs = 2048 Hz         |
| Lines         | 400<br>t = 0.5 s, df = 2 Hz |
| Avg           | off<br>total t = 0.5 s      |
| Overlap       | 0%                          |

Save

[Type](#), [All channels](#), [Channel](#), [Window](#), [Unit](#), [Band fmin](#), [Range](#), [Lines](#), [Avg](#), [Overlap](#)

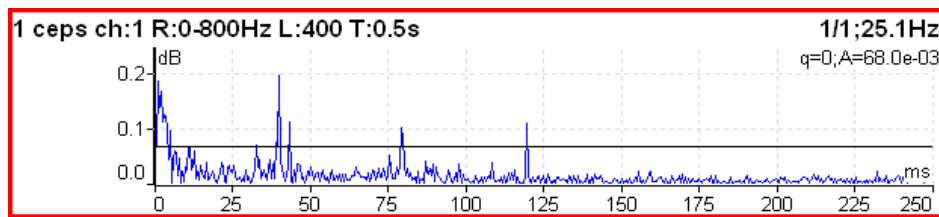

Used algorithm is:  

$$\text{cepstrum}(x) = \text{ifft}(\text{fft}(\log_{10}(\text{abs}(\text{fft}(x))))))$$
 x input signal  
 fft fast fourier transform  
 abs absolute value  
 log10 common logarithm  
 ifft inverse fast fourier transform

## Ultrasound

|      |                               |
|------|-------------------------------|
| Type | ultrasound<br>freerun, retrig |
|------|-------------------------------|

Save

1 ultrasound -Hz  
Level: 52 dB, Shock Factor: 1.4

Two values are displayed. The **Level** of sound in dB (30-50kHz range) and **Shock Factor**. The *Shock factor* is defined as Peak value divided by RMS value. It means a value of 1.4 for pure sine. Higher values mean that transient shock events are in the sound signal.

**Note!** An ultrasound sensor (microphone) is required.

There is detailed description in the [Ultrasound](#) chapter.

|                    |                                     |
|--------------------|-------------------------------------|
| Type               | record<br>freerun, retrigger        |
| Sampling Freq [Hz] | 65536<br>Frequency Range = 25600 Hz |
| AC1                | on                                  |
| AC2                | off                                 |
| AC3                | off                                 |
| AC4                | off                                 |
| DC1                | off                                 |
| DC2                | off                                 |
| DC3                | off                                 |
| DC4                | off                                 |
| Speed              | off                                 |
| Length             | manually stopped                    |
| Start of Rec       | freerun                             |
| <b>Save</b>        |                                     |

1 record  
00:00:25 / 00:01:00

Creates and saves the record during measurement. There is a detailed description in the [Recorder](#) chapter.

# Route

The route module is used for route measurements. DDS software is required for creation of route measurement structure. For more details see also DDS manual – all functions are described there.

## Loading of the route to the instrument

Open the database in DDS which you want create the route from. Open the instrument window (**Route – VA5 Pro**).

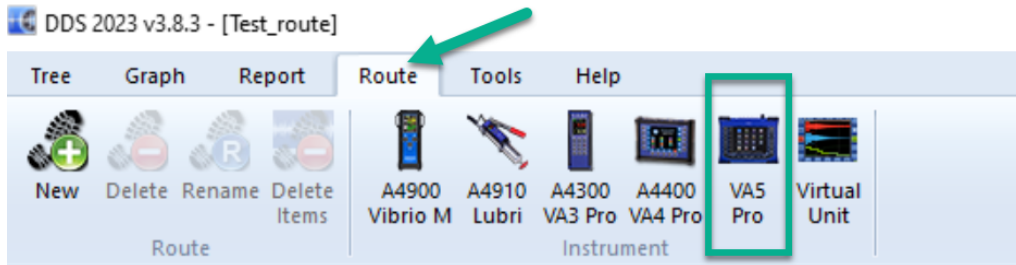

The route window appears (left bottom corner).

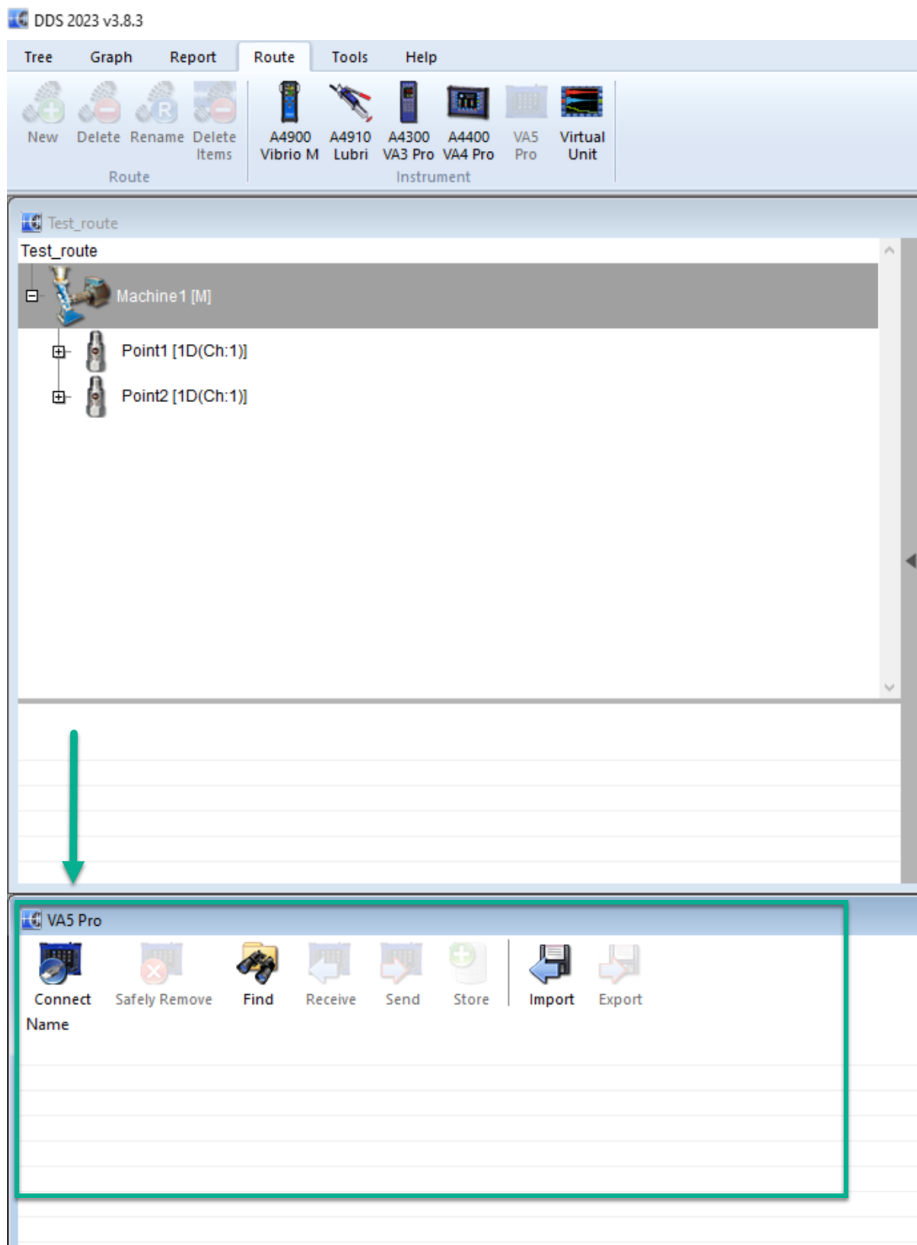

Connect the instrument with **USB** cable.

Press the **Connect** button. The message window with connection process description should appear.

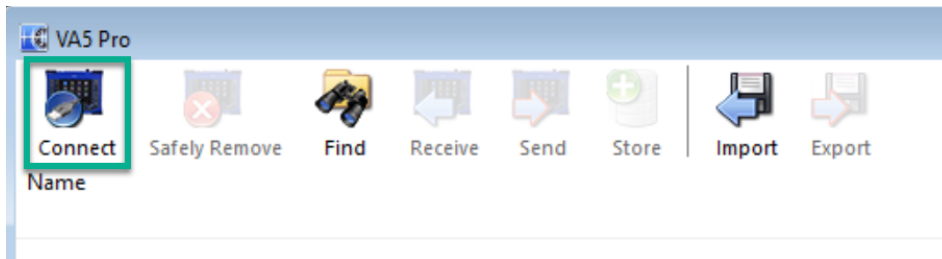

The list of data saved in the instrument appears.

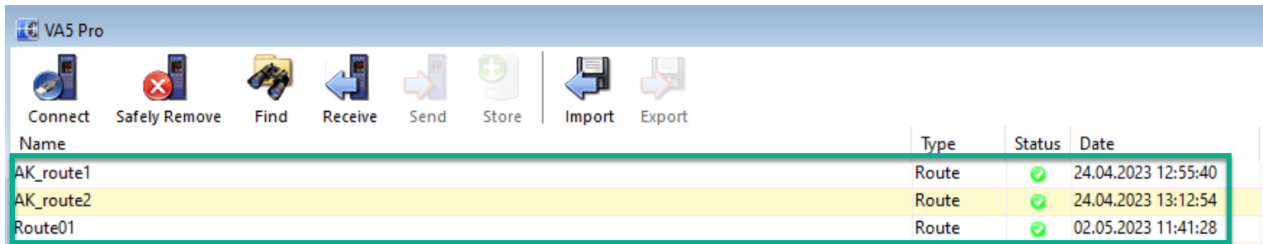

Move the required points from the DDS tree to the route window (use mouse **Drag and Drop**).

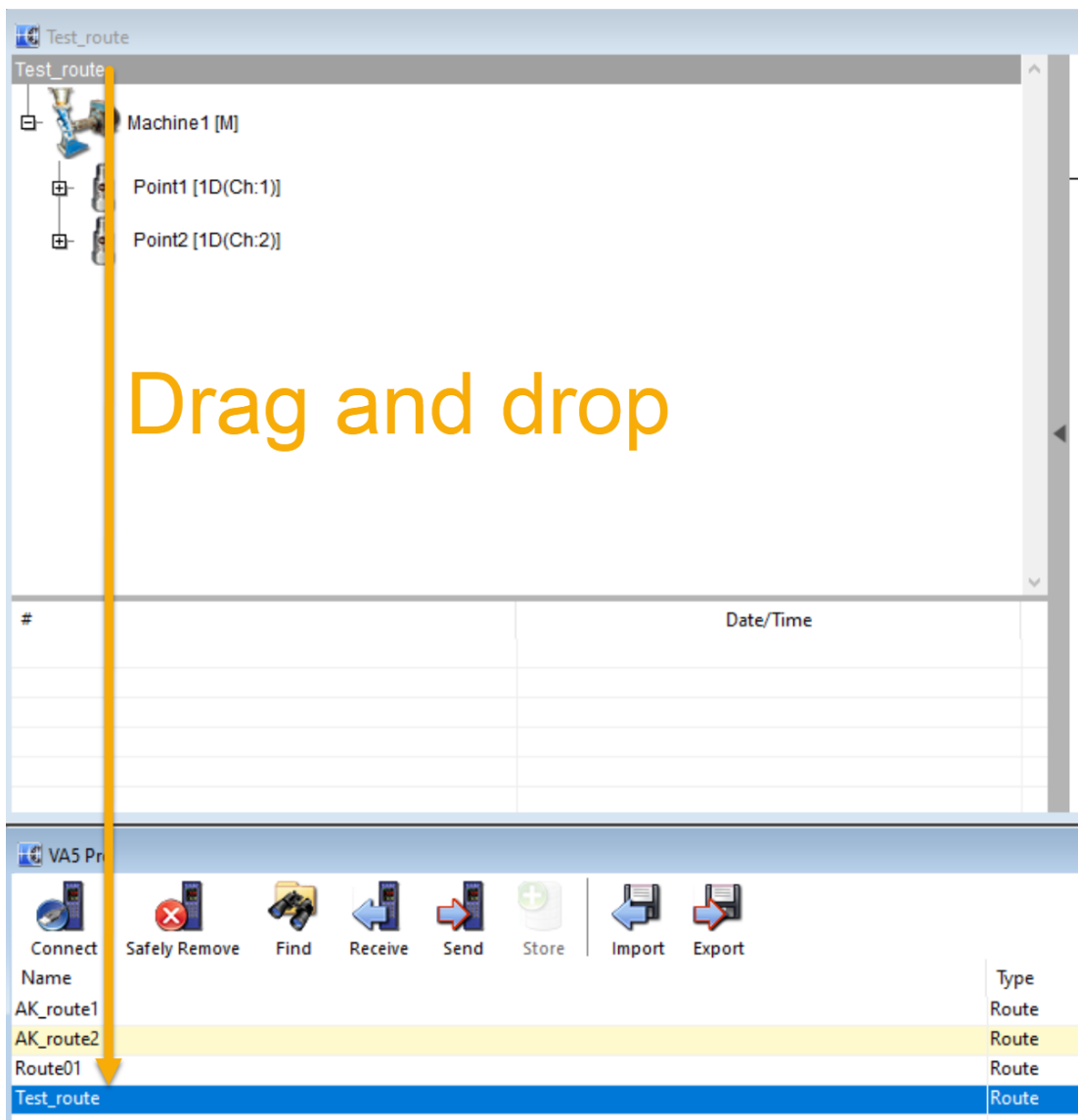

Press the **Send** button. The route data will be loaded from the computer to the instrument.

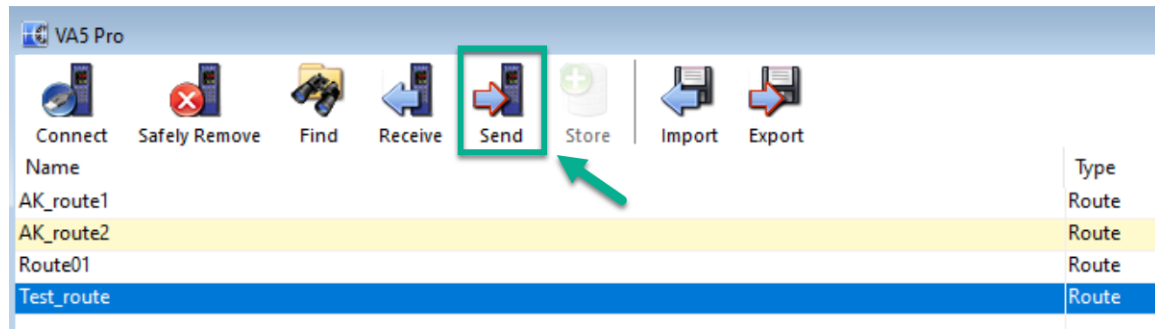

**Note!** Keep in mind that the structure of tree is changed when you create a route from a part of a tree in DDS. This is because the VA5 instrument strictly requires the tree with the following structure *Route - Machine - Measuring Point - Measurement*. If there are more items in a DDS tree in a path between these items, the names of such items are combined together (like in this example *Turbo Generator/Fans/Fan 1* or *Motor/L1RV* etc.). If the item name in a route tree is longer than 45 characters, DDS tries to truncate such names. To avoid this, we recommend using shortcuts in tree items (in this case "Turbo Generator" should be "TG").

### Route creation in VA5 device

The route tree can also be created in the instrument. When you want to transfer this route to DDS you must prepare a database for it. More information can be found in DDS manual.

Go to **Route** module on main VA5 screen. You can see the list of routes in the device.

Click on **Route** (in the left bottom corner), choose '**New**' and enter route name.

### Route Tree

Routes are similar to *L1 Projects* in the [Analyzer](#) module. After opening the module, import of routes from the *VA5\_DISC* is done. Then, a **Route List** of all routes in the instrument is displayed. The date and time of the last modification of the selected item is displayed in the top right corner.

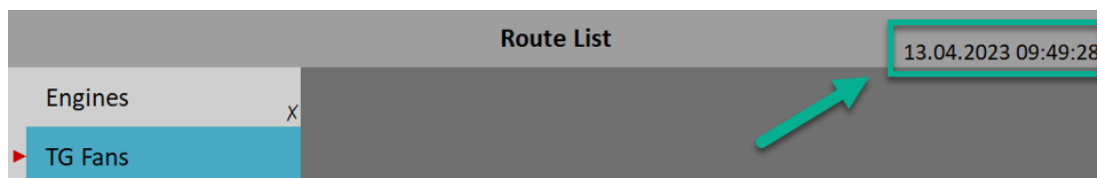

**Note!** Routes that are only modified on internal disk and have not yet been exported to the [VA5\\_DISC](#) are marked with a cross symbol (X).

Select one route and push *Enter* or tap twice. A route tree is loaded and a **Machine List** of machines in the opened route is displayed.



The opened route's name is marked in the status bar by bold font. The list type is below the name, this indicates the current tree level.

Walking through the tree is straightforward. Use up and down arrows to select an item. *Enter*, right arrow or double tap opens an item and its members are displayed in a new list. *Escape* or left arrow returns you one level higher. If a *Machine List* is opened, *Escape* closes the route.

Open any machine. A **Point List** is displayed.

| TG Fans/Fan1 |  |
|--------------|--|
| Point List   |  |
| ▶ Motor/B1RV | 1ch<br>ISO RMS<br>L: 2.20 mm/s R: 2.00 mm/s<br>BEARING RMS<br>L: 0.849 g R: 1.00 g |
| Motor/B1RH   | 1ch  |
| Motor/B2RV   | 1ch  |
| Motor/B2RH   | 1ch  |
| Triax        | 3ch  |

An item's complete path is displayed in status bar by bold font. Long names could be shortened.

The number of AC channels for each point is displayed behind the point name.

When no data has been taken yet, the *Last (L)* and *reference (R)* values of overall measurements within the selected point may be displayed next to the point list. These values are initially taken from the database and are stored together with the route. The last value is always changed when data is saved, while the reference value remains unchanged.

After taking a measurement, the measured values of overall measurements are displayed together with their difference in percent from the previous (L) and reference (R) values.

**Note!** If you decide to clear the data from the route in device, you can do it with "Clear data" option. Data measured will be deleted, but the LAST measured value will be still kept – for comparison with the new measured data in route. If you want to have route completely without data (and without this last value), it is needed to import it again from DDS without data.

| TG Fans/Fan1   |   |
|----------------|---|
| Point List     |   |
| ▶ ✓ Motor/B1RV | 1ch<br>ISO RMS<br>2.14 mm/s [L-3%, R+7%]<br>BEARING RMS<br>0.912 g [L+8%, R-9%] |
| Motor/B1RH     | 1ch   |
| Motor/B2RV     | 1ch   |
| Motor/B2RH     | 1ch   |
| Triax          | 3ch   |

You may start a measurement process of the selected point by pressing *Enter*. However, in the Route module, you may walk the tree down to a particular measurement level. Thus, you may work with any single measurement independently, e.g., you may measure only one measurement in the point. Open any measurement by pushing the right button or double tap. In the **Meas List**, an index of a channel is before a name.

| TG Fans/Fan1/Motor/B1RV |                                      |
|-------------------------|--------------------------------------|
| Meas List               |                                      |
| ▶ 1.ISO RMS             | ISO RMS<br>L: 2.20 mm/s R: 2.00 mm/s |
| 1.BEARING RMS           |                                      |
| 1.ISO TIME              |                                      |
| 1.ISO SPECTRUM          |                                      |

If *Point List* or *Meas List* are displayed, the *Enter* button starts the measuring process on the selected item. If you want to open the graphs window and you don't want to start the measurement immediately, use the **Point (or Meas) / View Actual** menu item. **Point (or Meas) / View Trends** opens trends of the selected item.

### QR

This feature will definitely make your route measurements easier – each QR code identifies one machine in a route. After you scan it, the instrument opens the right machine.

**Note!** QR codes are generated in DDS software. More information can be found in DDS manual. It is not the part of this VA5 manual.

How to use this feature is described in following steps.

Go to Route module in your VA5 device. Choose the route which you are going to measure in the route list.

Now you can see the 'QR' button. Click on it.

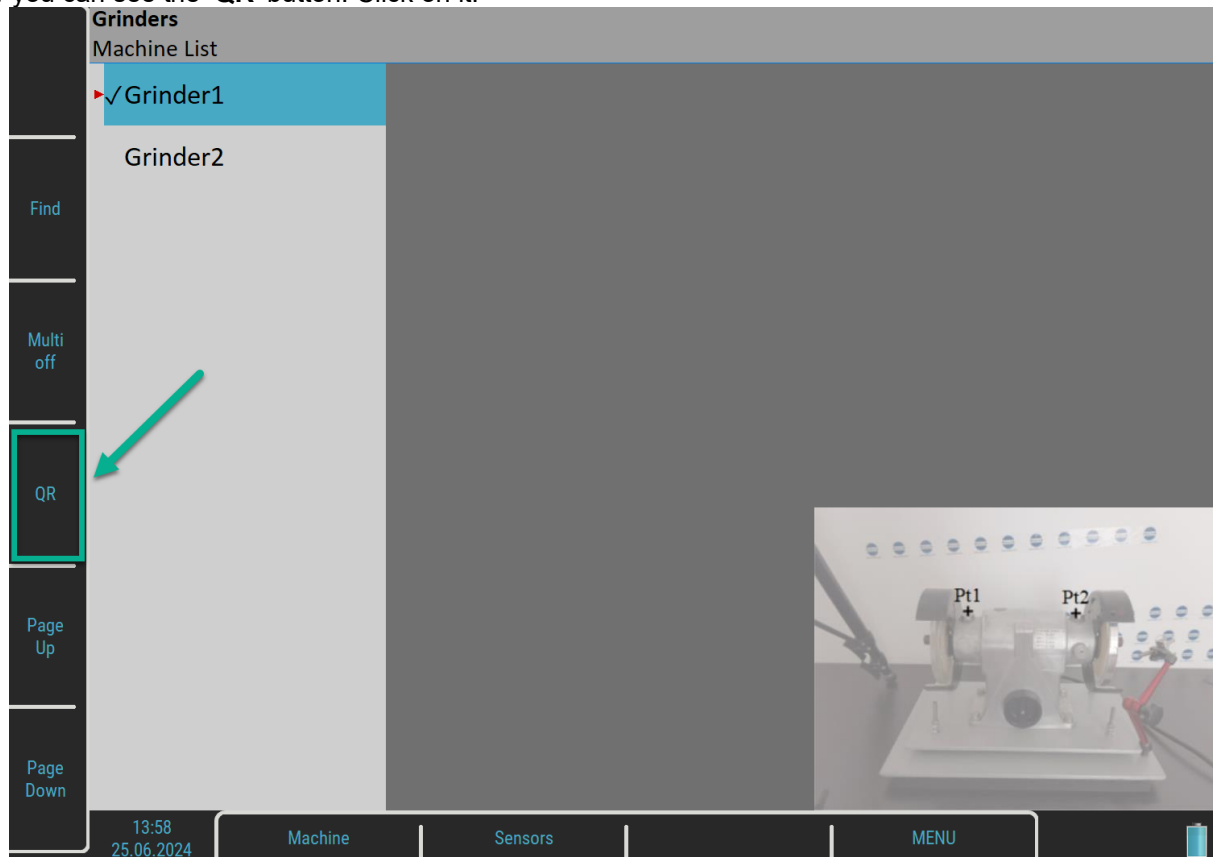

You can see the 'Loading' note on the screen.

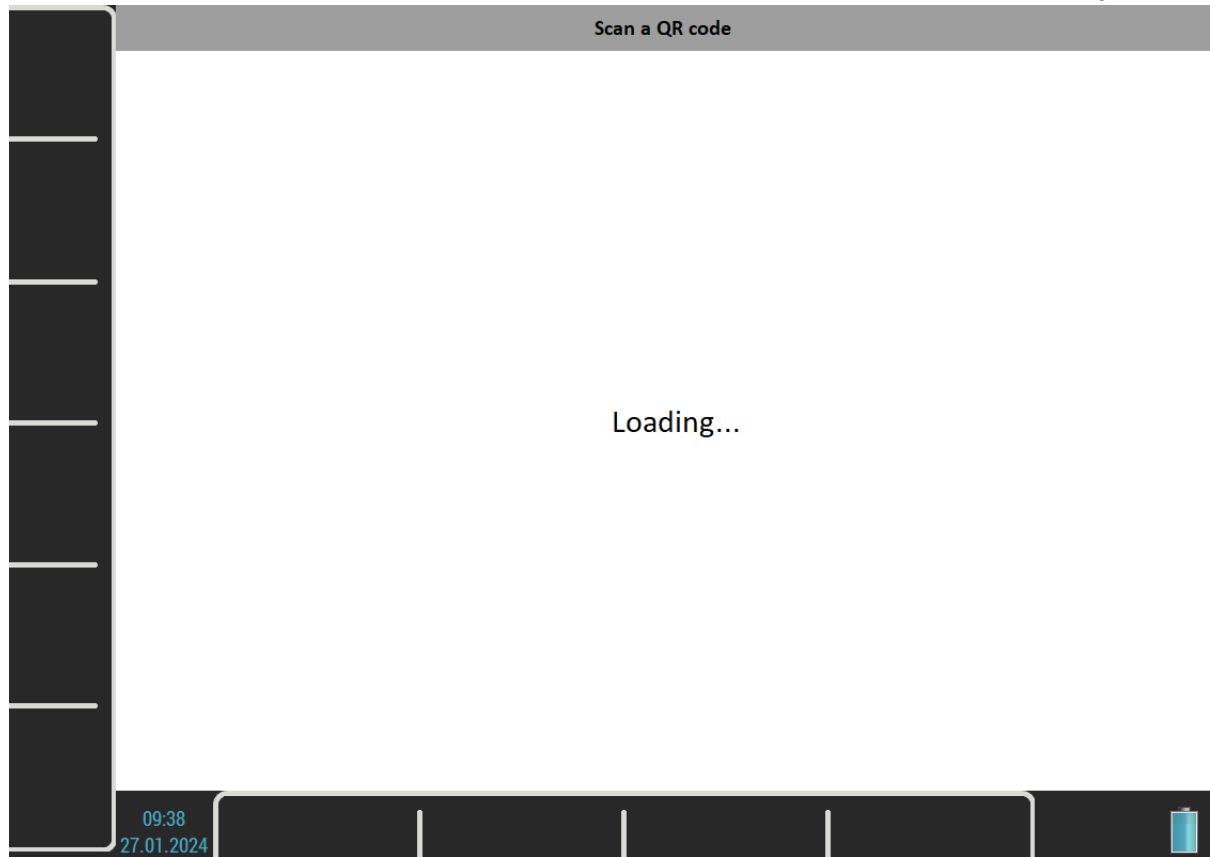

Once you can see through the VA5 camera, you can direct it to the QR code on the machine and it will be scanned with VA5 device.

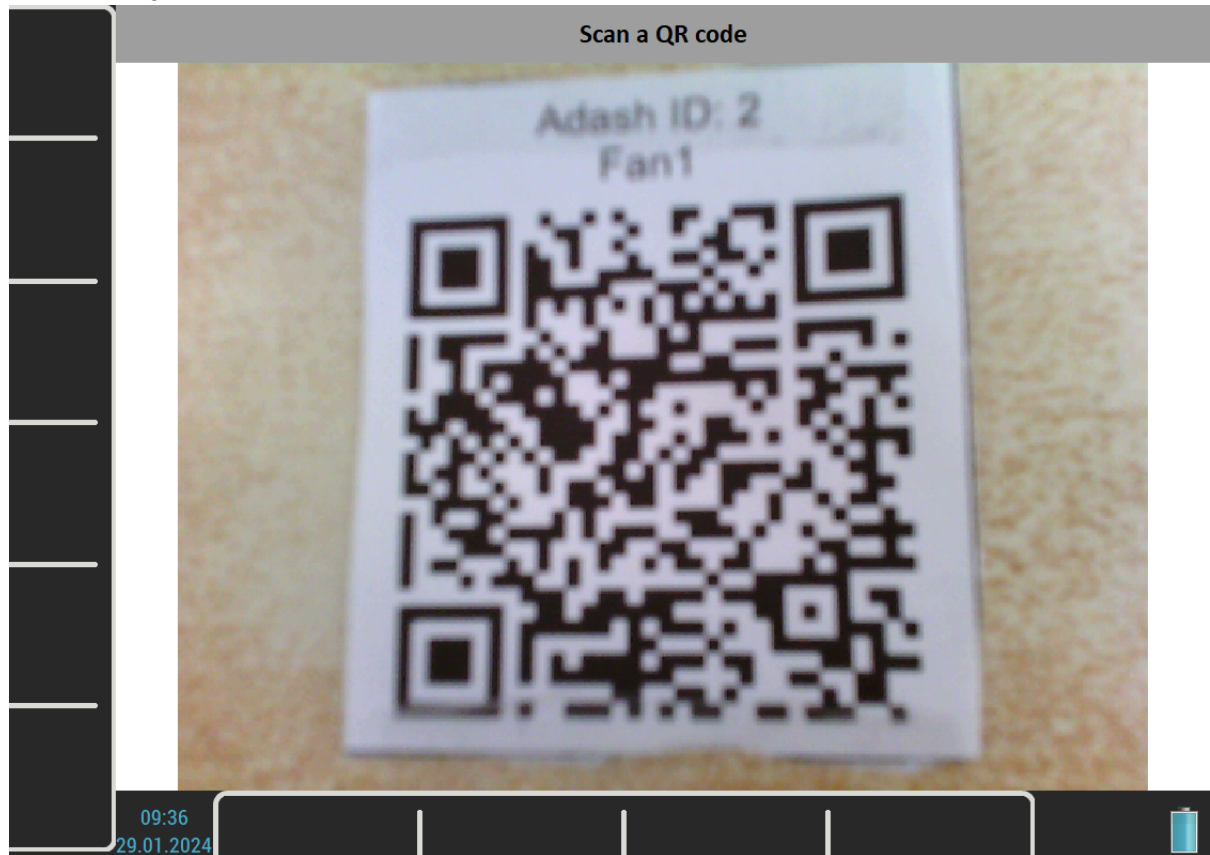

After the QR code is read, you can see the loaded list of measurement points on the machine from the particular route measurement.



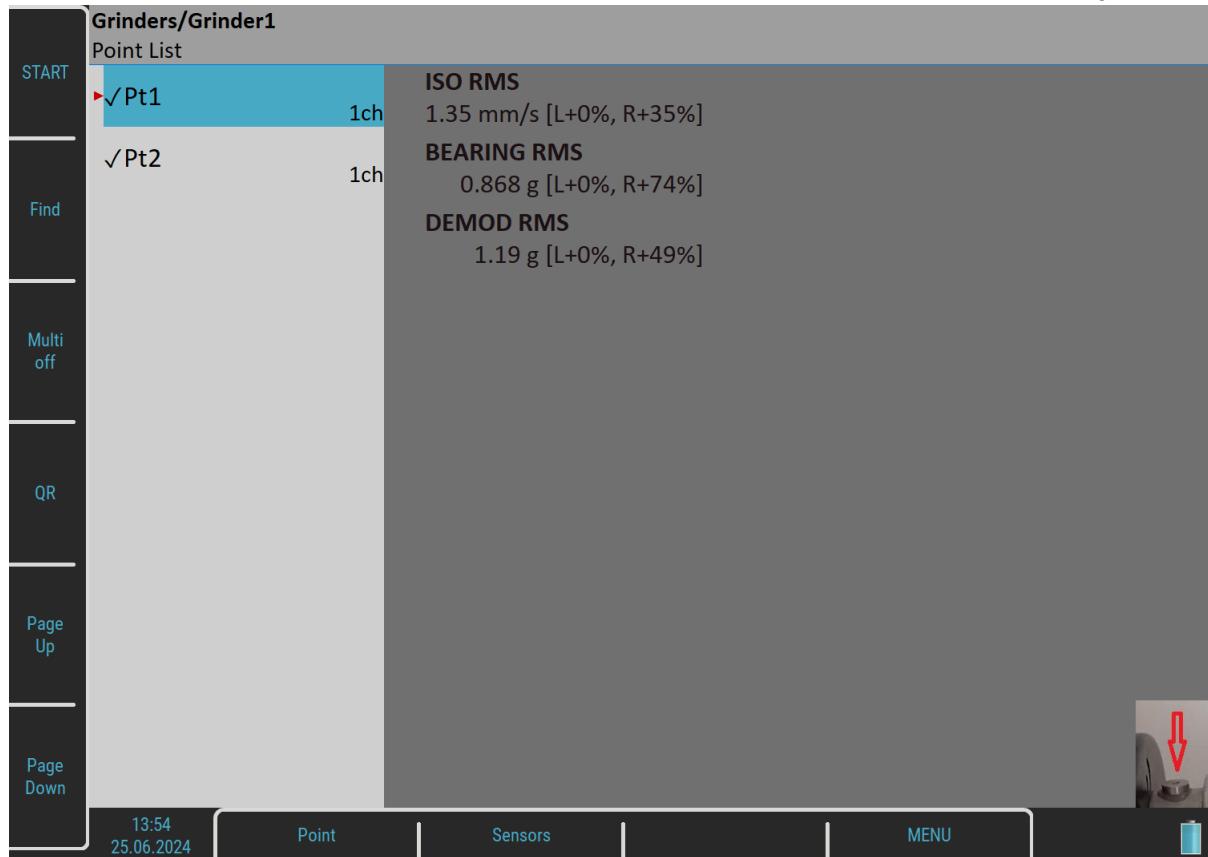

**Note!** It can happen that QR scanning will end up with an error message. The reason for it can be that you scan QR code from the different route, or that QR code structure is incompatible.

### **Route images**

You can add the picture to particular parts in the tree. You can add the image of the machine and also you can add picture for particular measurement points on this machine. This image can be added in DDS software (see how to do it in DDS manual). These images are visible in the VA5 device once you click through the tree. The image is shown always in the right bottom corner (see pictures below – 1. machine image, 2. particular points).

**Grinders**  
Machine List

1. ✓Grinder1

Grinder2

Find

Multi off

QR

Page Up

Page Down

13:58  
25.06.2024

Machine

Sensors

MENU

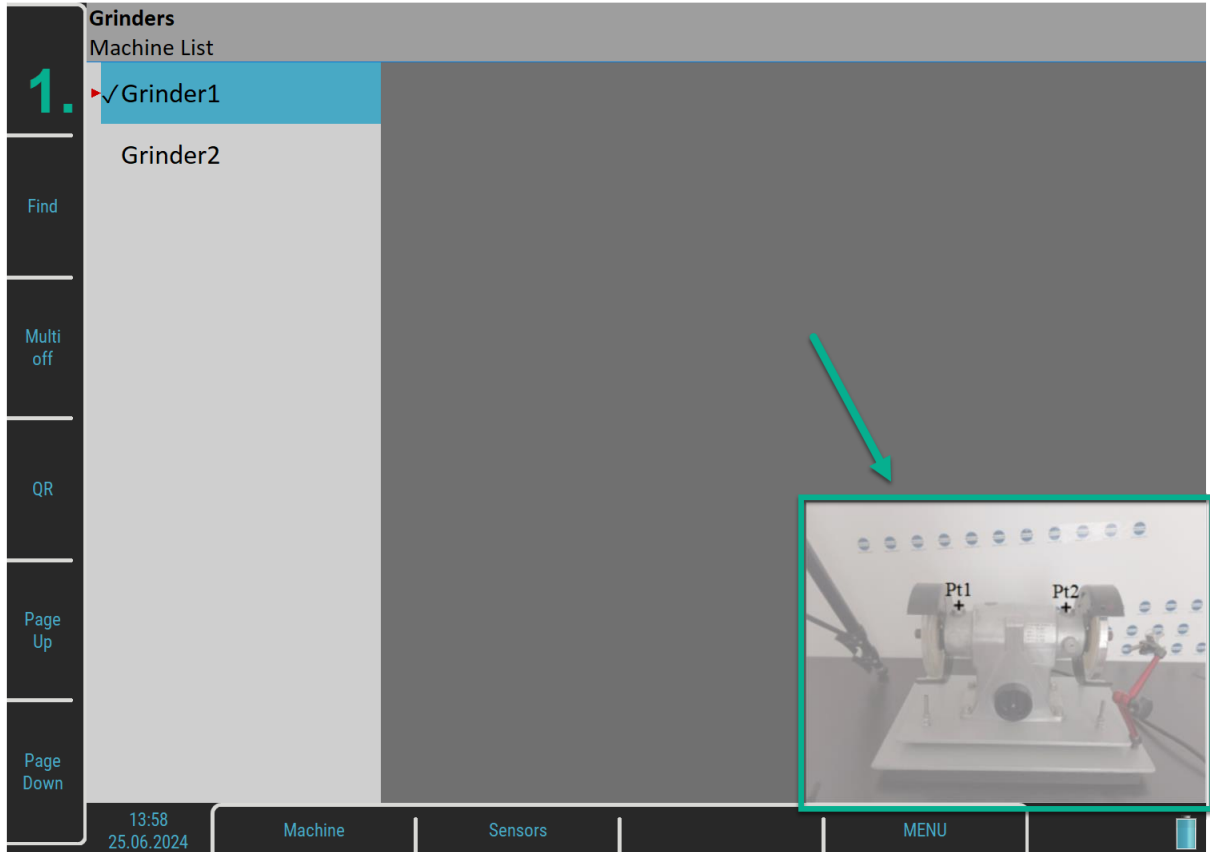

**Grinders/Grinder1**  
Point List

START 2. ✓Pt1 1ch

ISO RMS  
1.35 mm/s [L+0%, R+35%]

✓Pt2 1ch

BEARING RMS  
0.868 g [L+0%, R+74%]

DEMODO RMS  
1.19 g [L+0%, R+49%]

Find

Multi off

QR

Page Up

Page Down

14:00  
25.06.2024

Point

Sensors

MENU

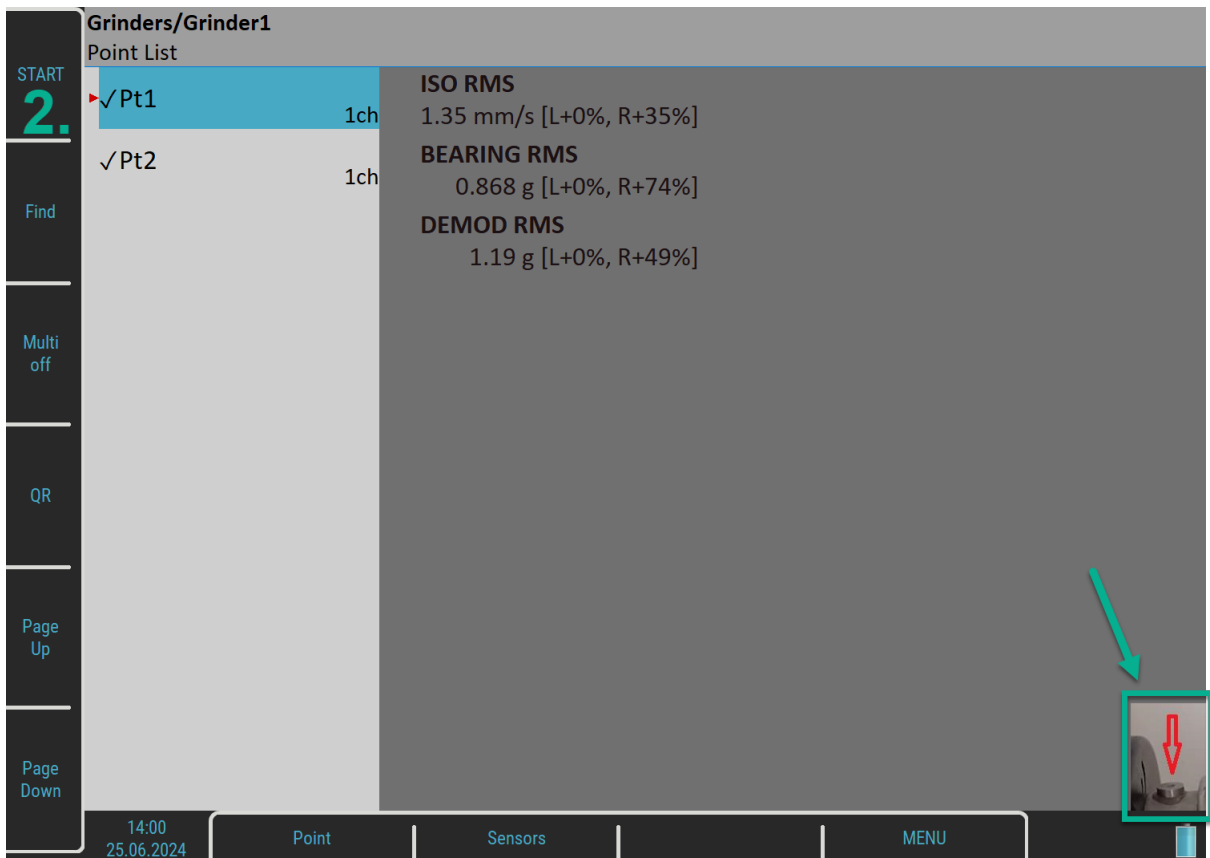

**Note!** If the image is added only to the machine and not for the measurement points under it, the image is “inherited” from the machine level. It means, that you can see the machine image also when you click through measurement points (see below – the picture for points is the same as for the machine).

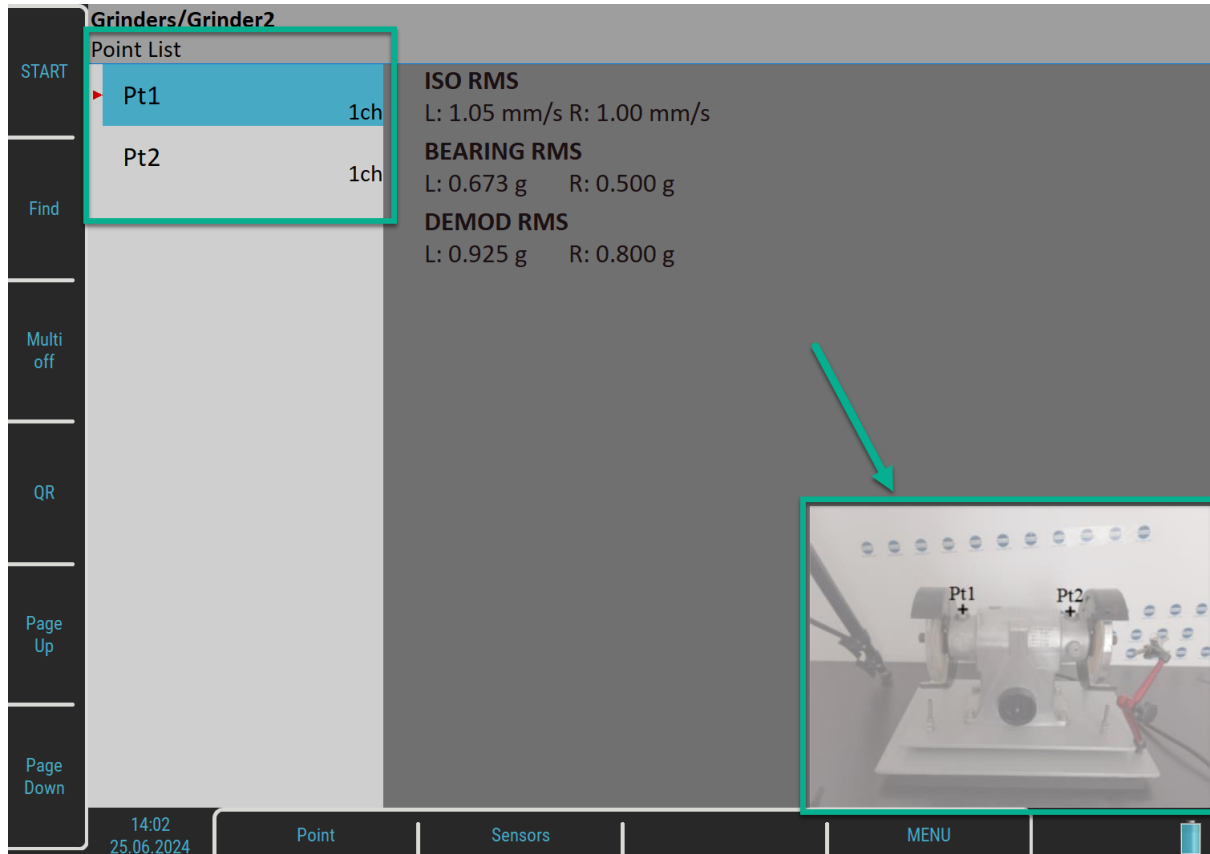

## Sensors Check

Each point in the route contains the sensor setting, which is defined in DDS. The instrument also contains the sensors setting. Both settings are compared for each point while opening graphs window. When the sensors settings are not equal, the “**Used sensor**” message appears.

Used Sensor  
on AC1: 100 mV / g, ICP on

Connect the requested sensor and confirm the message. Sensors setting will be stored in the instrument automatically and you don't need to set it. In case the “Used Sensor” message appears, measurement will not be started automatically. If you need to change any parameter you can do it in the [Sensors](#) menu.

There is a different approach for sensors with a [Name](#) defined. If one of the compared sensors has the name defined, then only names are compared. If names are the same, the sensors are supposed to be equal regardless of other parameters' setup and no parameters are redefined in the instrument. E.g., you may use it to setup different sensitivity of a sensor. In case the names differ, a “Used Sensors” message will appear with the sensor's name.

Used Sensor  
ACC100 on AC1: 100 mV / g, ICP on

When you first open a point in Route module the “Used Sensor” message appears even if the sensors are the same just to inform you which sensor you have currently defined.

You can turn the sensors check off and on again in [Global Settings](#) / [Check Route Sensors](#).

### Measurement process

Push the *Enter* button to begin the measurement process. All defined measurements will be taken together. The measured data are or are not displayed on the screen depending on the [Display Route Values](#) parameter in the [Global Settings](#) menu.

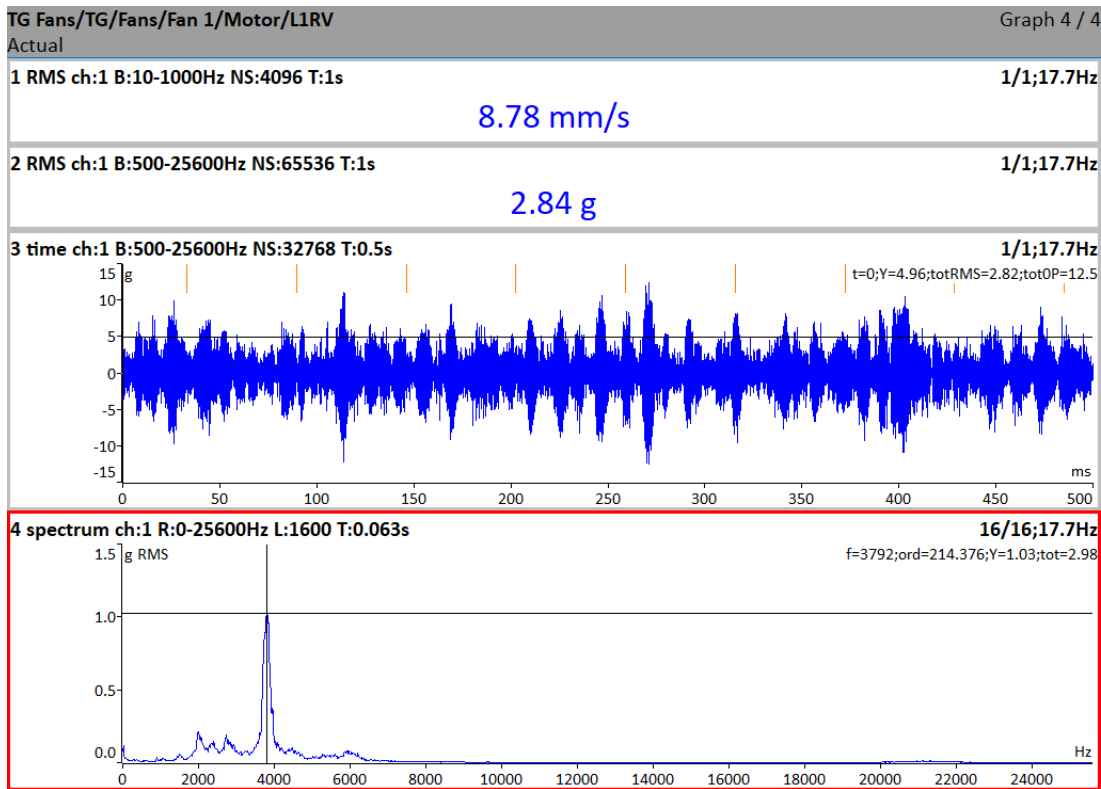

All values are automatically saved unless you set the [Route Autosave](#) parameter in the [Global Settings](#) menu to **off**.

If the [Route Auto Forward](#) parameter in the [Global Settings](#) menu is set to **on**, then the graphs window will be automatically closed after all data are saved. Otherwise, use the *Escape* to return back to the list. The measured point is labelled by the symbol √ (all defined measurement were taken). The next point in the list will be selected if all measurements are taken correctly.

| TG Fans/TG/Fans/Fan 1 |     |
|-----------------------|-----|
| Point List            |     |
| √ Motor/L1RV          | 1ch |
| ▶ Motor/L1RH          | 1ch |
| Motor/L2RV            | 1ch |
| Motor/L2RH            | 1ch |
| Triax                 | 3ch |

### Route Meas Mode

In DDS measurement point properties / Other tab, you may set the *Route Meas Mode* property.

If **Single** is set, only one reading is taken and the measurement process is stopped.

If **Retrig** is set, the measurement process runs until the user presses the *Stop* button. No values are saved during the measurement. For both of these modes, it depends on the [Global Settings](#) / [Route Autosave](#), whether the reading after finishing the measurement is saved or not.

If **Continual Saving** is set, the measurement process also runs until the user presses the *Stop* button. Moreover, all readings are saved regardless of whether the [Route Autosave](#) parameter is set or not. It is designed for short series of measured values. For example, you want to measure one elevator run or one run of a press machine. See more details in *DDS manual*.

Trend without continual saving:

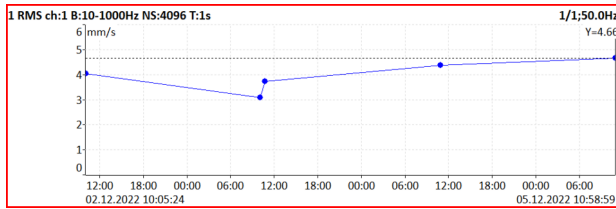

Trend using continual saving:

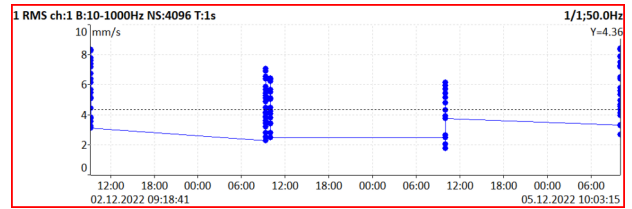

In case of *Continual Saving*, the *Measuring* indicator in status bar changes into *Continual Saving* and contains additional information, the number of saved readings (15) and the free memory size (30.2GB).

Graph 1 / 1  
Continual Saving;RT;15;30.2GB

### Route Status

All items in the route tree (points, machines or even whole routes) can be marked by a status symbol.

- ✓ all measurements of the route tree item were correctly taken.
- ! error during measurement process.
- only some measurements of the route item were taken

| TG Fans/TG/Fans/Fan 1 |     |
|-----------------------|-----|
| Point List            |     |
| ✓ Motor/L1RV          | 1ch |
| ! Motor/L1RH          | 1ch |
| · Motor/L2RV          | 1ch |
| · Motor/L2RH          | 1ch |
| ▶ Triax               | 3ch |

**Note!** The symbol can be cleared using *Route / Clear Checks*. This action does not erase any data. It can be useful when you want to take the route again without transferring data into the database.

### Last and reference values

The last measured and reference values can be downloaded from a database inside a route. In DDS, you'll be asked whether to store reference values during route creation. Last values are stored automatically by default (this can be turned off). See the DDS manual for more details.

For overall measurement, the last (L) and reference (R) values are displayed on the left side of the graph. The reference value is also displayed like a line in the trend view.

The differences in percentage from the previous (L) and reference (R) values are displayed behind the measured value.

The last value is always changed when data is saved, while the reference value remains unchanged.

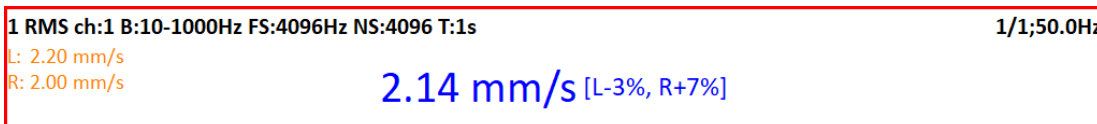

Reference spectrum is displayed together with measured spectrum in the same graph.

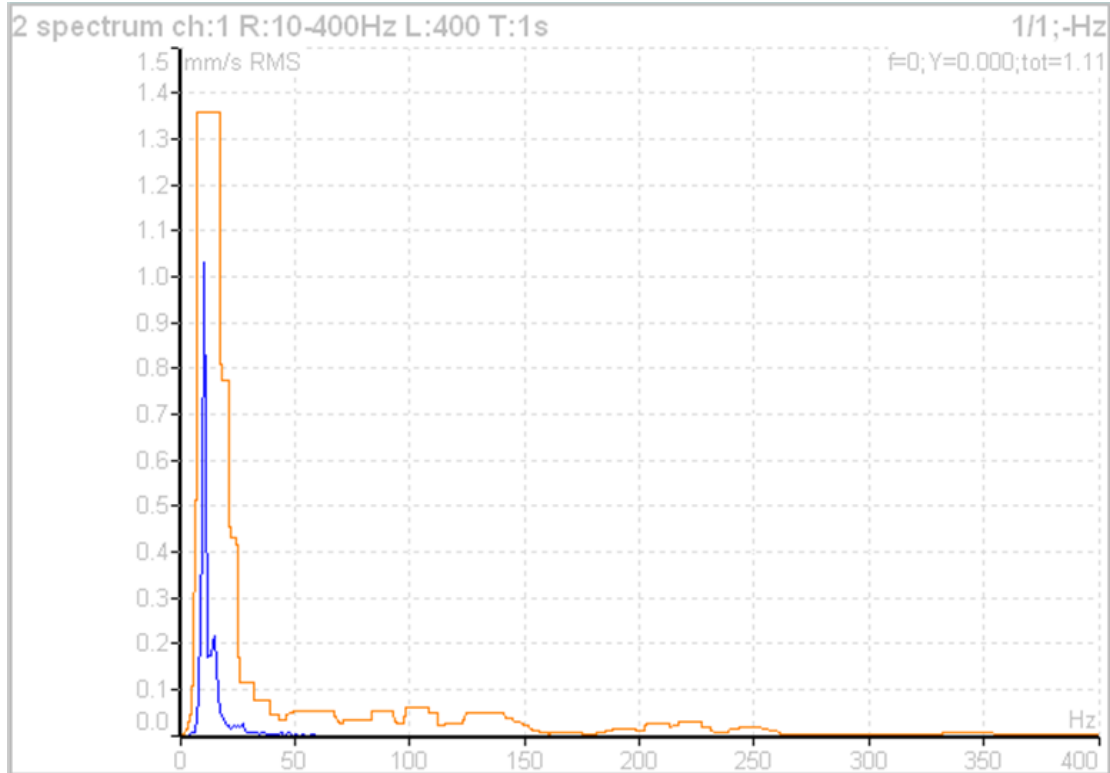

## Manual Entry

The route may contain the measurements which have to be entered manually (for example, temperatures read from analogue display). These measurements are defined by the **Manual Entry** choice in DDS. An entry dialog is displayed for all manual entries during measurement process initialization. These values are saved together with the measured values.

Enter value [°C]  
Temp1 (Graph1)

## Notes

You can attach short text notes to a tree item in the route. The same is available in the Analyzer and Runup modules.

Push the left menu button (named as *Route*, *Machine* or *Point*, depending on which level is currently displayed). Select the **Notes** item. The list of existing notes for the selected item appears. It is empty when no note has been created yet.

Notes  
TG Fans/TG/Fans/Fan 1/Motor/L1RV

Empty

Push the **Add** button to create a new note. New window appears. You can directly type the note in the upper half area. The User notes list is displayed at the bottom. Several ways how to create a new note exist.

- Select one note from User notes list and press **Select**. The selected note is copied to the upper area.
- Push the **User/Factory** button to change the User notes to Factory notes or back. Then choose the note from the list and press **Select**.

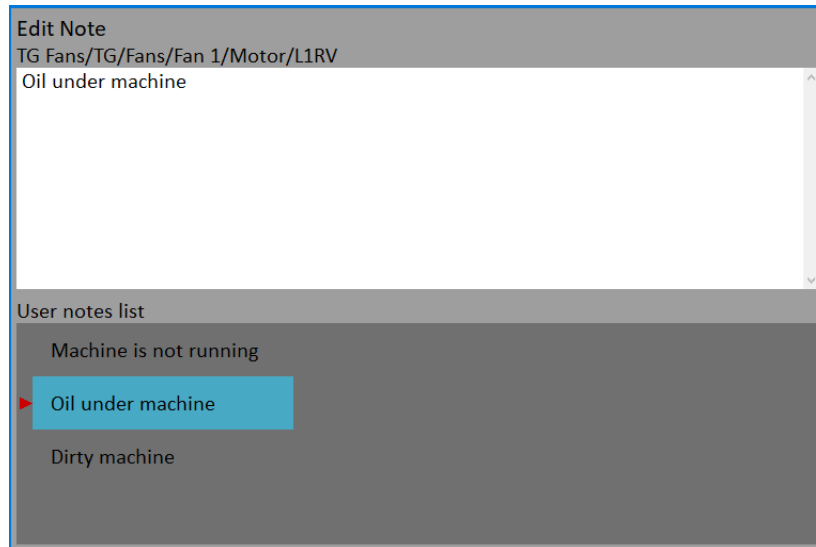

- If you want to enter your own text, then press the **Edit Text** button. The cursor appears in the upper area and you can enter the required note. Push **Escape** to return back to the selection of User/Factory note.

If the note is done, press the **Escape** button. You return back to the list of all notes for the selected point.

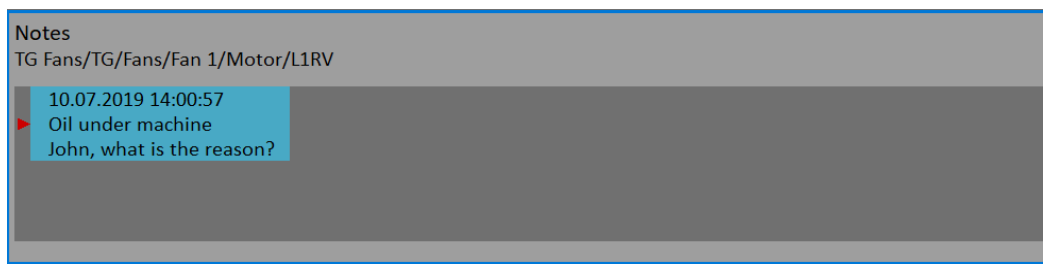

You can also edit any defined note. Press the **Enter** or the **Edit** button when the Notes list is opened. The selected note opens for editing.

Press the **Delete** button to delete the selected note.

Push **Escape** to leave the list of notes. The **N** letter appears behind the point name in the list.

**Attention!** The notes created at a measurement point (or set) after performing a measurement at a point are automatically included into csv header during export to csv (see [Analyzer](#) / [Meas Menu](#) / [Export to csv](#)).

## Speed in the Route

There are various ways how to get the speed and transfer it to DDS. The ways are described here in the order from the lowest priority to the highest priority.

### Speed entered in DDS

The **Default Speed** can be set in DDS as a machine parameter. This value is sent to the instrument and it is used in place of the tachometer value. The three options of **Default Speed** are available for the machine item.

- **Entered value** – the value is sent to the instrument. The value is used only for FASIT measurement. If the value is entered, then no speed detection is used.
- **Detected** – option runs speed detection before measurement (see the [Speed detection](#) chapter).
- **Manually Entered** – opens “**Enter the speed**” dialog, where you enter the value, before the measurement process

The current entered or detected speed value (if defined) is displayed in the information panel at the right (if the measurement is not in progress).

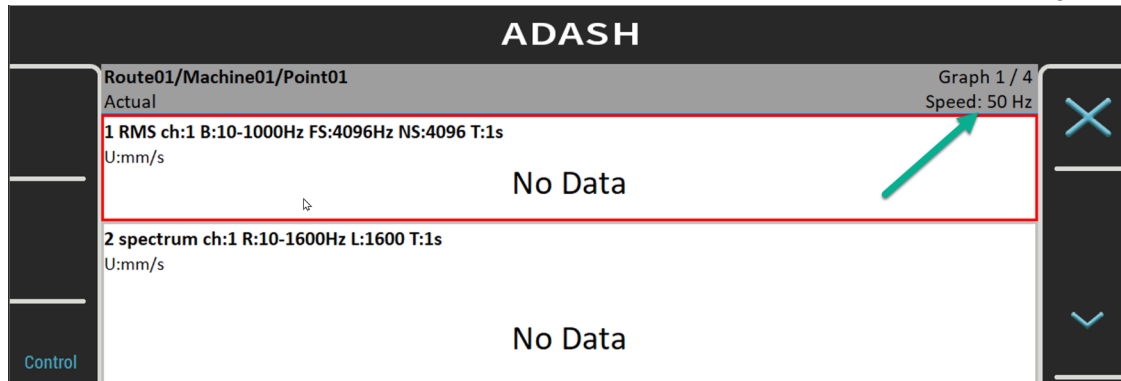

**Note!** Detected or manually entered speed is valid for the whole machine. Unless you close the machine item, the same speed value is used.

### Entered Speed

You can manually enter the speed value which is then used instead of a tacho measurement. Push the left menu button (named as *Route*, *Machine* or *Point*, depending which level is currently displayed). Select the **Enter Speed** item. A dialog will open. Enter the value and confirm.

Enter the speed [Hz]

Warning! If tacho sensor is used then tacho speed has priority.

The entered speed value will be saved to all following readings. It is saved to the same position in the data head as the speed measured by tacho. If the speed is manually entered and also measured by tacho, then the tacho is prioritized and saved.

The manually entered speed is displayed on the right side at the top of the screen with the word "Speed:"

Speed: 50 Hz

The *entered speed* can be cancelled using the **Cancel Speed** item in the same menu. The *entered speed* is automatically closed when closing a machine.

**Note!** Entered speed is prioritized above the speed entered in DDS.

### Measured Speed

If the speed is measured by a tacho probe, it is always saved with data regardless of them having been already defined using one of the previous ways or not.

### Linear speed

You can enter a speed to VA5 in Hz (standard, see the chapter above [Speed in the Route](#)) or you can choose to enter a linear speed instead. This is new option available from VA5 firmware version 0282. The linear speed option allows you to enter the speed value in displacement units – it means you don't need to enter the speed value in Hz, but it is possible to enter speed value in m/min.

Typical example of the machines which can use this feature is the paper mills machines.

Setting of the linear speed is done in DDS software. It is not set directly in VA5 device. For more information, please see DDS manual.

**Note!** Keep in mind, that if any of the machines has roller diameter defined in DDS and this part of the tree is sent to VA5 device, you will be asked to enter the linear speed when you start to measure first measurement point. The window looks like this:

Enter linear speed [m/min]

Warning! If tacho sensor is used then tacho speed has priority.

This linear speed information will be used for the whole machine. You can see also the speed in Hz (this value is recalculated from the linear speed you have entered). This information is shown at the left top corner of the screen.



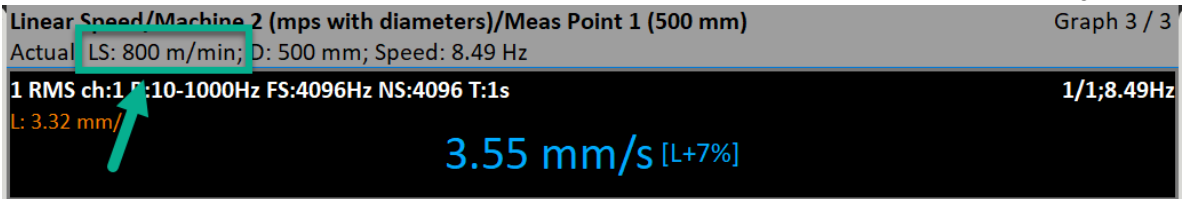

You can also enter linear speed to measurement afterwards (if you didn't enter it at the beginning of the measurement – you will not be asked again to enter the linear speed automatically). Click on “Point” button and choose option “Enter linear speed”.

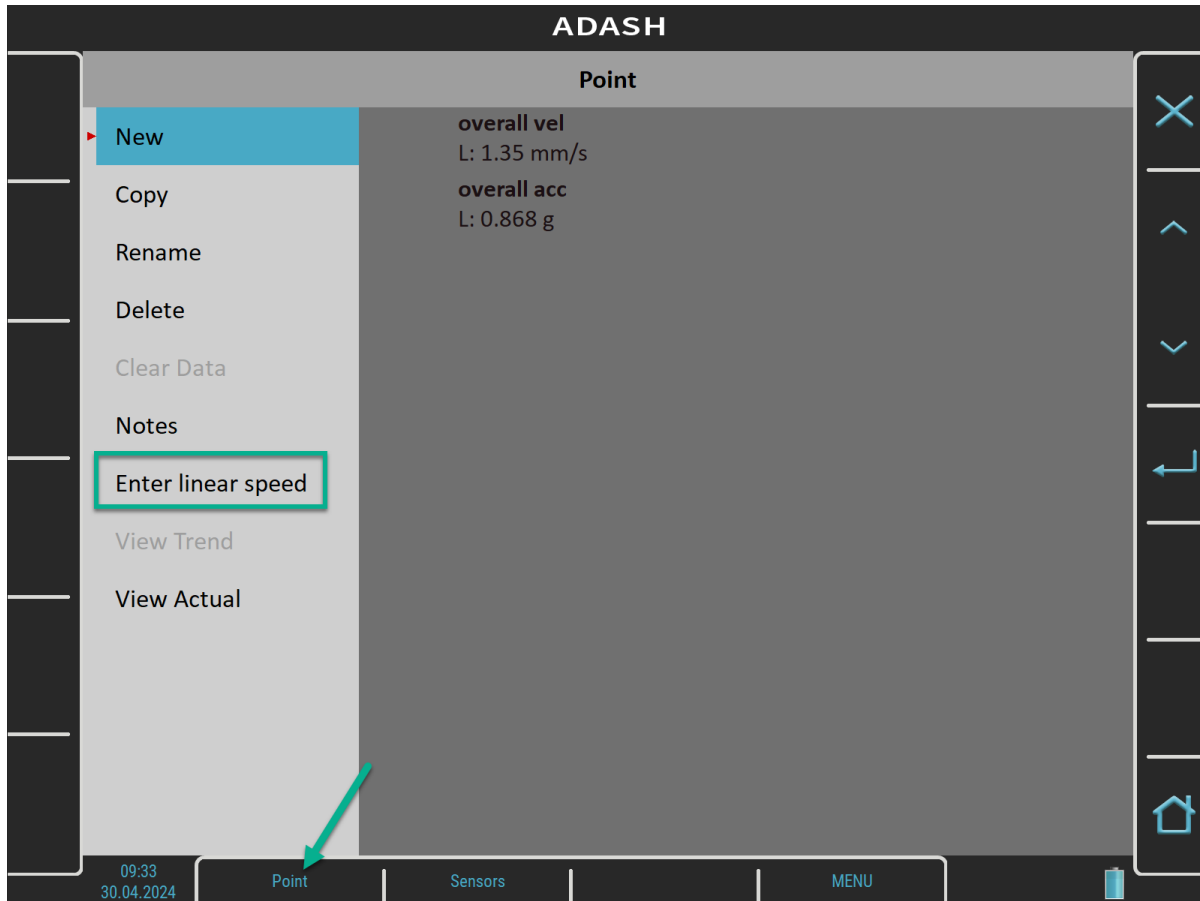

**Note!** You can see “Point” button in the screenshot above. This button can have different name based on the location where you are in the route tree (e.g. it could be named “Machine”, “Set”, etc., but you can still find linear speed setting here).

You get the same window to enter the linear speed.

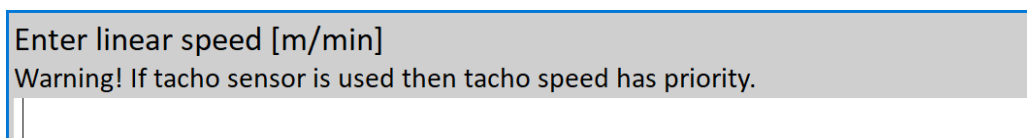

There is also an option to cancel the entered linear speed. You can do it with the same button for Point. (This option is not shown unless linear speed is entered.)

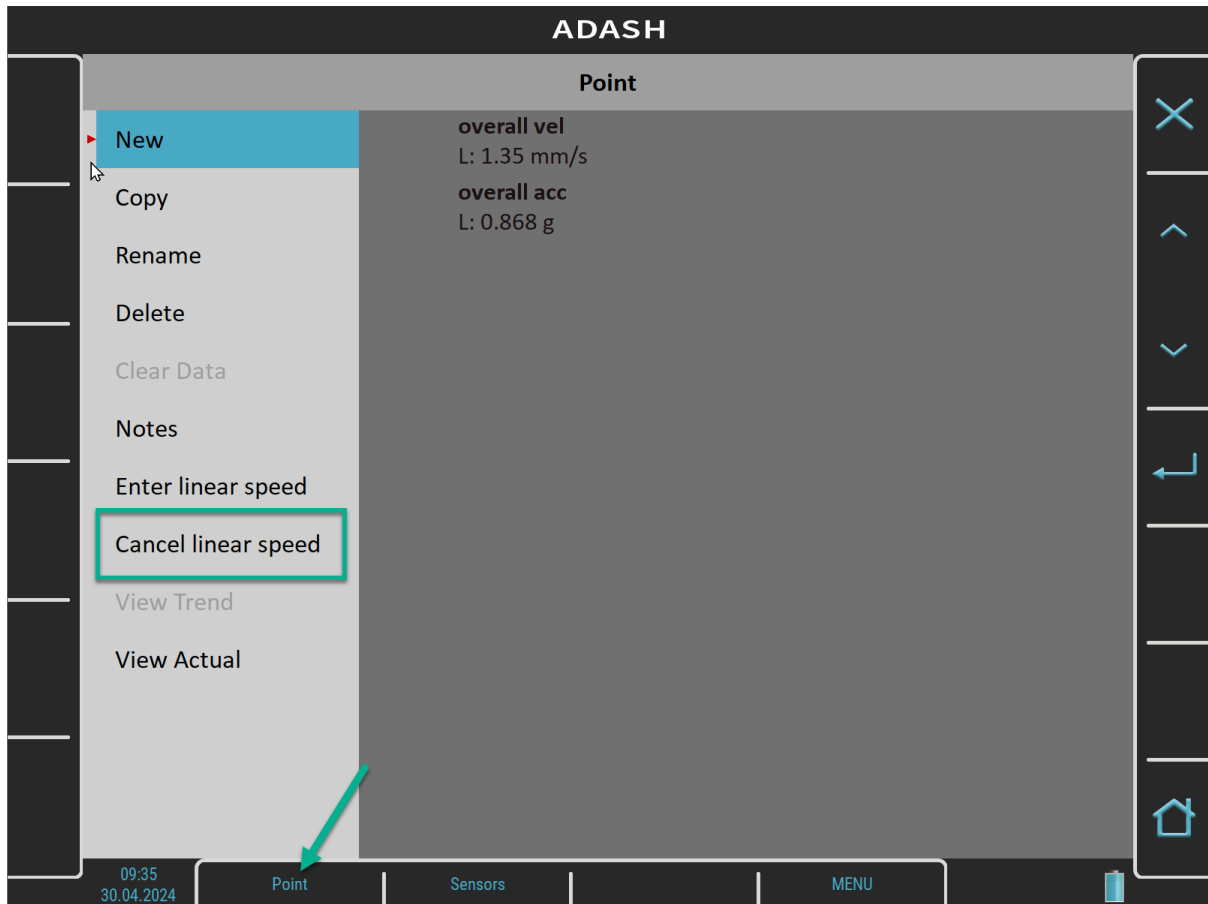

**Note!** Speed can be also left undefined.

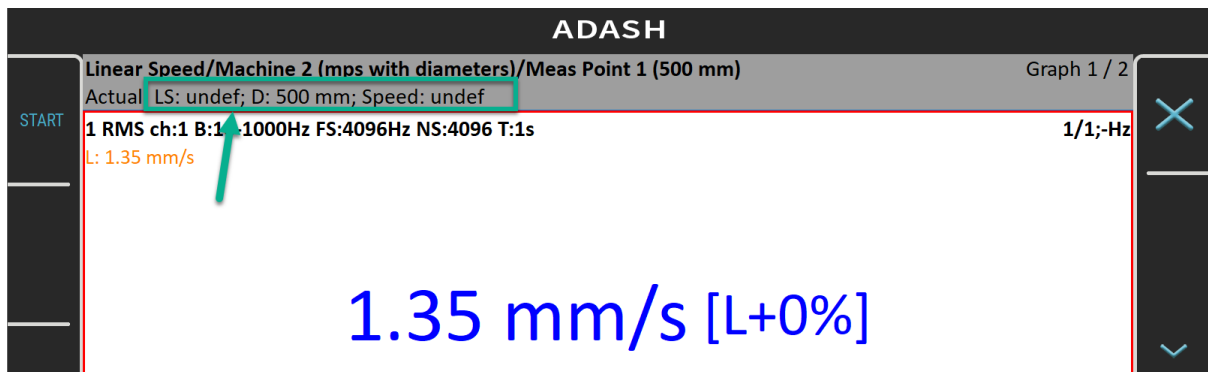

**Limits**

In DDS, you can define limit values and alarm colors (see the DDS manual to find out how to do it). For static data cells, these limits are transferred into the instrument together with the route. Exceeding the limit values is signaled during the measurement and also in trends.

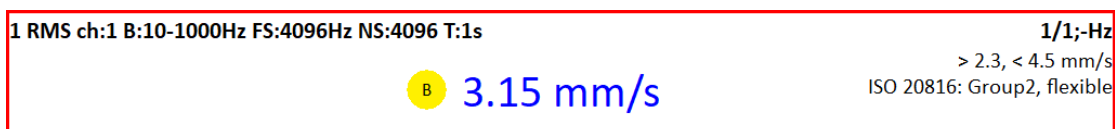

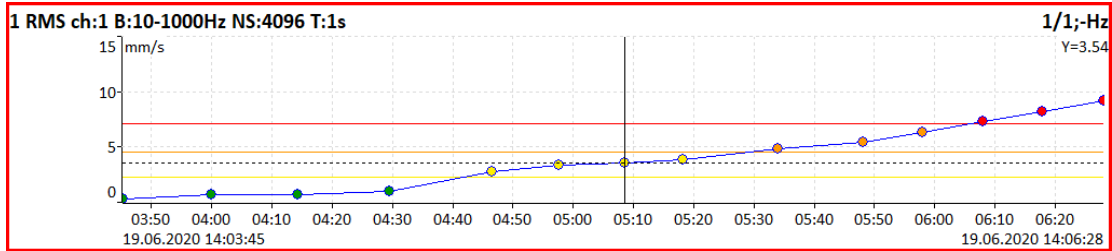

## Export to VA5\_DISC

The computer can read any data from the VA5\_DISC only. The route with measured data has to be exported to this memory before the transfer. During the route measurement, all data are saved to the VA5 hard disk only. When the route is closed the VA5 asks the user "**Export to VA5\_DISC?**" and the user selects one option. The export to the VA5\_DISC is not done automatically because the writing procedure to flash is slow. A large route export can take several minutes. That is why the user can determine when the right moment to export the route is.

You can select the route and export it manually in the menu item **Route / Export**. Furthermore, there is the option [MENU / RUN / Export All](#) which exports all unexported projects from all modules.

## **Runup**

When you need to measure Run Up or Coast Down of the machines, then you should use the Runup module. It enables the same measurements as the Analyzer module, but with controlled continual saving of values. What does it mean "controlled"? In the Analyzer mode, you can measure the set and then you have to save the measurements manually. The Runup is different. The values are automatically saved during the measurement process.

You may control the number of saved values by several ways. The setup can be done in [Trigger Settings / Runup Trigger Mode](#). The **speed** is usually used for that control and new a measurement is made when the speed changes from previous measurement by a defined value (for example, 10 RPM). Also, the **time** can be used to control that procedure. Then you can take the measurement in a defined time interval (for example, each 60 sec).

The **asap** is the next choice. It means no delay between measurements - **as soon as possible**. Be careful with such mode. You can fill the instrument's memory quickly.

The last choice is the **manual** mode.

In the Runup module, there is a number of readings and free memory space displayed in the status bar besides common information.

## **Runup Measurement**

The meaning of the *set* and also the meaning of the other terms is the same as in the Analyzer module.

We show the runup measurement on an easy example. For example, we define only one measurement in the set. The proximity sensor on channel 1 is used. The sensor must be defined in the [Sensors](#) menu. The [Runup Trigger Mode](#) is set to **speed** and the value is **1Hz**. The measurement is defined like in the picture.

| Edit Measurement |                              |
|------------------|------------------------------|
| Type             | 1x amp+phase<br>freerun,time |
| All Channels     | no                           |
| Channel          | 1                            |
| Unit             | µm                           |
| Averaging        | linear                       |
| Avg              | off                          |
| Resolution       | speed / 4                    |
| Save             |                              |

Push the *Enter* button to start the measurement process.

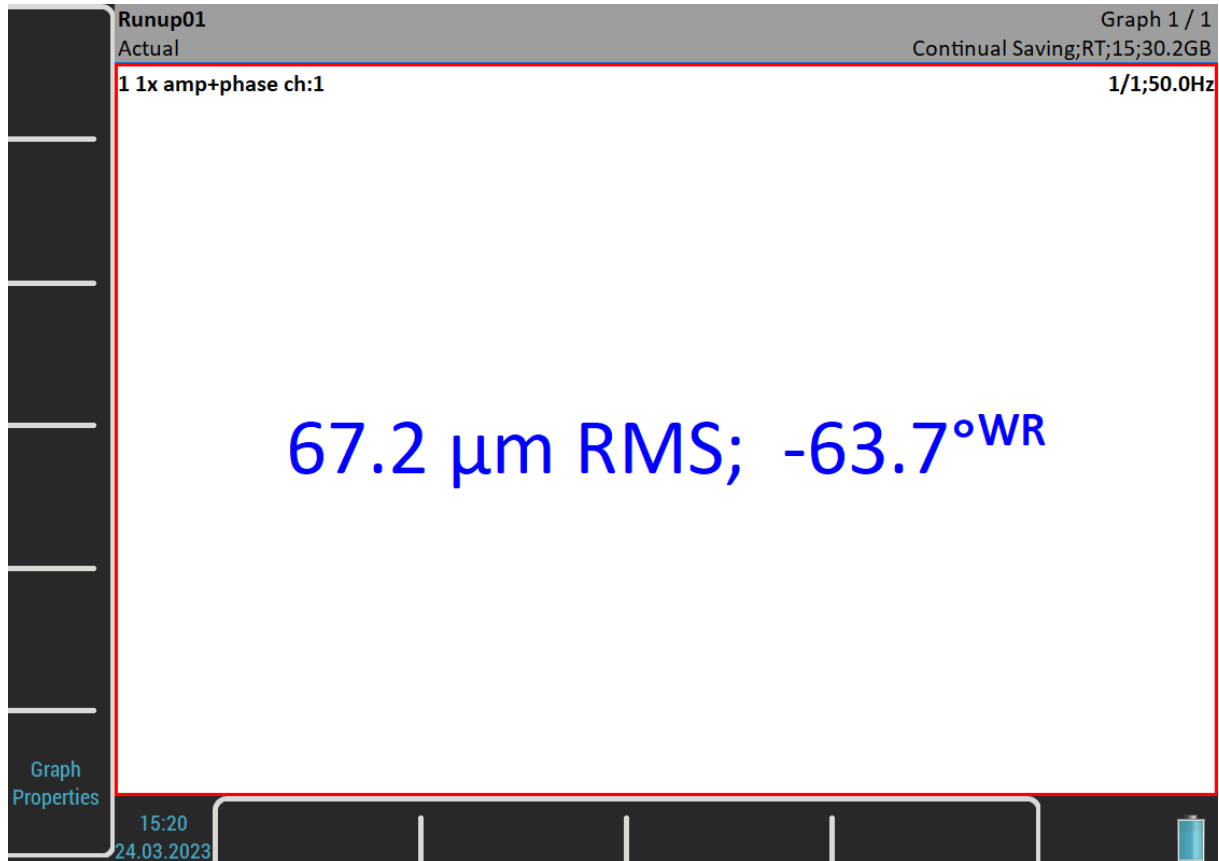

The *Measuring* indicator in the status bar changes into *Continual Saving* during the runup measurement and contains additional information, the number of saved readings (15) and the free memory size (30.2GB).

The set screen looks the same as in the Analyzer module. But there is one difference. The values are saved during the measurement.

The current value is displayed in the picture above. Nevertheless, in the Runup module, you may display a trend during the measurement process already. Use the [Graph Properties](#) / [Display](#) for it.

Push the *Escape* button when you want to stop the measurement process.

## Trends

In the Runup module, unlike in the Analyzer module, one trend is saved during each measurement process. Push the **Set** button and select the **View Trend** item to open a **Trend List**. The date and time of the trends are displayed in the list. If the analysis was made from record, two time stamps are displayed. The analysis time is the first and the record time is the second.

One runup measurement can be divided into more files (into more trends), for example, if the measurement is too long. See [MENU / SETTINGS / Runup](#).

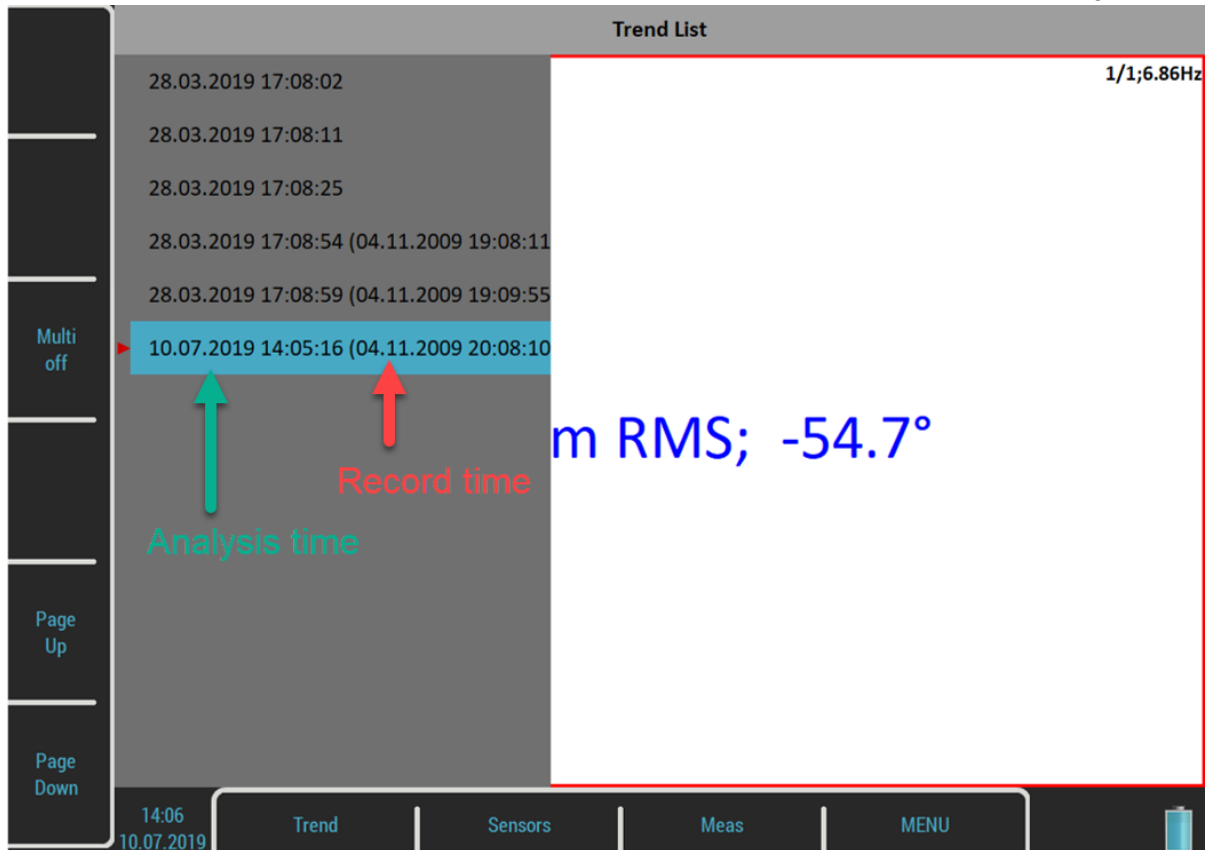

Select one item in the list and open it. The selected trend will be loaded and displayed.

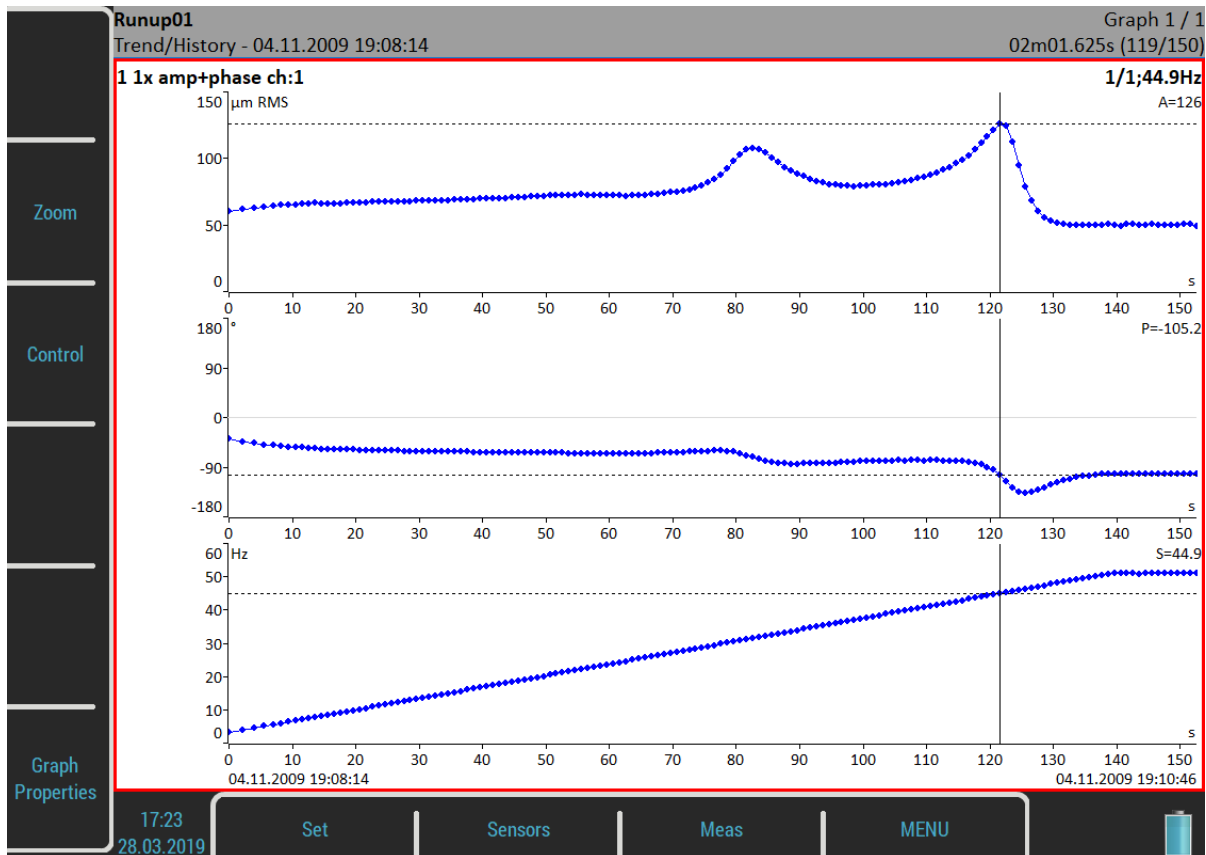

The date and time after the *Trend/History* indicator in the status bar means the beginning of the measurement. The time stamp in the bottom right corner of the status bar means the actual *trend cursor* position and the 119/150 means the index and the total number of readings in the trend. The trend axis is marked from the beginning. This is the default setup. If you want absolute date and time, change the [Trend Time Axis](#) parameter in [MENU / SETTINGS / Runup](#) to a **real time** value.

## **Trend Menu**

When the *trend list* is displayed, a menu to work with the trend list items is available. Push the **Trend** button to open the menu.

### **Delete**

Delete the selected trends.

### **Export**

It is not necessary to export the whole set with all trends. You can export only the trends you need. You find them in the folder named as the current project (set) in the *VA4runup* folder on the *VA5\_DISC*. Then you are able to work with them the same way like you would export the whole project (for example, import to DDS or copy to virtual unit). The project is partially exported.

## **Recorder**

Many of older engineers remember the past time, when the signal was recorded to the tape-recorder and consequently analyzed in Analyzer. Such approach had one important benefit. You can analyze the signal again and again. When you need to make all required analysis in real-time, you are under time pressure. If, for example, the runup can only be run once, the pressure is extreme. The tape-recorder was the solution. It was a simple unit with simple operation, no danger of losing the data. The same solution offers the Recorder module. It enables you to simultaneously record all four AC and DC inputs and the TRIG input into the memory.

## ***Project List***

For management purposes, **records** are referred as **projects**. The list of saved projects opens when you enter the Recorder module. The list is empty if you have no saved records yet. The recording date and time of the selected project is displayed in the status bar in the bottom right corner.

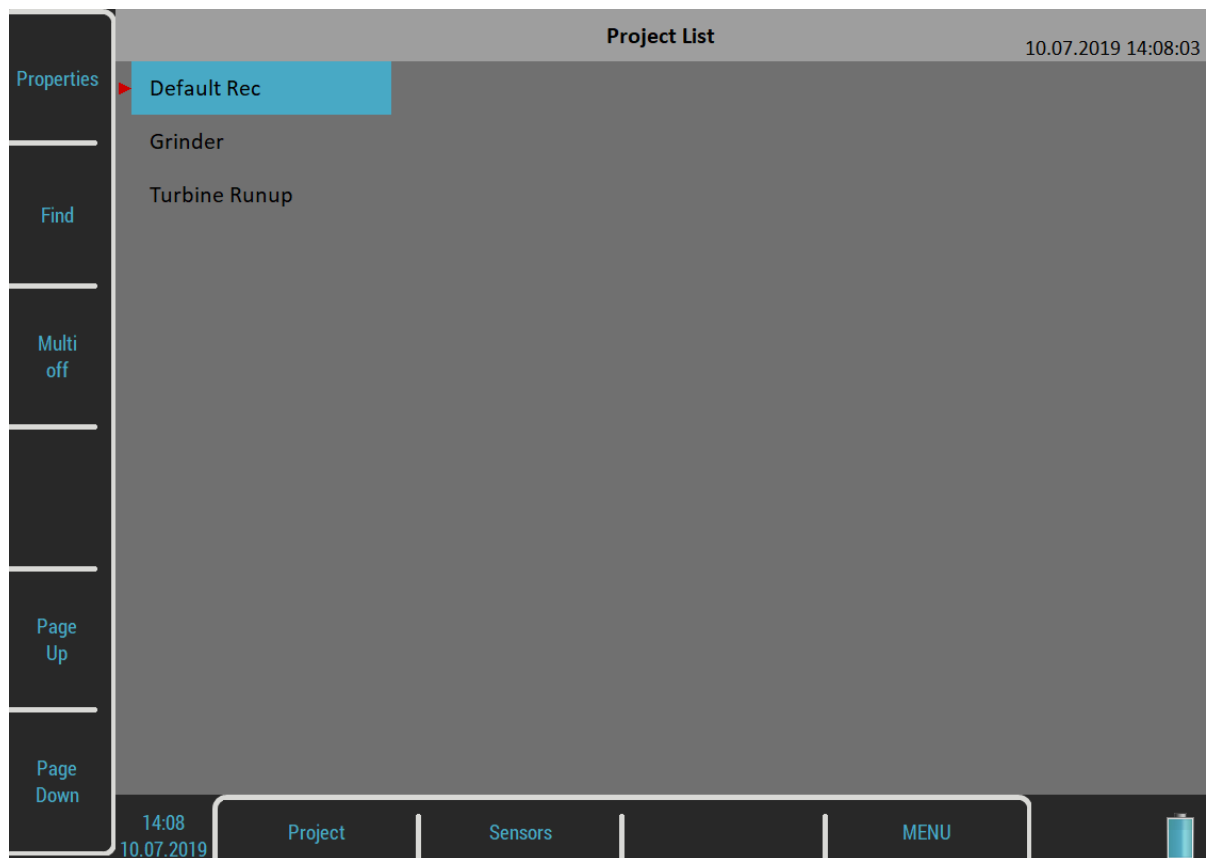

## ***Project Menu***

Use the **Project** button to manage the records in the list.





### ***New***

Creates a new project (record) and adds it to the *Project List*.

### ***Copy***

Copies only the parameters of the selected project, no recorded signals will be copied.

### ***Rename***

Renames the selected project.

### ***Delete***

Deletes the selected project.

### ***Clear Data***

Deletes the signal in the selected project, all record's parameters are kept.

### ***Notes***

Adds a note to the selected project. The [Notes](#) dialog had already been introduced in the [Route](#) module.

### ***Export***

Exports the selected project to [VA5\\_DISC](#).

**Attention!** The maximum record size that can be exported is 4 GB which represents 80 minutes of 4 channel recording with 65536 Hz sampling frequency. When you want to export a larger record, then the error “*Not enough space*” appears. You need to split a large record to several smaller records. See the [Record Preview](#) chapter.

### ***Export to wav***

Exports the selected project as a wav data format. The wav files are saved to a *wav* folder on *VA5\_DISC*. You may choose the 24 bit or 16 bit encoding of the wav file using [MENU / SETTINGS / Global Settings / Wav Encoding](#). Additional settings can be done using the [Export to wav Settings](#).

### ***Export to wav Settings***

Opens the [Export to wav Settings](#) menu.

## Export to csv

Exports the selected project as a csv file. The csv files are saved to a csv folder on VA5\_DISC.

On the first line of the csv, there is a record's sampling frequency in Hz in format:  
*fs:65536;*

The next line contains used channels and their physical units:  
*AC1[g];AC2[g];TRIG;*

Then, the values of all signals and eventually the trigger are stored by columns.  
*0.499992;0;1;*  
*0.499992;0.00238538;0;*  
*0.499975;0.00478721;0;*  
*0.499942;0.00718904;0;*  
 ...

## Record Settings

The *Record Settings* menu opens automatically when you open a project without data. You can also open the menu by the **Recorder** button when a record is opened. You don't lose any measured data by editing the settings.

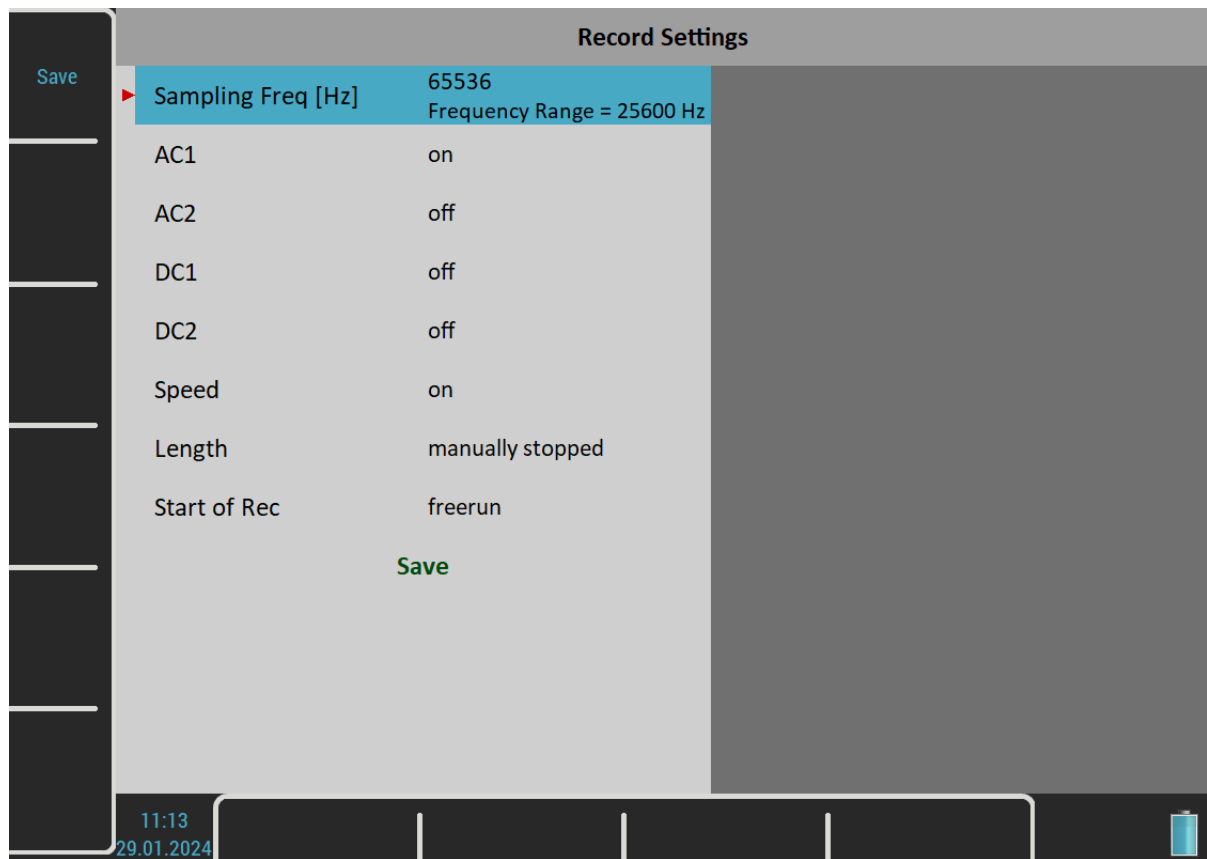

### Sampling Frequency

The sampling frequency used by recording. The available frequency range of the recorded signal is in the note under the value.

### AC1 – AC4, DC1 – DC4

Switch to **on** at all channels you want to record.

### Speed

You set here if the speed is in the preview. Tacho pulses are always saved.

**Time**

Defines the length of the record in minutes or **manually stopped**.

**Start of Rec****freerun**

The recording is started immediately after the measurement's preparation.

**External**

The recording is started when a signal on TRIG input exceeds a threshold level which is defined in [MENU / SETTINGS / Trigger Settings / External Trig Level \[V\]](#)t. Such signal may be generated, for example, when a machine starts to work. This type of signal is usually created in the control system.

**amplitude**

The recording is started when the signal level on the **Ampl Trig Channel** exceeds the **Ampl Trig Level**. The **Ampl Trig** parameters are available only if the **amplitude** is chosen.

| Start of Rec        | amplitude |
|---------------------|-----------|
| Ampl Trig Channel   | 1         |
| Ampl Trig Level [g] | 1         |
| Pretrig[minutes]    | 0         |

**Pretrig**

When the [Start of Rec](#) event occurs, the recording is started. But you are able to save a signal before the event by defining the *Pretrig* length.

**Recording**

Remember to setup all sensor properties before recording. Use the [Sensors](#) menu. When the sensors and record parameters are set, use the *Enter* button to start the recording.

If the record already contains data, you will be warned and you can cancel the measurement.

Record contains data.  
Data will be rewritten.

All recorded input signals are displayed on the screen during the recording.

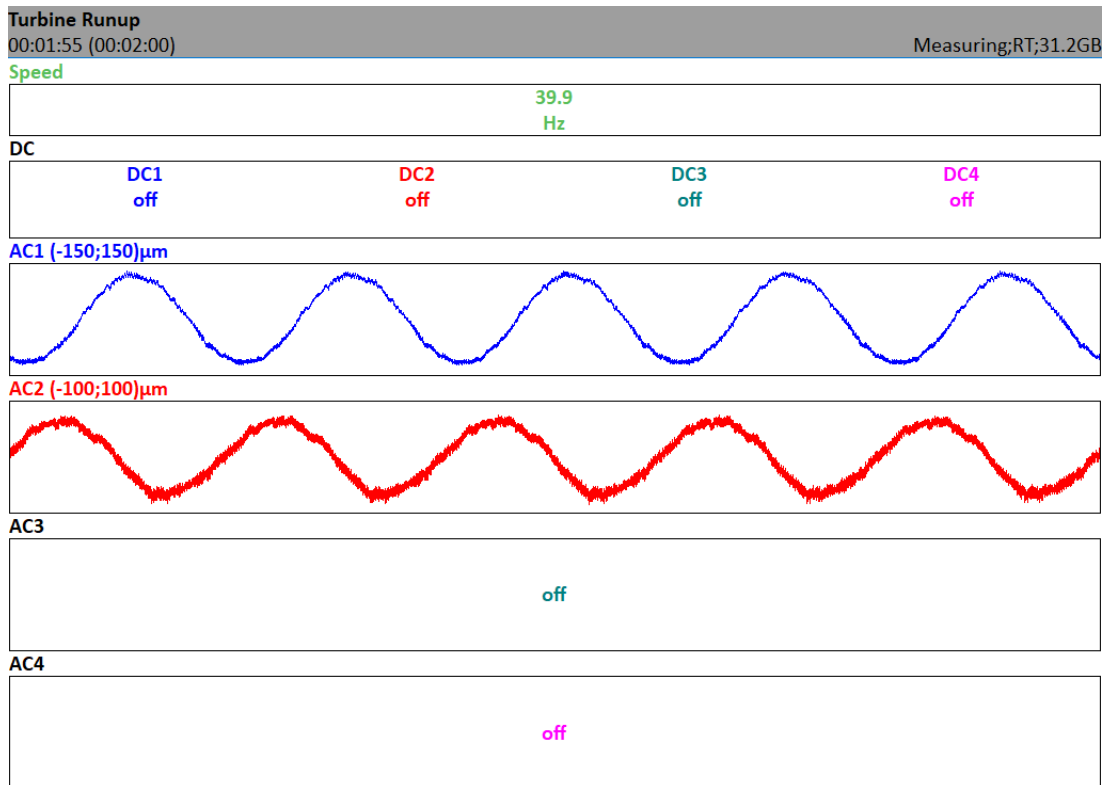

Elapsed and demanded time is displayed in the status bar bottom left corner. The available memory is in the bottom right corner.

The recording is finished when

- the time is over,
- manually, by the *Escape* button,
- the memory is full.

### **Record Preview**

The preview of recorded signals is displayed after the record is taken.

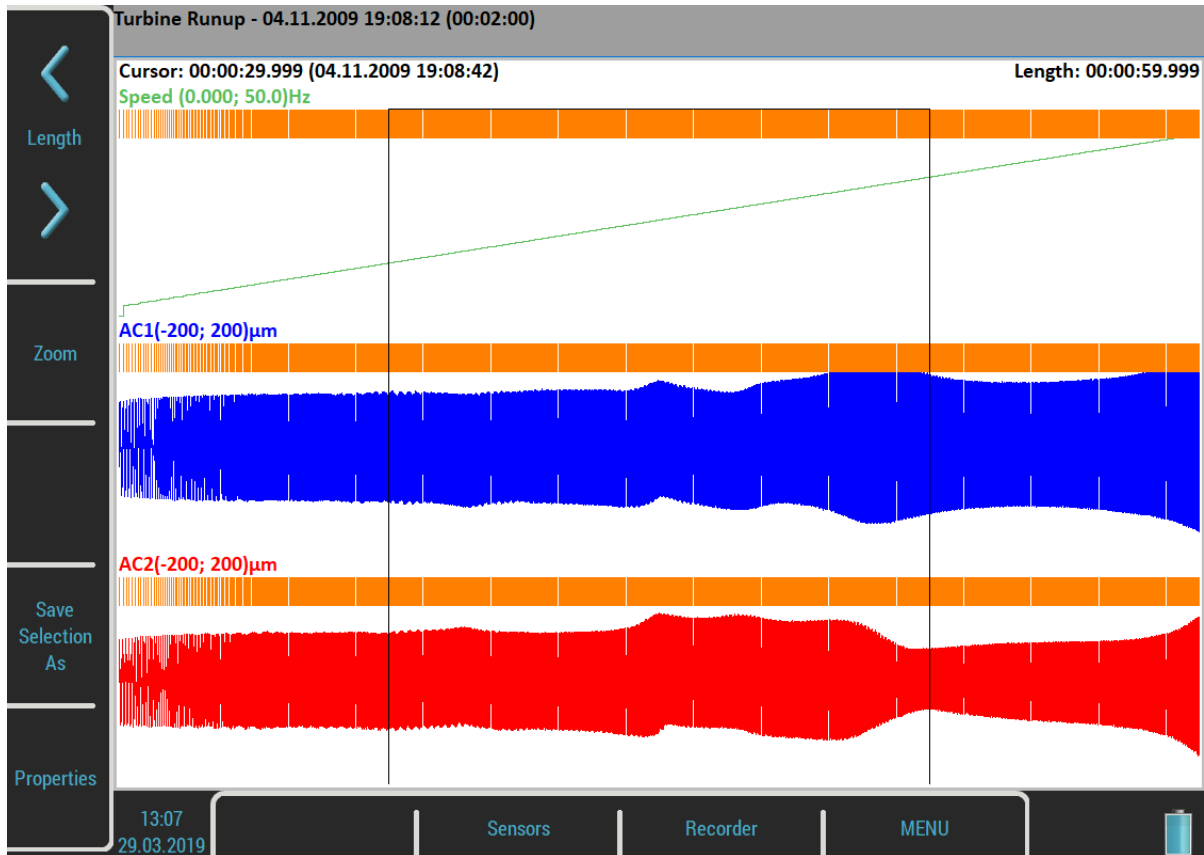

The record date, time and length are displayed behind the record's name in the status bar.

The selection cursor is displayed over the signals. The **Cursor** label shows the beginning of the selection measured from to the beginning of the record and also in absolute time. You can move the cursor with the *Left* and *Right* buttons. The **Length** of the selection can be changed with the **Length** arrows. You can also use touch screen gestures.

You can zoom the record using the **Zoom** button. Zoom X is applied to the selection area.

The **Tab** button switches the side buttons meaning between the **Zoom** and initial mode. The **Backspace** button returns the initial mode.

When the record contains longer data than you need for analysis, you can select any part and save it as a new record. The **Save Selection As** does it. The **Cursor** defines the beginning of the new record. The **Length** defines the length of the new record.

The **Properties** button opens a window with the information about the record.

The **Enter** button starts a new recording if you want to rewrite the signals. You will be warned before the data erasing.

The **Escape** button closes the preview and skips back to the [Project List](#).

## Export to wav Settings

This menu can be opened by the **Project** button when the [Project List](#) is on screen.

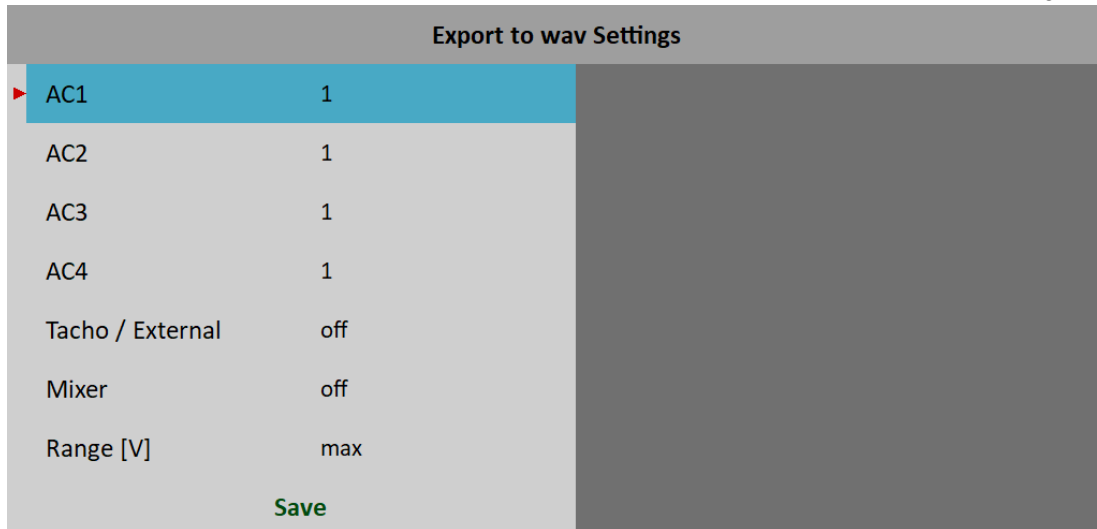

### **AC1 – AC4**

All channels can be mixed to one channel into a wav file (like in music studio). The gain factor can be defined for each channel. When zero is used, this channel will not be used for mixing.

### **Tacho / External**

**on, off**

If it is turned on, tacho / external pulses will be exported as standalone channel.

### **Mixer**

**on, off**

Select **on** when you want to mix all channels to one channel wav file. If the **off** is used, then multichannel wav file will be created. The gain factors are used in both options.

### **Range [V]**

The full AC range of the instrument is +/- 13.8 V (even if a value above 12 V is considered an overload). This range is also used for wav export, i.e., a sample with 13.8 V will be saved as maximum in wav. But it is usually too much, because the real voltage level is much lower, e.g., hundreds of millivolts with an accelerometer 100mV/g. The wav file is then very quiet. The *Range* option enables you to apply better wav range and better hearing from headphones.

#### **1.5**

This range should generally be acceptable in most of cases.

#### **max**

The value of 13.8 V is saved as maximum in wav. The range of wav is 13.8 V.

#### **auto**

The reached maximum value in a signal is used as wav range.

#### **user**

You may enter any value.

**Attention!** If you need to compare two signals in headphones (for example, the noise of old and new bearing), then the same range must be used.

**Attention!** When the range value is lower than the range of the signal, then the warning "**Wav overload**" appears after the export.

***Temporary record***

Records can be stored in the DDS database. For record analysis, the DDS copies one record into the list of records in the Virtual Unit and runs the Virtual Unit. We call this record temporary. It will be deleted once you close the Virtual Unit.

## **Balancer**

The balancing process is based on standard measurements of amplitude and phase on the speed frequency. If you are not familiar with field balancing method, please see any special literature.

### ***Planes and Points***

We would like to explain the difference between the words 'plane' and 'point'. The sensor is mounted to the point or points (dual channel reading). The trial mass and final masses are mounted to the plane or planes. Some people talk about measuring on planes, but this is not correct. In case of overhanging rotor there is no direct relationship between points and planes.

We use the labels A and B for points and 1 and 2 for planes.

### ***Project***

The Project is the base structure in balancer. It corresponds to one balancing job. You can use the same Project for repeated jobs on the same machine. The measured data will be rewritten.

The Project contains all measured or entered data, which were used during the job.

The typical scheme looks like the following list of steps:

- Create new project.
- Enter balancing parameters (type of machine, number of planes etc.).
- Initial measurement of vibration amplitude and phase on required measurement points.
- Put trial weight on the rotor. Step by step to all planes.
- Trial weight response measurement. Step by step to all planes.
- Put correction weights on all planes.
- Check of effect (success).
- Trim measurements for additional weights and better results.

Every step is displayed in one screen. The movement between screens is provided by **Up / Down** arrows.

**Attention!** When you return back in the job screens and you take a repeated measurement or enter a new value, then the measured data will be erased in all screens after the current screen. The reason is simple. The parameters in the next screen are derived from the previous screen. When you repeat the measurement, you change these parameters. That is why all following screen parameters must be removed and you have to make all necessary measurements again.

### ***Project List***

The list of saved projects opens when you enter the Balancer module. The list is empty if you do not have saved projects yet. The modification time stamp of the selected project is displayed in the status bar in the bottom right corner.



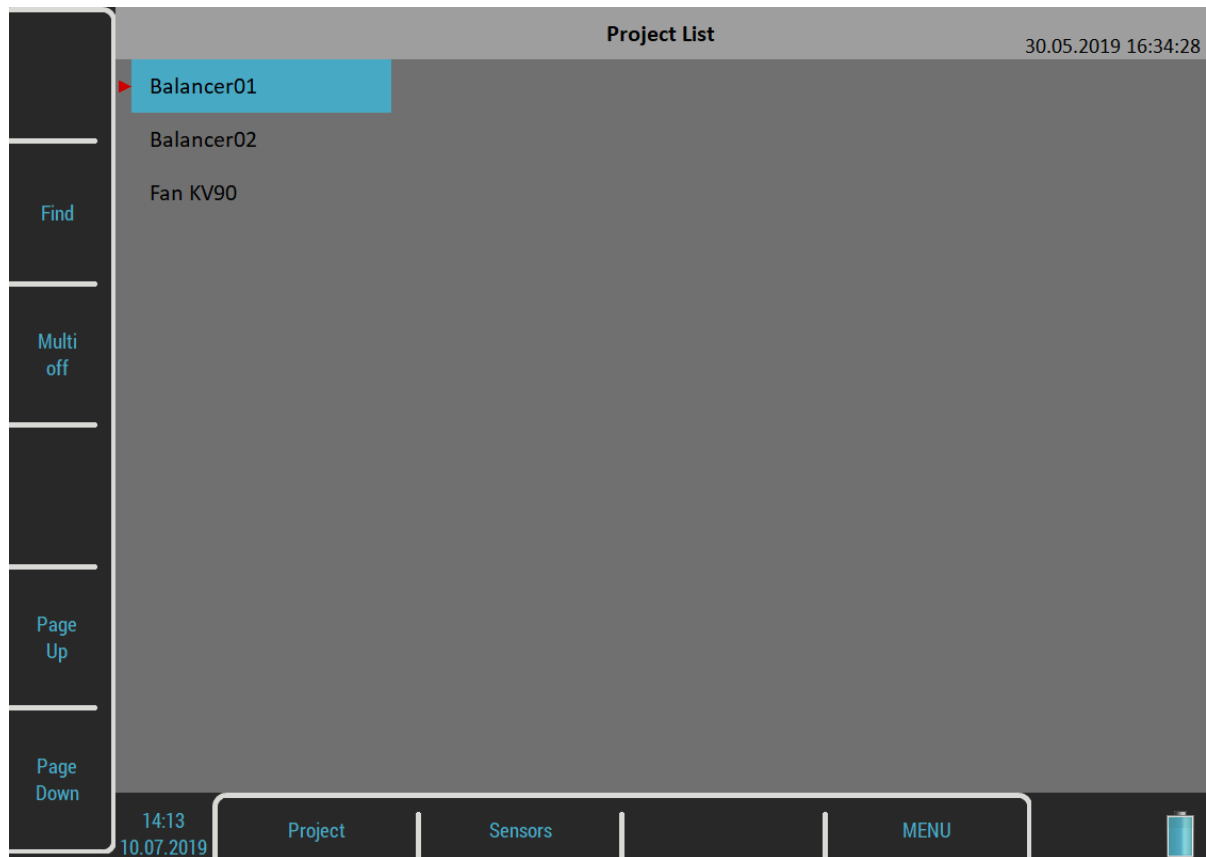

## ***Project Menu***

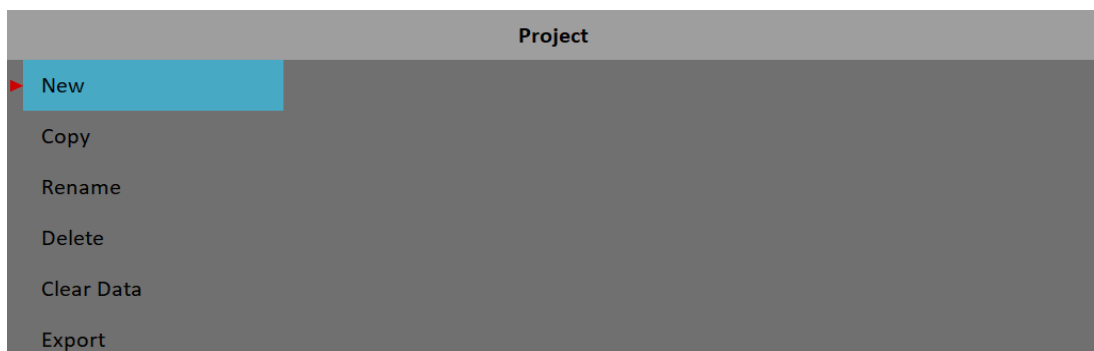

### ***New***

Creates a new project with default properties.

### ***Copy***

Creates a new project as a copy of the selected project. Only the header data are saved. No measured data are saved.

### ***Rename***

Renames the selected project. The project with the old name does not exist anymore.

### ***Delete***

Deletes the selected project.

## Clear Data

Erases all measured data, only the project header remains.

## Export

Exports the selected project to *VA5\_DISC*.

**Note!** The Balancer projects are automatically exported during closing. You don't need to export them manually. The *Export* item can be used in case you delete the project from the *VA5\_DISC* and want to export it again.

## Balancer Settings

A [Basic Settings](#) menu automatically opens when you open a project which has no data yet. You may open the menu later using the **Balancer Settings** button. There are three separate menus under this button, [Basic Settings](#), [Units Settings](#) and [Rotor Settings](#).

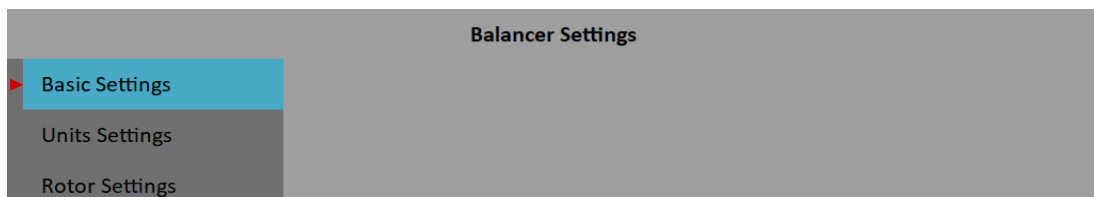

## Basic Settings

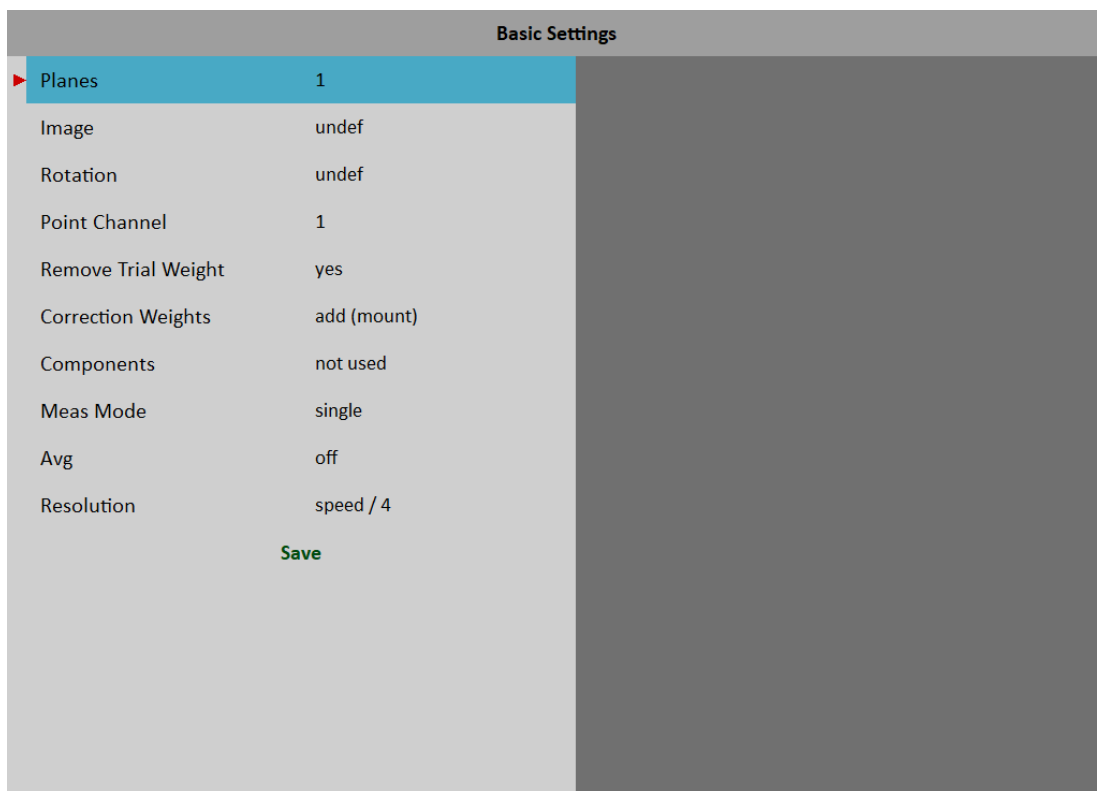

### Planes

**1, 2**

Number of balancing planes.

### Image

Selection of the machine image, different images are available for 1 or 2 plane balancing

**Look**

**left, right**

View direction. Available only if the Image has been defined. Moreover, not all images enable the look.

|       |                |
|-------|----------------|
| Image | overhung rotor |
| Look  | right          |

**Right:**

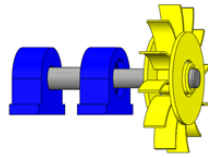

**Left:**

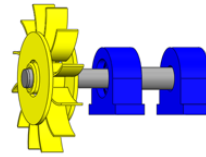

**Rotation**

**CW, CCW**

Clockwise or counterclockwise

**Point Channel**

The number of AC input, which will be used for the sensor mounted on the measurement point, for 1 plane balancing

**Point A Channel, Point B Channel**

Numbers of AC inputs, which will be used for the sensors mounted on the measurement points, for 2 planes balancing

**Note!** You can enter the same AC channel number for both A and B point. In this case, the measurement with one sensor is expected and readings for both points are not taken together. First, you take the measurement on one point. Then, you remount the sensor to the other point and take next reading. The point which is currently measured is selected by the Left / Right button (see later).

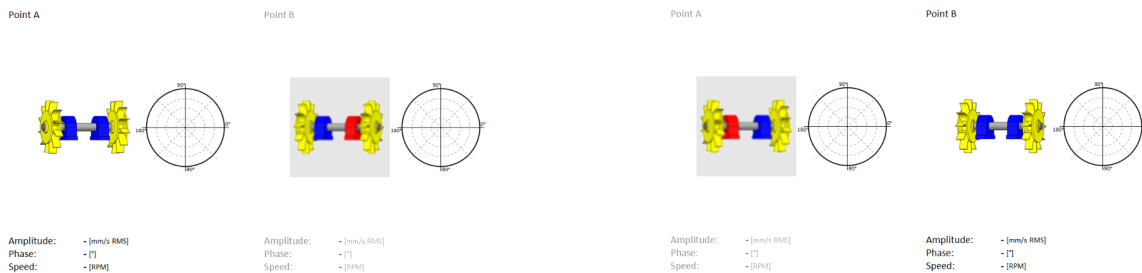

**Note!** The measurement points marking A and B only have a symbolic meaning. It has no relation to the balancing planes 1, 2 and to the balancing computational procedure. You can mark any point as A and the second as B.

**Remove Trial Weight**

**yes, no**

The trial mass can be left on the rotor or it can be removed from the rotor after trial run.

**Remove Trial Weight (Plane 1)**

**yes, no**

For 2 planes balancing, you may remove or keep trial on each plane individually.

**Remove Trial Weight (Plane 2)**

**yes, no**

For 2 planes balancing, you may remove or keep trial on each plane individually.

## Correction Weights

**add (mount), remove (drill)**

### Components

Number of components. This parameter is used in a job requiring you to divide the correction weight between components (blades, for example).

### Meas Mode

**single, online meter**

When you start a measurement process by pushing *Enter*, only one value can be taken (**single**), or continual measurement values could be displayed (**online meter**). In **online meter** mode, you may look at more values and evaluate their change in time. You need to stop the measurement by pushing *Escape/Stop* when the value you want to see is displayed.

### Avg

The averaging of more than one measured value is available.

### Resolution

It's the aps measurement resolution described in [Analyzer](#) / [Edit Measurement](#) / [Resolution](#).

## Units Settings

Set the units for the current project.

| Units Settings    |      |
|-------------------|------|
| ▶ Amplitude       | mm/s |
| Detect Type       | RMS  |
| Speed             | RPM  |
| Mass              | g    |
| Rotor Mass        | kg   |
| Correction Radius | mm   |
| Unbalance         | g-m  |
| <b>Save</b>       |      |

### Amplitude

Selection from available vibration units.

### Detect Type

**RMS, 0-P, P-P**

Detect type for amplitude value

**Note!** This value is the same as the global value defined in [MENU / SETTINGS](#) / [Spectrum Settings](#) / [Detect Type](#) until you change it here. That means, if you change the global value, it will also be changed here. This will stop after the first time you enter a value here.

### Speed, Mass, ...

Selection from available units for a particular quantity.

## Rotor Settings

| Rotor Settings          |                         |
|-------------------------|-------------------------|
| ▶ Operating Speed [RPM] | same as balancing speed |
| Rotor Mass [kg]         | -                       |
| Correction Radius [mm]  | -                       |
| Quality Grade           | -                       |
| <b>Save</b>             |                         |

All parameters are optional. It enables you to calculate unbalance and balancing quality factor according to *ISO 21940*.

### **Operating Speed**

One of the parameters used for Quality Grade calculation is the speed of the rotor. By default, the Quality Grade calculation uses the speed detected during the balancing process. However, sometimes the real operating speed differs from the balancing speed. In this case, you can enter the operating speed here and this speed will be used for Quality Grade calculation.

### **Rotor Mass**

Rotor mass

### **Correction Radius**

Radius to which the correction weight will be mounted (could be different for each plane)

### **Quality Grade**

Required quality grade according to *ISO 21940*. If this value is entered, the recommended trial weight can be offered.

**Initial Run**

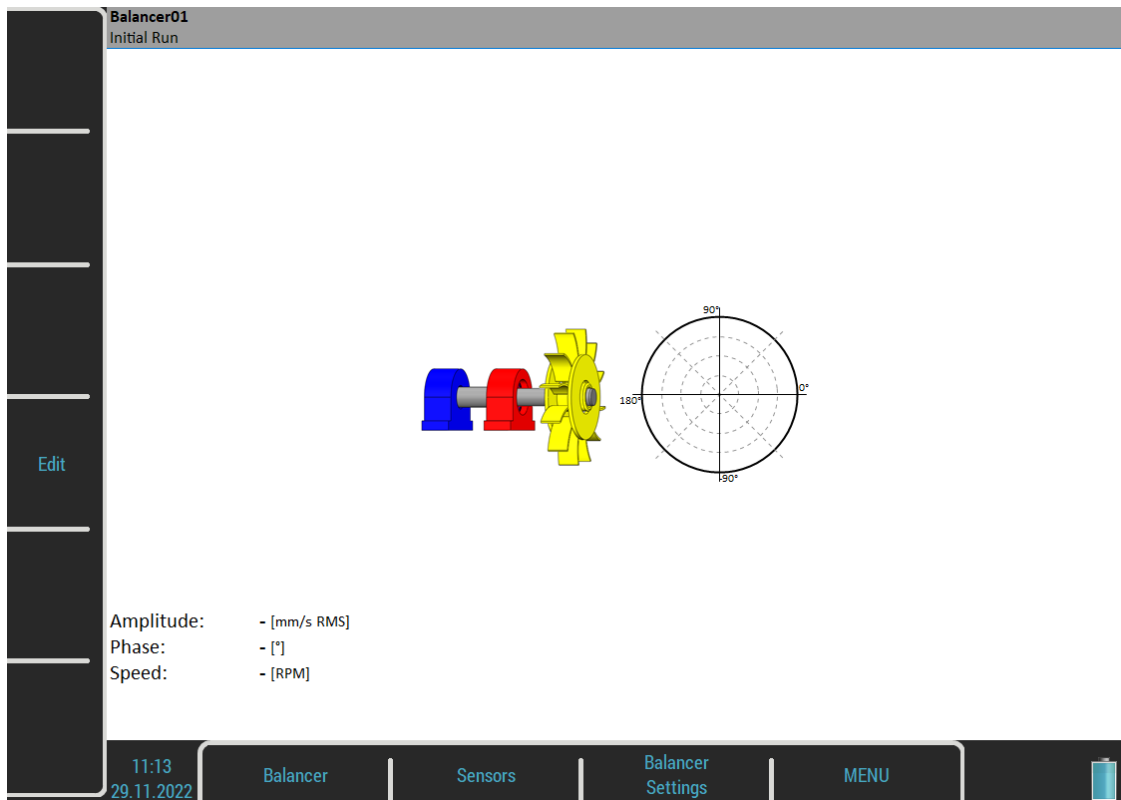

The red bearing house is the recommended point for sensor mounting, but you can use any other place which is suitable for measurements. The polar graph is prepared to display measured values. Push the **Enter/Start** button to start the measurement process. Alternatively, you may press the **Edit** button and enter all values manually (balancing calculator function).

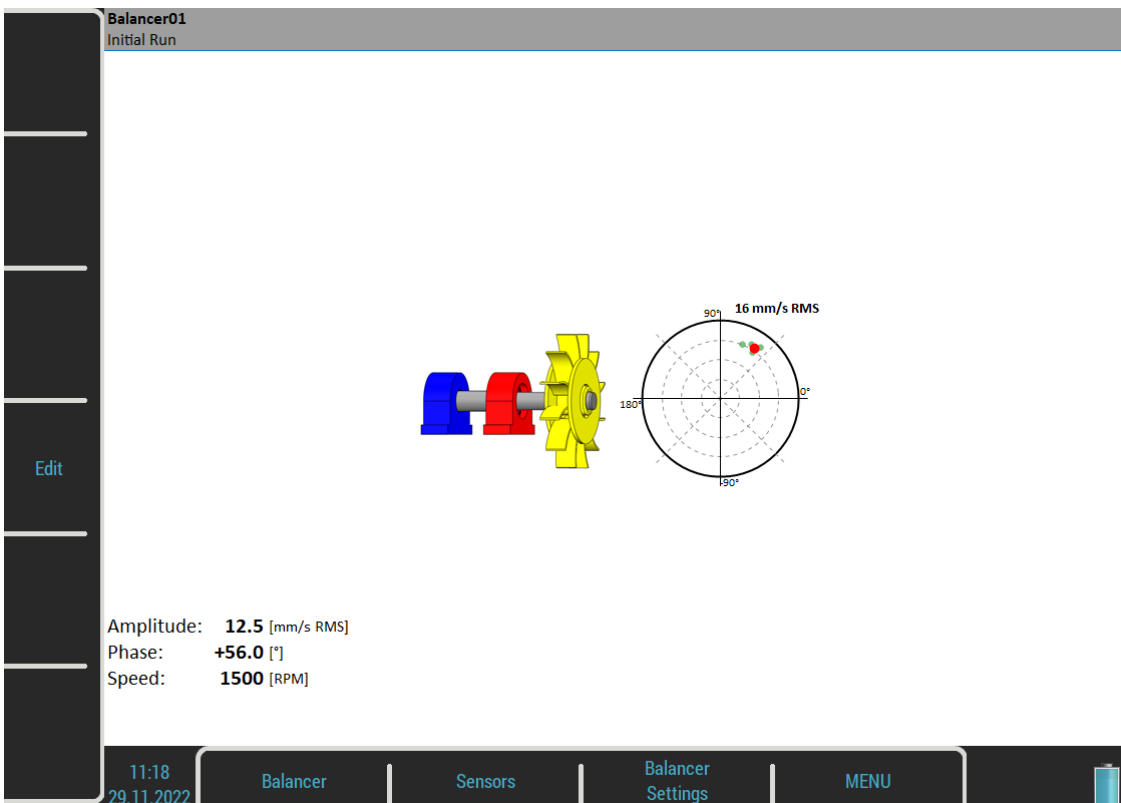

The red dot on the polar graph shows the current amplitude and phase in the complex plane. Smaller green dots show all values during the measurement process when the [Meas Mode](#) is set as **online meter**.

**Warning!** The polar graph represents the complex plane, which only graphically illustrates the amplitude and phase of measured value as complex number. It is not intended to show a heavy spot in a real position and direction. Therefore, no setup (as angles counting, direction of rotation or view unit) has an effect on the polar graph orientation.

Press the **Down** arrow to move to the next screen.

## Trial Run

Trial weight response is measured in this run.

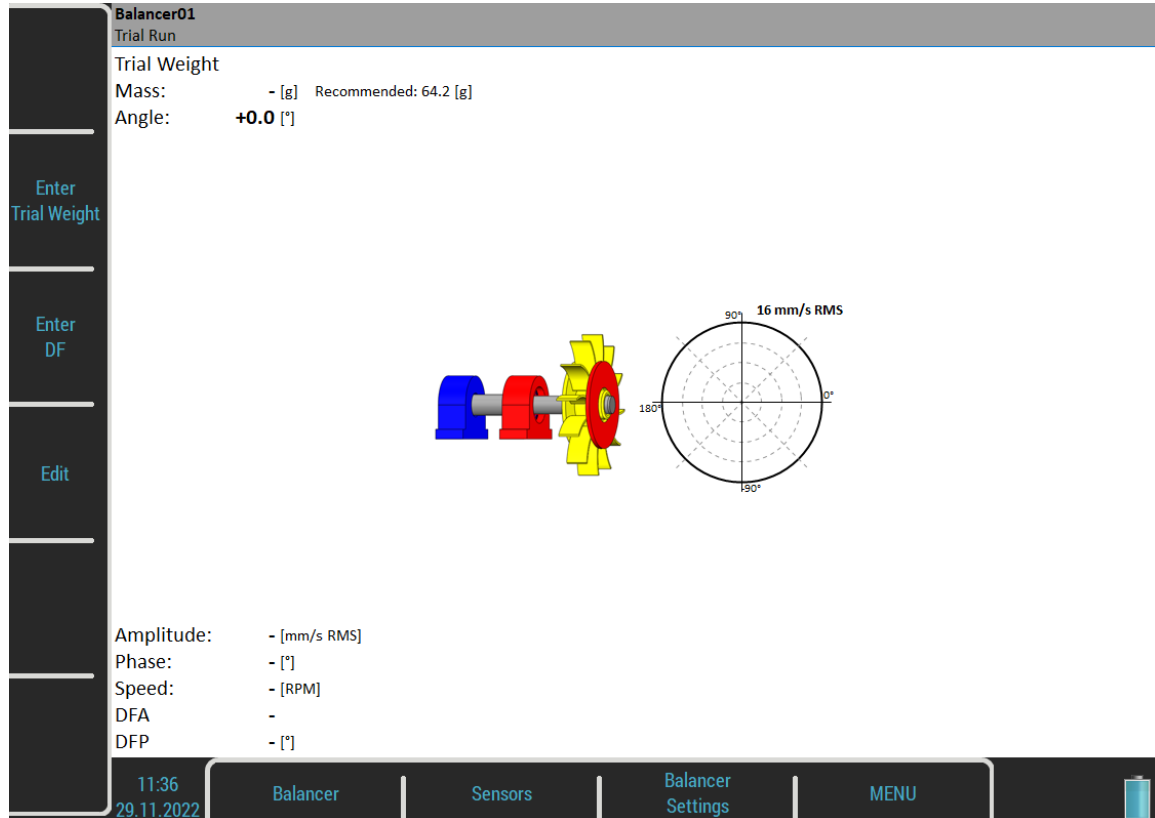

Push the **Enter Trial Weight** button and enter the mass and angle of the trial weight. The trial weight is usually placed at zero angle and serves as a zero mark. However, you can set the zero mark wherever and set the trial weight angle from the zero mark. The angle of the trial weight must keep the [Global Settings / Angles Counting](#) setup. This means, if you use **with rotation** angles counting, the angle is positive when you put the trial weight before the zero mark in the direction of rotation, and negative when you put the trial weight behind the zero mark (or when the trial goes first and the zero mark goes second, the trial weight angle is positive). For **against rotation** angles counting, it is the opposite.

If the [Components](#) have been defined, the trial weight position is entered as the number of the component. The angles counting must be kept as well. The component number grows in the direction of rotation if **with rotation** is set and vice versa.

The mass can be negative, it represents removing of the weight (for example, dismounting an old correction weight).

The recommended weight value is displayed only if the [Rotor Settings](#) parameters are entered.

Don't forget to mount the trial weight to the balancing plane.

**Balancer01**  
Trial Run

Trial Weight  
Mass: **70** [g] Recommended: 64.2 [g]  
Angle: **+0.0** [°]

Enter Trial Weight

Enter DF

Edit

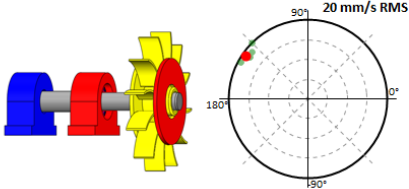

Amplitude: **19** [mm/s RMS]  
Phase: **+145.0** [°]  
Speed: **1500** [RPM]  
DFA: **322**  
DFP: **+178.6** [°]

11:54  
29.11.2022

Balancer Sensors Balancer Settings MENU

After the trial run measurement, the **dynamic factor** of the machine is displayed. The **DFA** and **DFP** (amplitude and phase) values are the response values of a standardized trial mass on the correction radius. If you balance the same machine again after some time, then you do not need to measure the trial weight response again. Instead, you may just enter the **DFA**, **DFP** values on this screen. Use the **Enter DF** button for that.

**Result**

**Balancer01**  
Mass and position of correction weight

Init. Unbalance: **7.75** [g·m] max: 1.6 [g·m]  
Init. Quality: **30.4** max: 6.3

▼: Trial Weight Position

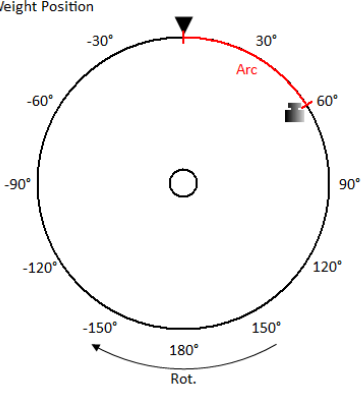

Correction Weight 1  
Trial weight removed

Mass: **38.8** [g]  
Angle: **+57.4** [°]  
Arc: **200** [mm]

13:06  
29.11.2022

Balancer Sensors Balancer Settings MENU

According to the [Basic Settings / Remove Trial Weight](#), the information window appears.

Remove trial weight!

or

Keep trial weight!



Don't forget to remove the trial weight if it is set. However, you can use it as a zero mark first and remove it after correction weight mounting.

If you have entered [Correction Radius](#) and [Rotor Mass](#) values in the [Rotor Settings](#) menu, the **Initial Unbalance** and **Balancer Quality** values according to *ISO 21940* are displayed. In case the values are satisfactory, you don't need to continue with the balancing job.

**Note!** The **Initial unbalance** means that a trial weight is not taken into account, even if it is kept.

The mass and angle (position) of the correction weight are displayed.

The angles are calculated from the zero mark. The direction of the angle depends on the [MENU / SETTINGS / Global Settings / Angles Counting](#) value. If it is set as **with rotation**, the angle direction is the same as the direction of rotation and positive values are in the direction of rotation (in the picture above it is +57° in the direction of rotation). If the Angles Counting value is set as **against rotation**, the angles have opposite values.

**With rotation:**

Init. Unbalance: **7.75** [g·m] max: 1.6 [g·m]  
 Init. Quality: **30.4** max: 6.3

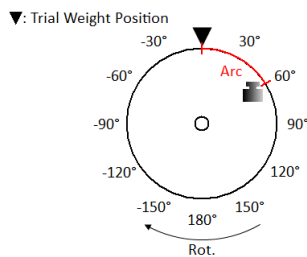

Correction Weight 1  
 Trial weight removed

Mass: **38.7** [g]  
 Angle: **+57.4** [°]  
 Arc: **200** [mm]

**Against rotation:**

Init. Unbalance: **7.75** [g·m] max: 1.6 [g·m]  
 Init. Quality: **30.5** max: 6.3

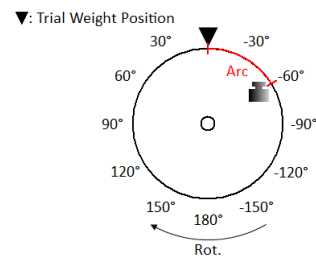

Correction Weight 1  
 Trial weight removed

Mass: **38.8** [g]  
 Angle: **-57.4** [°]  
 Arc: **200** [mm]

**Warning!** If you had not defined the direction of rotation, the result is displayed in the default direction with angles increasing counter clock wise. The angle still has the same value (+57° with rotation or -57° against rotation). However, the picture may not correspond the reality. You need to determine the right position yourself.

**With rotation:**

Init. Unbalance: **7.76** [g·m] max: 1.6 [g·m]  
 Init. Quality: **30.5** max: 6.3

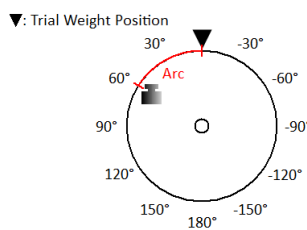

Correction Weight 1  
 Trial weight removed

Mass: **38.8** [g]  
 Angle: **+57.4** [°]  
 Arc: **200** [mm]

**Against rotation:**

Init. Unbalance: **7.75** [g·m] max: 1.6 [g·m]  
 Init. Quality: **30.5** max: 6.3

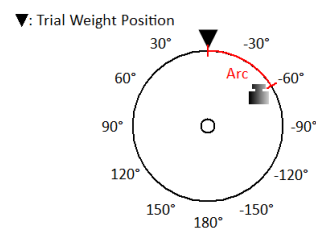

Correction Weight 1  
 Trial weight removed

Mass: **38.8** [g]  
 Angle: **-57.4** [°]  
 Arc: **200** [mm]

**Note!** You cannot change the Angles Counting value during a balancer job. If the value is changed, this error message appears.

**Balancing Error**  
 Angles counting in project is different from settings in instrument.  
 Change the value in menu Global Settings / Angles Counting or create new project.

In case you have entered the [Correction Radius](#) value, the **Arc** value shows a circumferential distance of the correction weight from zero mark.

You can split the correction mass into two arbitrary angles (in case it is not possible to place the correction mass into calculated position). Use menu **Balancer / Split correction weight**

Enter the value of the first angle.

|                       |
|-----------------------|
| Enter first angle [°] |
| 30                    |

Then enter the value of the second angle.

|                        |
|------------------------|
| Enter second angle [°] |
| 60                     |

The balancing mass will be recalculated (split) into two required angles.

Init. Unbalance: **7.76** [g·m]    max: 1.6 [g·m]  
 Init. Quality: **30.5**    max: 6.3

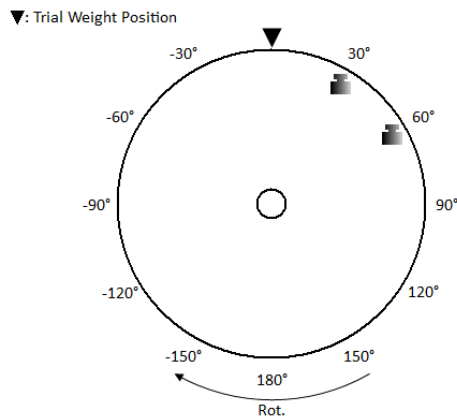

Correction Weight 1  
 Trial weight removed  
 Mass 1: **3.55** [g]  
 Angle 1: **+30.0** [°]  
 Mass 2: **35.7** [g]  
 Angle 2: **+60.0** [°]

Use **Balancer / Set Default Angle** to return back to the original calculation.

If the [Components](#) have been defined, the correction weight is divided between the two nearest components. The component number is counted from the zero mark, which is the component number one. The component numbers keep the angles counting parameter. The component number grows in the direction of rotation if with rotation is set and vice versa.

Init. Unbalance: **7.76** [g·m] max: 1.6 [g·m]  
Init. Quality: **30.5** max: 6.3

▼: Trial Weight Position

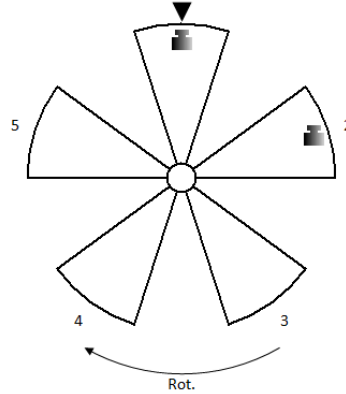

Correction Weight 1  
Trial weight removed  
Mass 1: **10.3** [g]  
Component 1: **1**  
Mass 2: **34.3** [g]  
Component 2: **2**

You can select other components in case when you cannot mount the weight to the nearest components. Select the **Balancer / Change Components** menu item.

Enter the number of the first component.

Enter first component (1 - 5)

Then enter the number of the second component.

Enter second component (1 - 5)

New correction weights will be displayed.

Init. Unbalance: **7.76** [g·m] max: 1.6 [g·m]  
Init. Quality: **30.5** max: 6.3

▼: Trial Weight Position

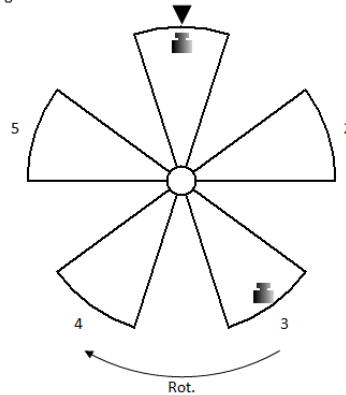

Correction Weight 1  
Trial weight removed  
Mass 1: **65.9** [g]  
Component 1: **1**  
Mass 2: **55.6** [g]  
Component 2: **3**

Select the **Balancer / Set Default Components** menu item to return to the original weights.

Mount the recommended correction weight to the machine.

### Correction Run

When the weight is mounted you want to check the job.

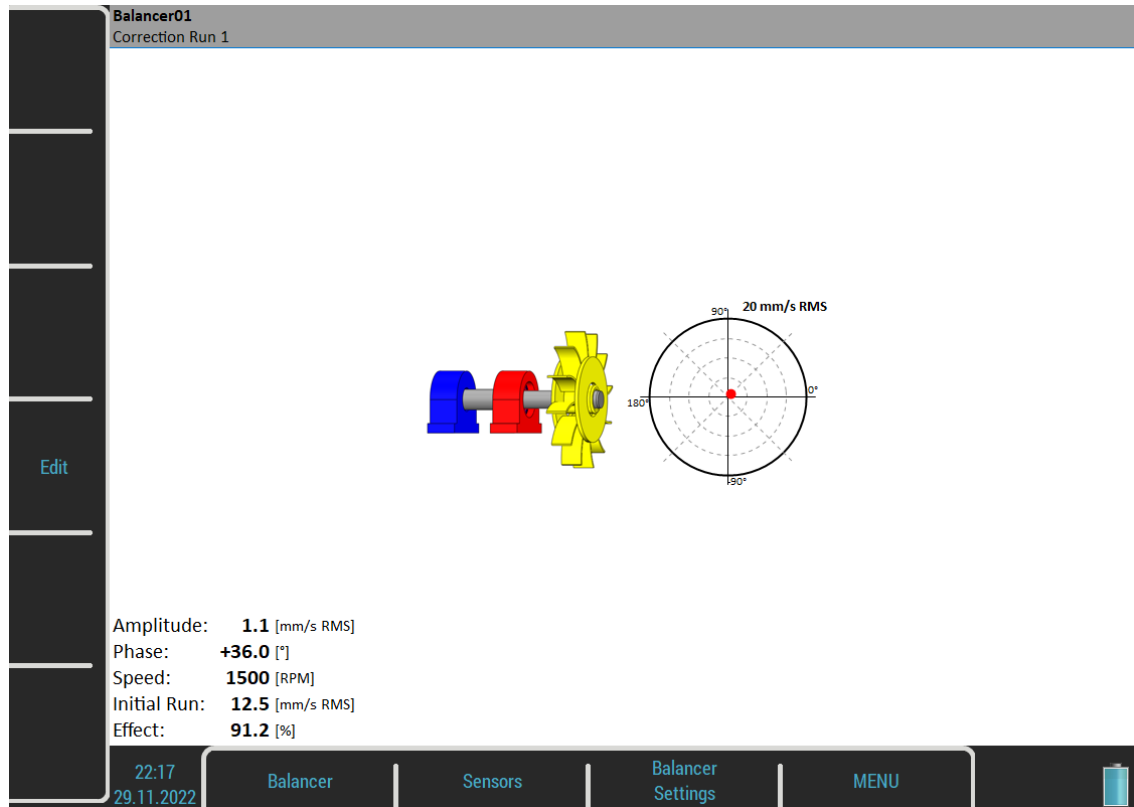

- **Initial Run**  
amplitude of Initial Run
- **Effect**  
is the reduction of balancing in %  
 $Effect = (1 - A2 / A1) * 100\%$   
(the 1.1mm/s is the 8.8% of 12.5 mm/s)

Residual unbalance and quality are available in the next screen together with next correction weight suggestion.

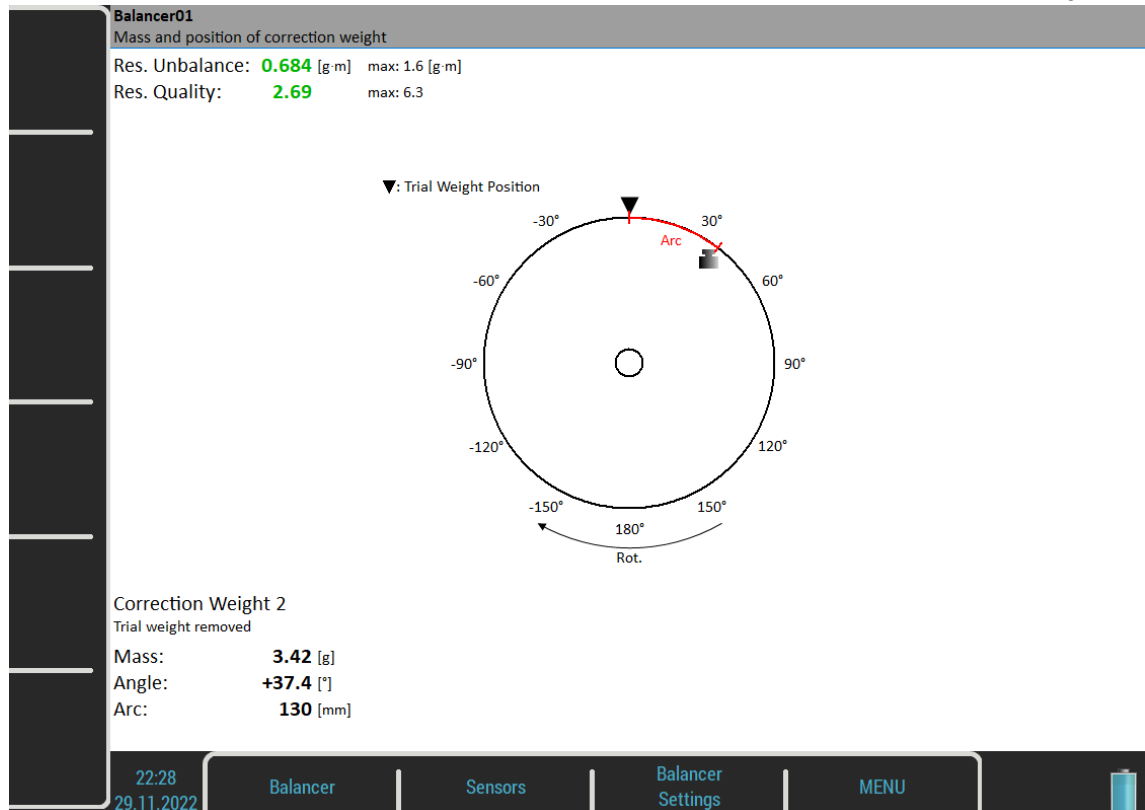

You can continue with the job until you are satisfied with the results. These next steps do not require trial weight measurement. After each measurement, using another correction weight is recommended. However, when the result is not better (or is even worse), additional correction runs are meaningless.

## Dual Plane Balancing

### Initial Run

The screen is divided into two parts. The left part corresponds to point A measurements and plane 1 results, the right part corresponds to point B measurements and plane 2 results.

If you only use one sensor ([Point A Channel](#), [Point B Channel](#) are the same), then only one part is active. The non-active part is grey and shows a blurry image. Mount the sensor to the active plane point and start the measurement. Use the **Right / Left** arrow button to move the active focus.

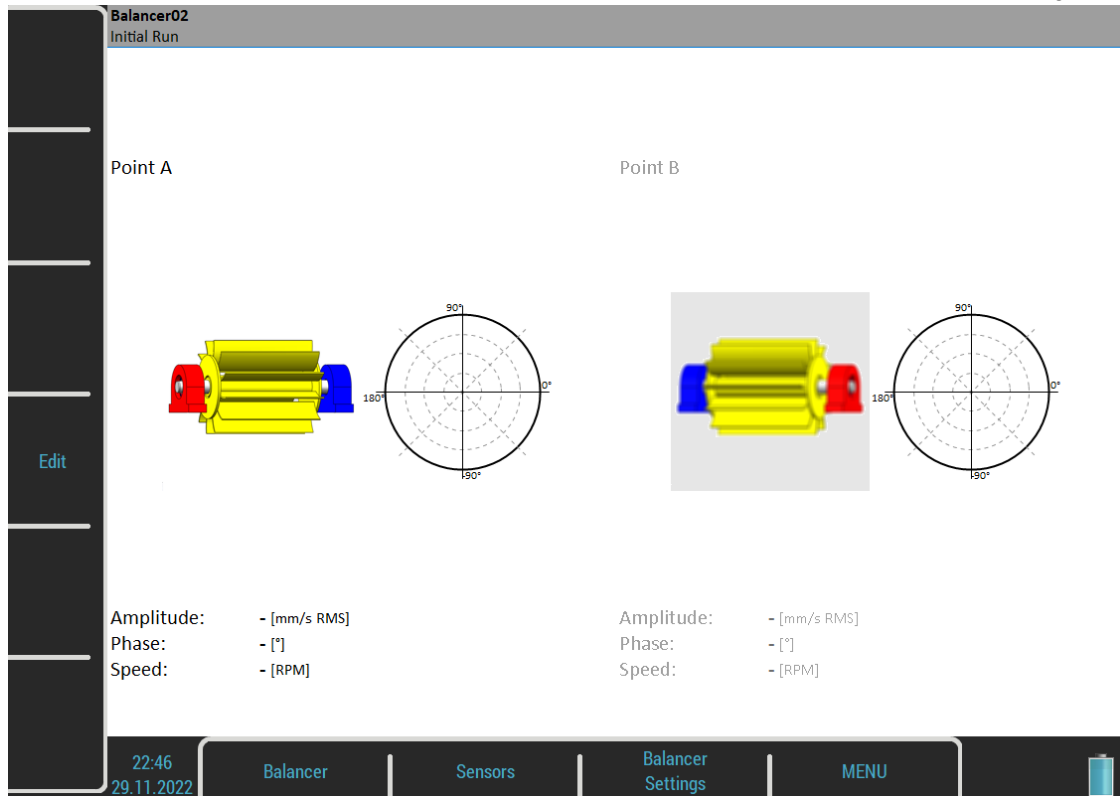

You can make both points measurements together with two sensors (set the [Point A Channel](#), [Point B Channel](#) to different values). Then the screen should look like the next picture.

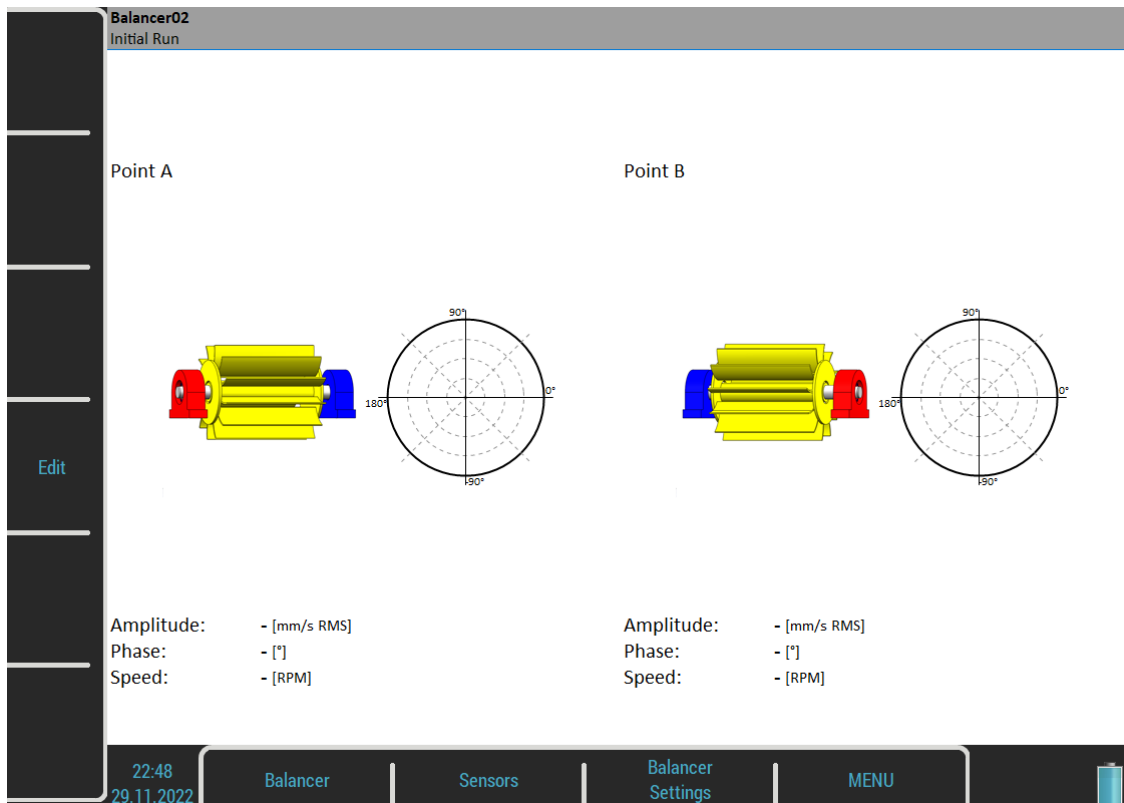

The red bearing house is the recommended point for mounting the sensor, but you can use any other place which is suitable for measurements. The polar graph is prepared to display the measured values. Push the **Enter/Start** button and a measurement will be taken. Alternatively, you may press the **Edit** button and enter all values manually (balancing calculator function).

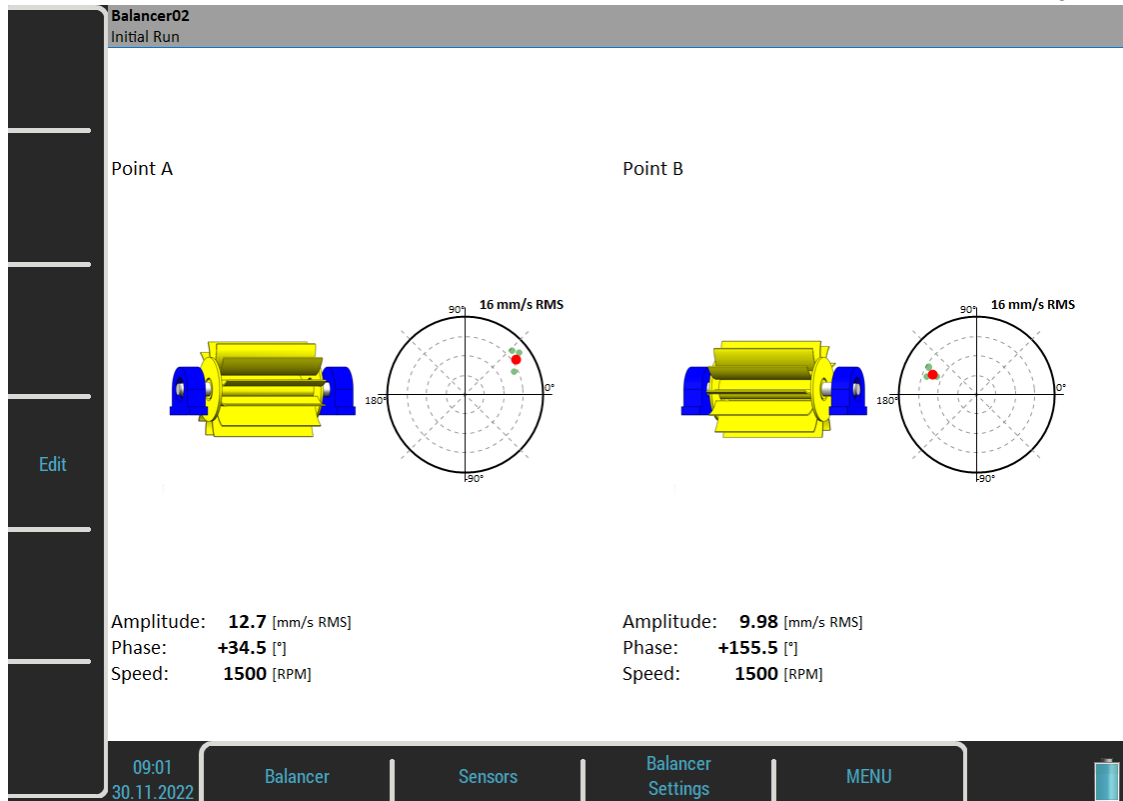

The red dot in the polar graph shows the current amplitude and phase in the complex plane. Smaller green dots show all values during the measurement process when the [Meas Mode](#) is set as **online meter**. Press the **Down** arrow to move to the next screen.

### Trial Run 1

It is similar to the single plane balancing, only two trial weights must be subsequently mounted to two planes. If you know the *dynamic factor*, you can enter all 4 values manually and you do not need to measure trial runs. See more details about dynamic factor in [Single Plane Balancing / Trial Run](#).

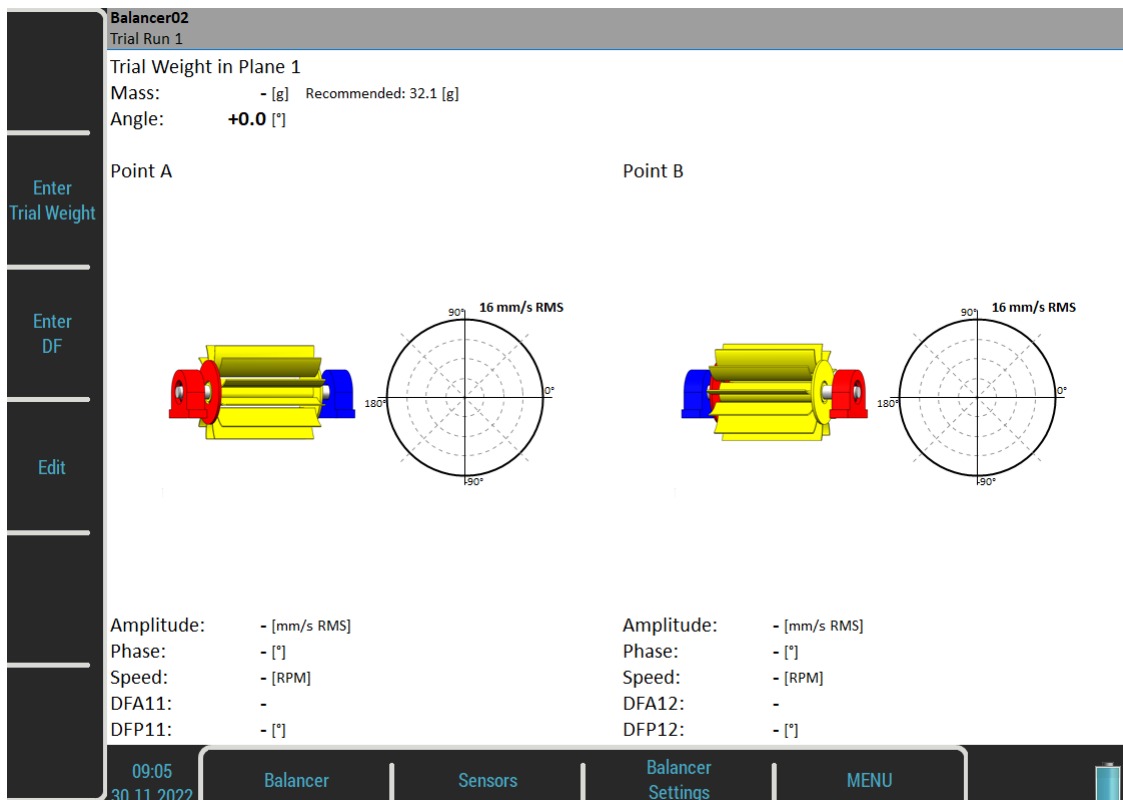

The plane for trial weight mounting is highlighted by a red disc. See the [Single Plane Balancing / Trial Run](#) for more details about trial weight mounting.

Put the trial weight to the plane 1 and take the measurements for both points.

After both points measurements are taken, you should resolve the trial weight according to the [Basic Settings / Remove Trial Weight \(Plane 1\)](#).

If **Remove Trial Weight** is set to **yes**, the following question will appear:

Temporarily keep trial weight in plane 1 also during measurement with trial weight in plane 2?

If you answer *No*, then you must remove the trial weight as expected. However, you can answer *Yes* and keep the trial weight on plane 1 also during measurement with trial weight in plane 2. This can be useful when you want to use the trial weight as the zero mark for correction weights mounting.

If **Remove Trial Weight** is set as **no**, the following notification will appear.

Keep trial weight in plane 1!

After confirming a message, you can check the measured values on the Trial Run 1 screen.

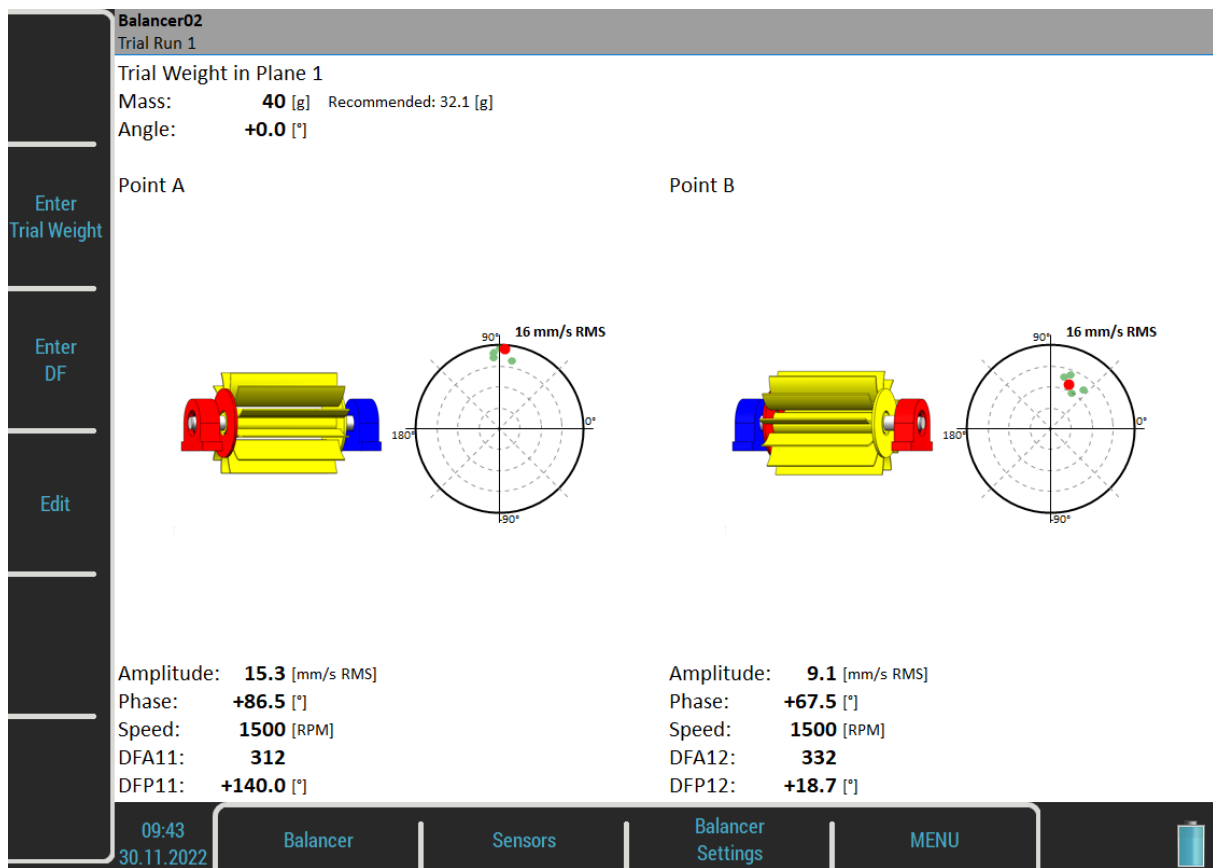



**Trial Run 2**

**Balancer02**  
Trial Run 2

Trial Weight in Plane 2  
 Mass: - [g] Recommended: 32.1 [g]  
 Angle: **+0.0** [°]

Point A

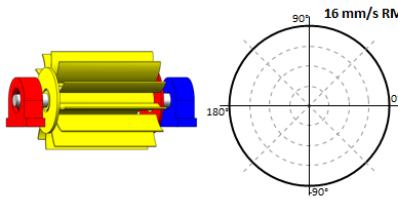

Point B

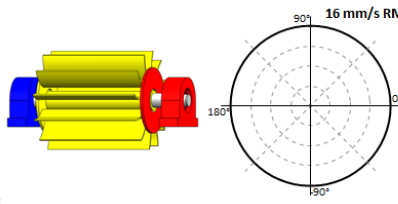

Amplitude: - [mm/s RMS]  
 Phase: - [°]  
 Speed: - [RPM]  
 DFA21: -  
 DFP21: - [°]

Amplitude: - [mm/s RMS]  
 Phase: - [°]  
 Speed: - [RPM]  
 DFA22: -  
 DFP22: - [°]

09:51  
30.11.2022
Balancer
Sensors
Balancer Settings
MENU

We have to take the same two measurements with the trial weight in the plane 2. The screen for those measurement looks similar to the previous screen. Only the red disc is in the plane 2. Enter the trial weight values and put the trial weight into the plane 2. Take the measurement on both points.

**Balancer02**  
Trial Run 2

Trial Weight in Plane 2  
 Mass: **40** [g] Recommended: 32.1 [g]  
 Angle: **+0.0** [°]

Point A

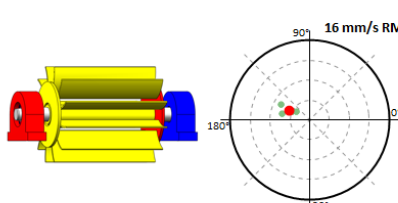

Point B

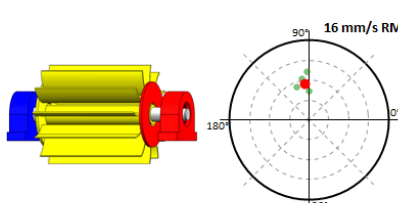

Amplitude: **4.5** [mm/s RMS]  
 Phase: **+156.0** [°]  
 Speed: **1500** [RPM]  
 DFA21: **358**  
 DFP21: **-110.7** [°]

Amplitude: **7.2** [mm/s RMS]  
 Phase: **+97.0** [°]  
 Speed: **1500** [RPM]  
 DFA22: **114**  
 DFP22: **-163.9** [°]

09:58  
30.11.2022
Balancer
Sensors
Balancer Settings
MENU

### Result

After entering the result screen, you will be asked to keep or remove the trial weight from the plane 2 according to [Basic Settings](#) / [Remove Trial Weight \(Plane 2\)](#). In case you temporarily kept the trial weight, you'll be prompted to remove it now.

Remove trial weight from plane 1!  
Remove trial weight from plane 2!

Don't forget to remove the trial weights if needed. However, you can use them as the zero mark first and remove them after the correction weights mounting.

The result screen looks similar to the one in the single plane balancing. It contains correction weights suggestions for both planes. See more details about correction weights mounting in [Single Plane Balancing](#) / [Result](#). The initial and residual imbalances and qualities are calculated for the whole machine, not for each plane separately.

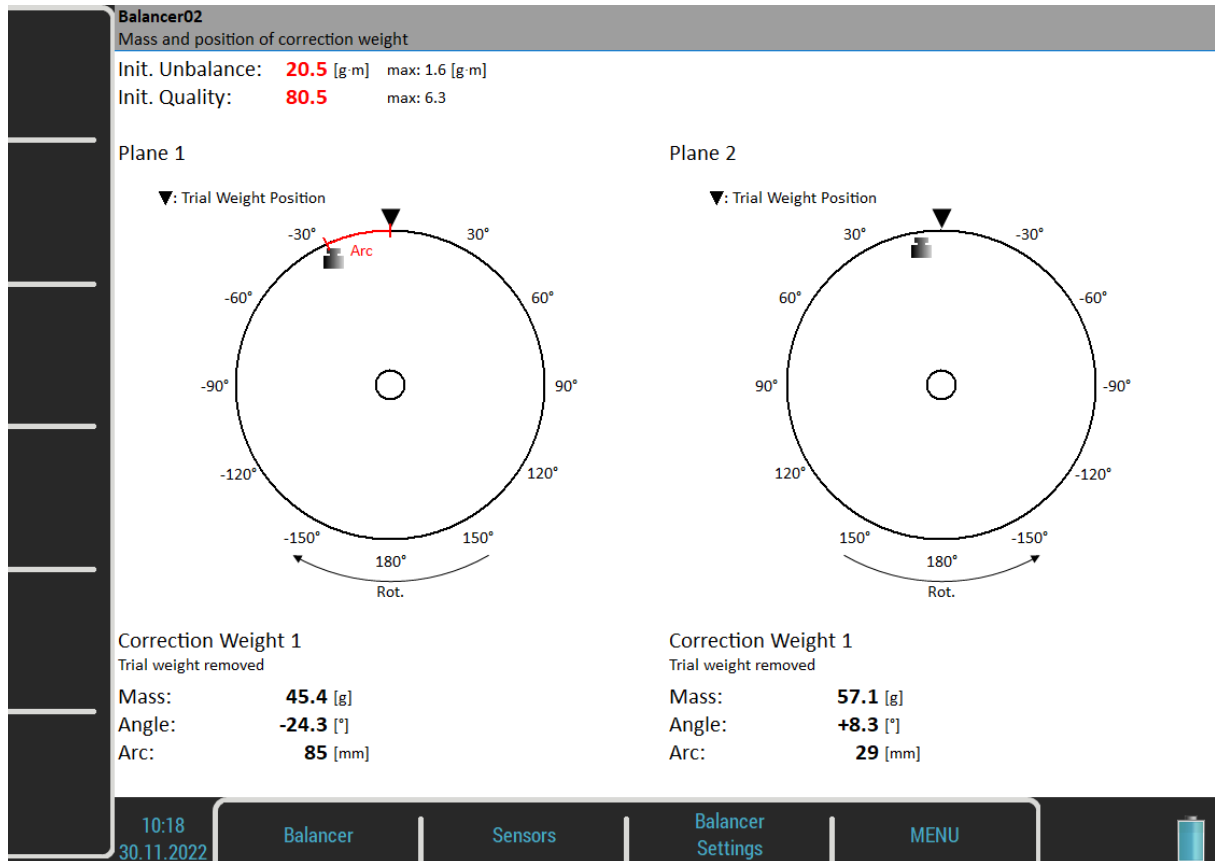

### Correction Run

See [Single Plane Balancing](#) / [Correction Run](#) for more details.

**Balancer02**  
Correction Run 1

Point A

Amplitude: **0.5** [mm/s RMS]  
Phase: **+11.0** [°]  
Speed: **1500** [RPM]  
Initial Run: **12.7** [mm/s RMS]  
Effect: **96.1** [%]

Point B

Amplitude: **0.3** [mm/s RMS]  
Phase: **+59.0** [°]  
Speed: **1500** [RPM]  
Initial Run: **9.98** [mm/s RMS]  
Effect: **97** [%]

10:28 30.11.2022

Balancer   Sensors   Balancer Settings   MENU

**Balancer02**  
Mass and position of correction weight

Res. Unbalance: **0.704** [g·m]   max: 1.6 [g·m]  
Res. Quality: **2.77**   max: 6.3

Plane 1

▼: Trial Weight Position

Correction Weight 2  
Trial weight removed

Mass: **1.18** [g]  
Angle: **-97.3** [°]  
Arc: **340** [mm]

Plane 2

▼: Trial Weight Position

Correction Weight 2  
Trial weight removed

Mass: **2.34** [g]  
Angle: **-44.9** [°]  
Arc: **157** [mm]

10:31 30.11.2022

Balancer   Sensors   Balancer Settings   MENU

## Balancing Errors

Balancing errors and warnings can occur during the job.

### The effect of trial weight is low

This message informs you that the effect of the trial weight is low.

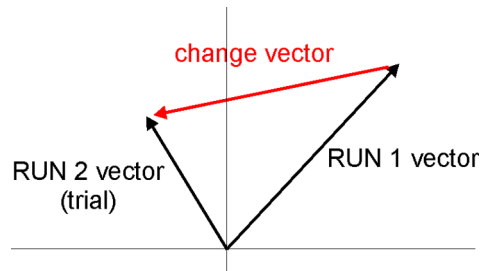

The percentual value is derived from ratio of the amplitude of change vector to the amplitude of Run1 vector.

A warning is displayed when the change is less than 20% but bigger than 1%. You can continue with balancing after this warning and use these values.

An error is displayed when the change is less than 1%. You cannot continue with balancing after this error, because such a small change is not acceptable. You could get incorrect results.

### ***Unacceptable speed change***

The balancing procedure must be executed on a constant speed during all runs. The balancing speed is checked and when it changes by more than 5%, the error occurs.

### ***Unstable phase***

The phase stability can be checked only if averaging is used ([Basic Settings](#) / [Avg](#)). If the phase during the averaging changes, it probably means that the unbalance is not the main problem of the machine. Thus, the error is indicated and the balancing procedure stops.

## ***Balancer Menu***

The next functions are available for an opened project. Push the **Balancer** button and the menu with the additional functions appears.

### ***Balancing Report***

Create a balancing report in rtf format and save it to the *VA5\_DISC* to the *VA4balancer\_protocol* folder.

### ***Balancing Report (csv)***

Simple format.

### ***Balancing Vectors***

Create a drawing of the amplitude / phase vector development during the balancing process. The drawing is also included to the balancing report.

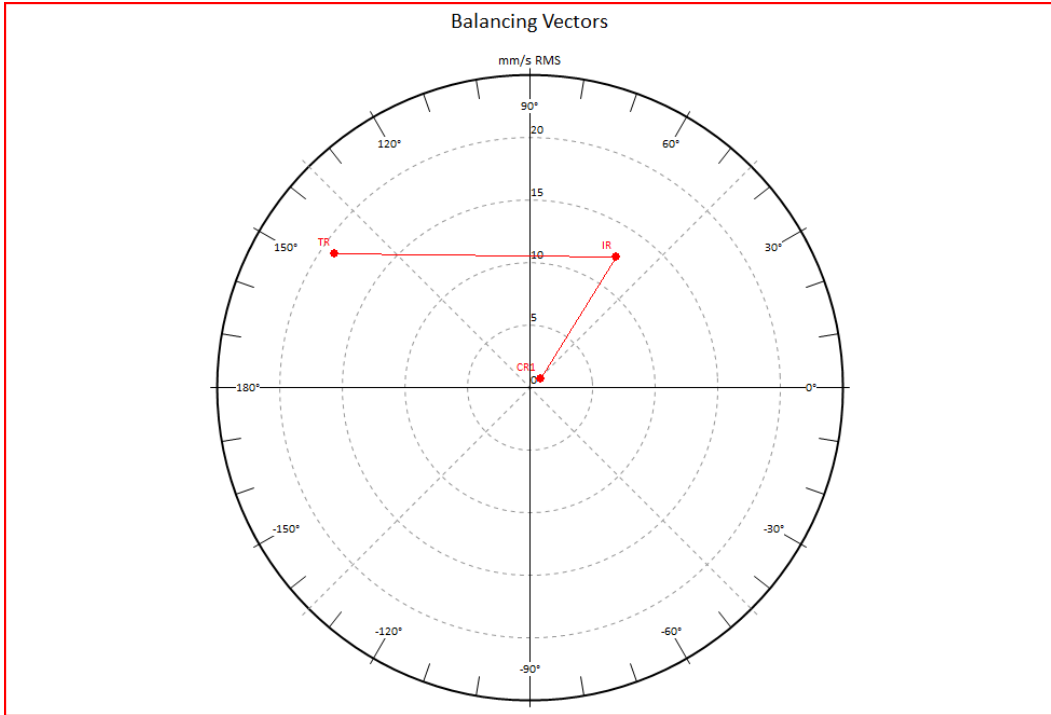

- IR** Initial Run
- TR** Trial Run
- CR** Correction Run

### Total Mass

Displays the total balancing mass. It is a vector sum of all masses mounted to the rotor (all correction weights and kept trial weights).

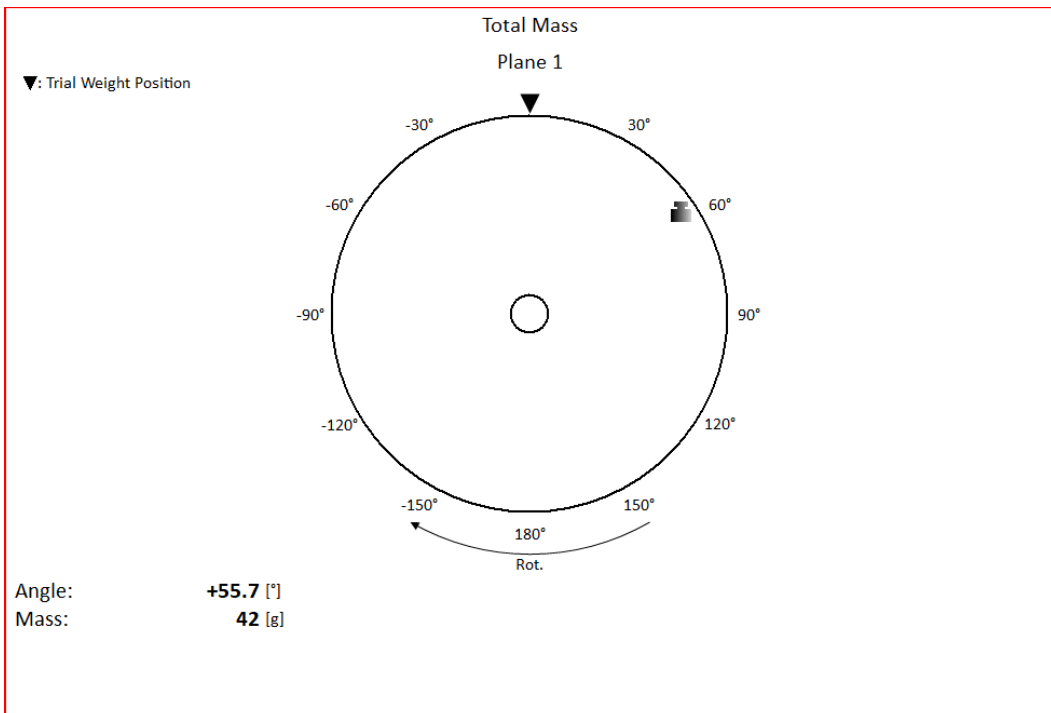

## **Advanced Balancer**

This module supports an advanced balancing process. It enables balancing on up to eight planes. Moreover, it enables the number of measurement points to be greater than the number of planes. This is useful in situations when not all planes are accessible for trial mass mounting.

### **Project**

Like in the previous [Balancer](#) module, the balancing job is organized as a project. The project contains all entered parameters of the balancing procedure and all measured or entered data.

The typical balancing job scheme looks like in the [Balancer](#) module:

- Create new project.
- Enter balancing parameters (type of machine, number of planes etc.).
- Initial measurement of the vibration amplitude and phase on the required measurement points.
- Put trial weight on the rotor. Step by step to all planes.
- Trial weight response measurement. Step by step to all planes.
- Put correction weights on all planes.
- Check of effect (success).
- Trim measurements for additional weights and better results.

Every step is displayed in one screen. The movement between screens is provided by **Up / Down** arrows.

**Attention!** When you return back in the job screens and you take a repeated measurement or enter a new value, then the measured data will be erased in all screens after the current screen. The reason is simple. The parameters in the next screen are derived from the previous screen. When you repeat the measurement, you change these parameters. That is why all following screen parameters must be removed and you have to make all necessary measurements again.

### **Project List**

The list of saved projects opens when you enter the module. The list is empty if you have no saved projects yet. The modification time stamp of the selected project is displayed in the status bar in the bottom right corner.

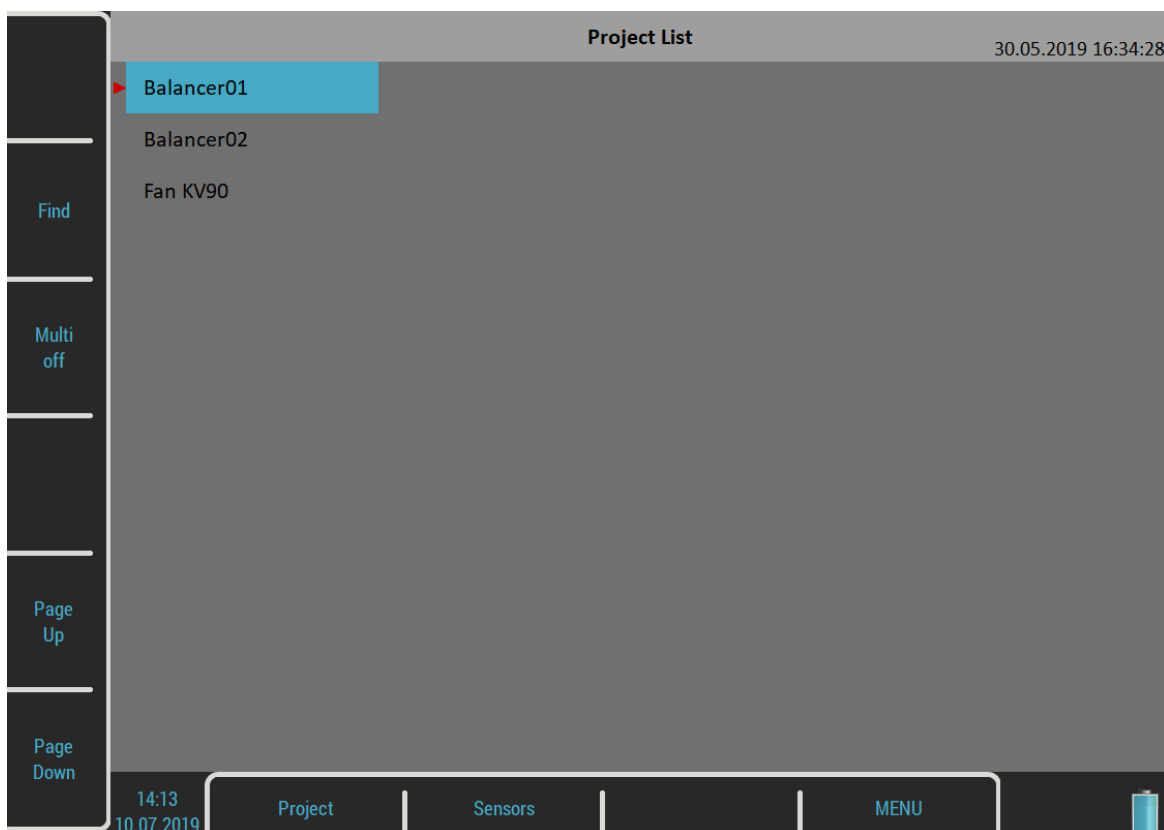

## Project Menu

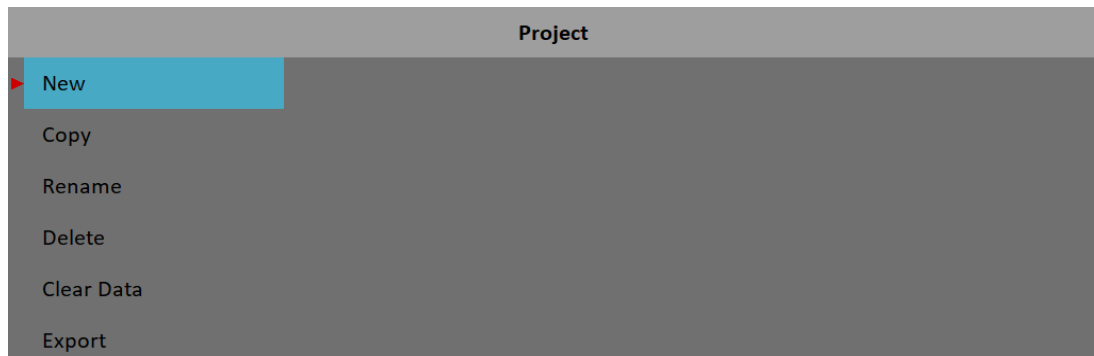

### ***New***

Creates a new project with default properties.

### ***Copy***

Creates a new project as a copy of the selected project. Only the header data are saved. No measured data are saved.

### ***Rename***

Renames the selected project. The project with the old name does not exist anymore.

### ***Delete***

Deletes the selected project.

### ***Clear Data***

Erase all measured data, only the project header remains.

### ***Export***

Exports the selected project to *VA5\_DISC*.

## ***Balancer Settings***

Settings menus automatically open when you open a project which has no data yet. Later, you may open the menus using the **Balancer Settings** button. There are two separate menus under this button, [Basic Settings](#) and [Units Settings](#).

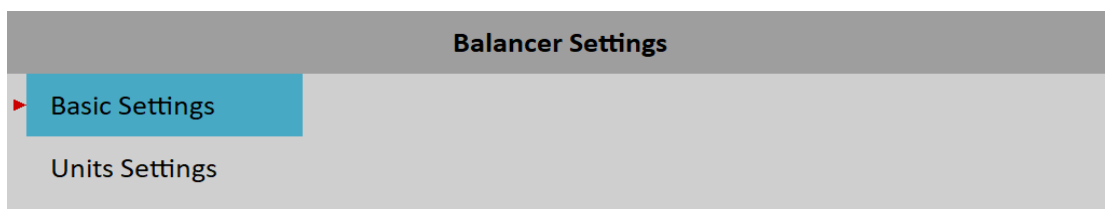

## Basic Settings

| Basic Settings              |                         |
|-----------------------------|-------------------------|
| ▶ Planes                    | 1                       |
| Points                      | 1                       |
| Meas Mode                   | single                  |
| Avg                         | off                     |
| Resolution                  | speed / 4<br>t = 4 revs |
| Point A - Channel           | 1                       |
| Plane 1 - Remove Trial Mass | yes                     |
| Save                        |                         |

### Planes

Number of balancing planes.

**Note!** Planes are marked with numbers, Plane 1, Plane 2 etc.

### Points

Number of measurement points. Must be greater or equal to the number of balancing planes.

**Note!** Points are marked with letter, Point A, Point B etc.

### Meas Mode

**single, online meter**

When you start a measurement process by pushing *Enter*, then only one value can be taken (**single**) or the continual measurement values could be displayed (**online meter**). In **online meter** mode you can look at more values and evaluate how they change in time. You need to stop the measurement by pushing *Escape*, when the value you want to see is displayed.

### Avg

The averaging of more than one measured value is available

### Resolution

It's the aps measurement resolution described in [Analyzer](#) / [Edit Measurement](#) / [Resolution](#).

### Point A - Channel, Point B - Channel,...

The AC input for each point.

**Note!** The marking of the measurement points as A and B only has a symbolic meaning. It has no relation to the balancing planes 1, 2 and to the balancing computational procedure. You can mark any point as A and any other as B and so on.

Since it is possible to use up to eight measurement points and the instrument contains only four AC inputs or you can use even less sensors, you may sometimes need to use one AC input for more points. You can setup the same channel repeatedly for more points. Then, the points are divided into groups, so no AC input is used twice during one measurement process. A point where the channel is already used in a previous group is the beginning of a new group.



**E.g.**, You want to use six measurement points and you only have two sensors connected to AC1 and AC2. You enter:

- Point A - Channel: 1
- Point B - Channel: 2
- Point C - Channel: 1
- Point D - Channel: 2
- Point E - Channel: 1
- Point F - Channel: 2

The points will be grouped as A with B as first group, C with D as the next group and E with F as the last group.

In a run screen which will be explained later, the group of points which is going to be measured is marked by an asterisk \*. Points A and B on the next picture are to be measured after you push the *Enter* button.

| Point                | A* | B* | C | D | E | F |
|----------------------|----|----|---|---|---|---|
| Channel              | 1  | 2  | 1 | 2 | 1 | 2 |
| Amplitude [mm/s 0-P] |    |    |   |   |   |   |
| Phase [°]            |    |    |   |   |   |   |

The marked group is automatically switched after the measurement is completed. You can also switch it manually by pressing the **Shift (\*)** button.

|                      | Point | A | B | C* | D* | E | F |
|----------------------|-------|---|---|----|----|---|---|
| Channel              |       | 1 | 2 | 1  | 2  | 1 | 2 |
| Amplitude [mm/s 0-P] |       |   |   |    |    |   |   |
| Phase [°]            |       |   |   |    |    |   |   |

Edit

Shift (\*)

**Note!** You can change the channel numbers anytime during the balancing procedure by tapping the channel display. You don't need to open the menu.

**Note!** The number of channels can be set as **off**. Then, this point is not included to any group and therefore is not measured.

***Plane 1 – Remove Trial Mass, Plane 2 – Remove Trial Mass, ...***

**yes, no**

You can decide if you remove a trial mass on each plane or not.

**Units Settings**

| Units Settings |      |
|----------------|------|
| ▶ Amplitude    | mm/s |
| Detect Type    | RMS  |
| Speed          | RPM  |
| Mass           | g    |
| Save           |      |

## **Amplitude**

Selection from units available for the used sensor

## **Detect Type**

**RMS, 0-P, P-P**

Detect type for amplitude value

**Note!** This value is the same as the global value defined in [MENU / SETTINGS / Spectrum Settings / Detect Type](#) until you change it here. That means, if you change the global value, it will also be changed here. This will stop after the first time you enter a value here.

## **Speed**

Selection from available units for speed

## **Mass**

Selection of unit for mass

## **Balancing Procedure**

Let's describe the balancing procedure on an example with two planes and four points, which should clarify the procedure for any possible combination of number of planes and points in general.

Create a new project using menu [Project / New](#). Enter the name, e.g., **Bal2x4**.

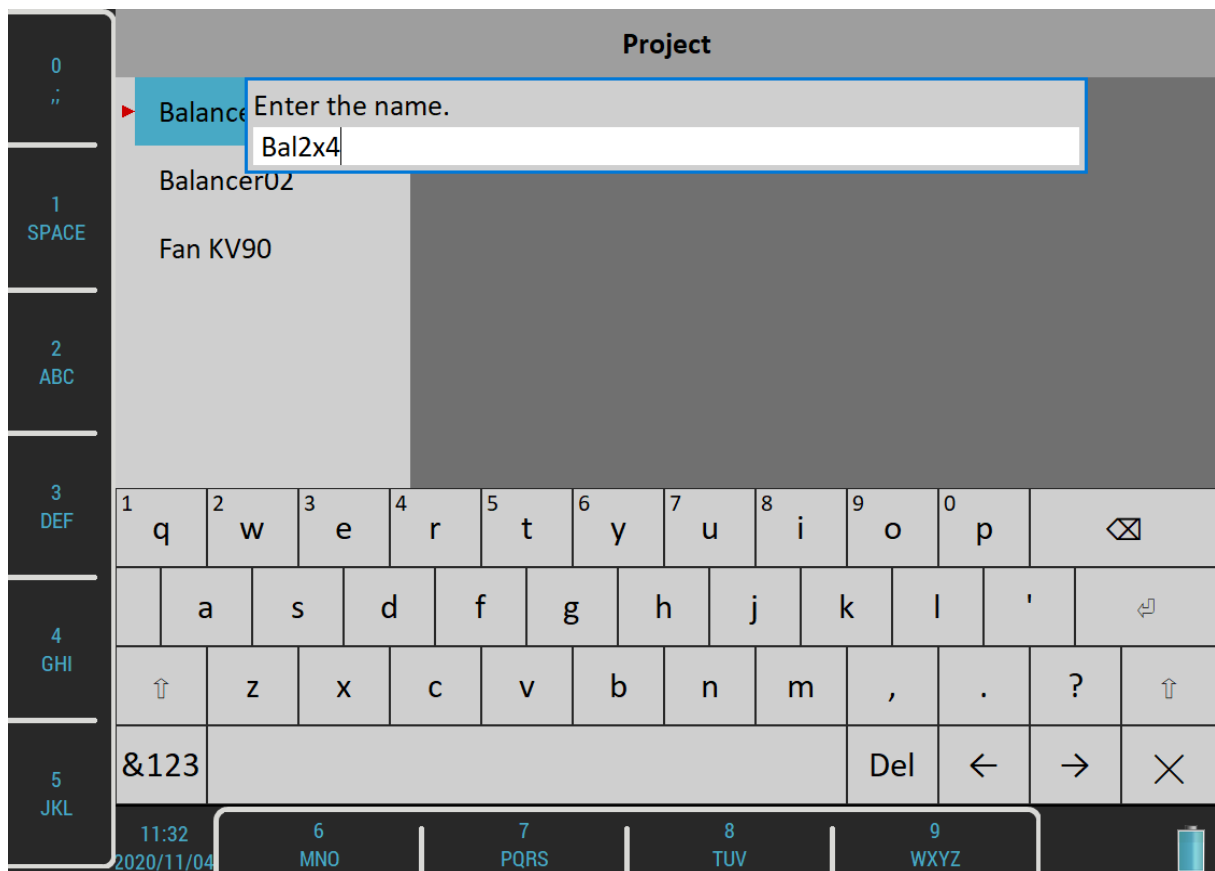

Open the project. Since the project has no data yet, the [Basic Settings](#) menu appears. In the menu, enter the [Planes](#) value as 2 and the [Points](#) value as 4. Let's suppose we are using two AC sensors mounted on inputs AC1 and AC2. Therefore, enter the points channels as 1 for Point A and Point C and as 2 for Point B and Point D. Other values can stay on defaults.

| Basic Settings              |                         |
|-----------------------------|-------------------------|
| Planes                      | 2                       |
| Points                      | 4                       |
| Meas Mode                   | single                  |
| Avg                         | off                     |
| Resolution                  | speed / 4<br>t = 4 revs |
| Point A - Channel           | 1                       |
| Point B - Channel           | 2                       |
| Point C - Channel           | 1                       |
| Point D - Channel           | 2                       |
| Plane 1 - Remove Trial Mass | yes                     |
| Plane 2 - Remove Trial Mass | yes                     |
| Save                        |                         |

Confirm the [Basic Settings](#) menu. The [Units Settings](#) menu appears. Let's confirm the default values.

| Units Settings |      |
|----------------|------|
| Amplitude      | mm/s |
| Detect Type    | RMS  |
| Speed          | RPM  |
| Mass           | g    |
| Save           |      |

### ***Initial Run***

After we have entered and confirmed all parameters, the ***Initial Run*** screen appears.

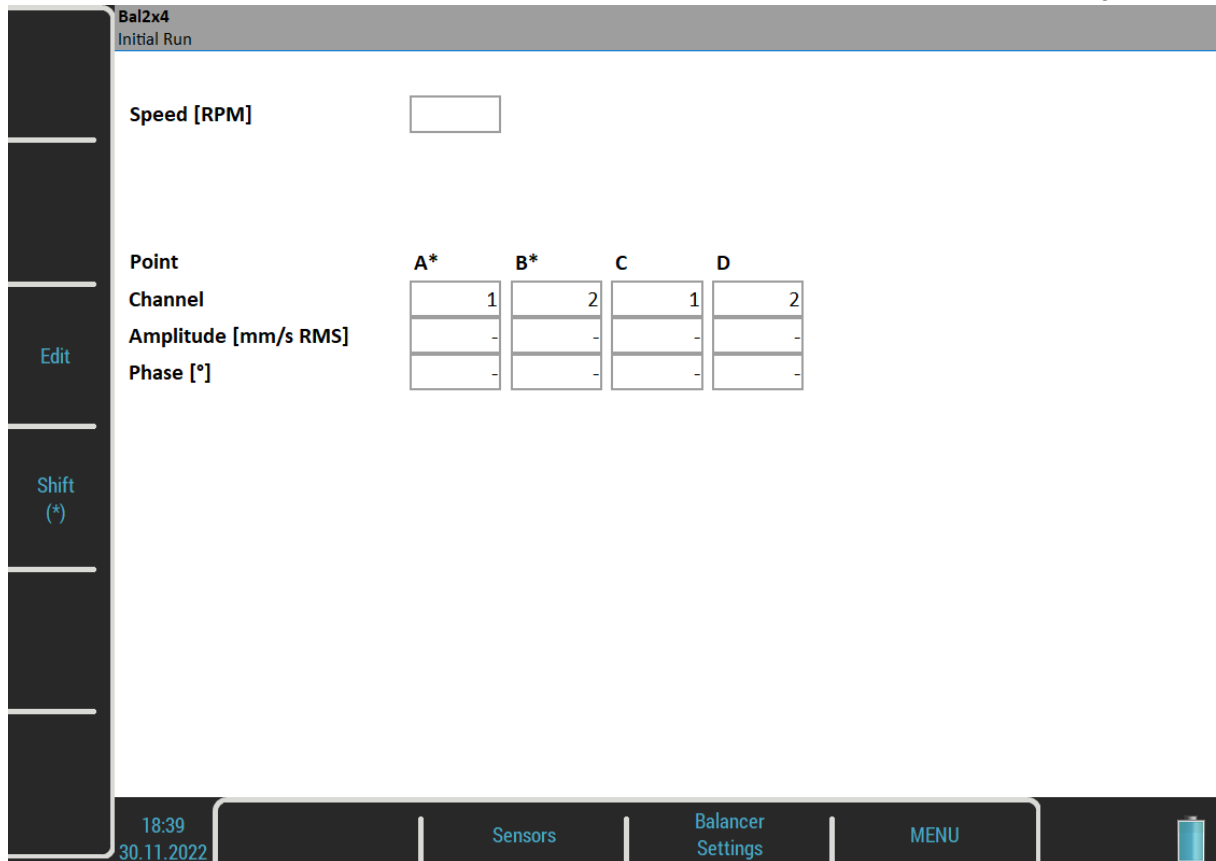

Now, you need to make the **Initial measurement**. Points A and B are marked to be measured as has been described in the [Basic Settings / Point A - Channel, Point B - Channel, ....](#). Remember to mount sensors to the correct measurement points on the machine. Start the measurement process on marked channels by pressing the **Enter/Start** button.

|                      |       |        |    |    |
|----------------------|-------|--------|----|----|
| Speed [RPM]          | 3000  |        |    |    |
| Point                | A     | B      | C* | D* |
| Channel              | 1     | 2      | 1  | 2  |
| Amplitude [mm/s RMS] | 9.3   | 5.8    | -  | -  |
| Phase [°]            | +58.0 | -175.0 | -  | -  |

After you have finished the measurement on the marked points, marks automatically shift to the next points. Remount the sensors and start the measurement again.

|                      |       |        |        |       |
|----------------------|-------|--------|--------|-------|
| Speed [RPM]          | 3000  |        |        |       |
| Point                | A     | B      | C*     | D*    |
| Channel              | 1     | 2      | 1      | 2     |
| Amplitude [mm/s RMS] | 9.3   | 5.8    | 5      | 3.9   |
| Phase [°]            | +58.0 | -175.0 | -104.0 | +12.0 |

Now, all measurements of the **Initial Run** are completed. Marked points stay as they are, so you can continue without sensor remounting on the next run. You can still change the marked points anytime using the **Shift (\*)** button.

**Note!** The speed value is displayed only on the first screen. However, the speed is checked during all measurements and when it differs, the balancing procedure is stopped.

**Note!** Values don't need to be measured. You can push the **Edit** button and enter all values manually (balancing calculator function). You can also start the value editing by tapping on any value display. Entries continue automatically on other displays until the last value is entered or the *Esc* key is pressed.

**Note!** You can change the channel numbers anytime during the balancing procedure by tapping the channel display.

Press the **Down** button to continue to the next run.

### Trial Runs

Bal2x4  
Trial Run 1

**Trial Weight in Plane 1**

Mass [g]

Angle [°]

Remove Trial Weight

**Point**

|                      | A                              | B                              | C*                             | D*                             |
|----------------------|--------------------------------|--------------------------------|--------------------------------|--------------------------------|
| Channel              | <input type="text" value="1"/> | <input type="text" value="2"/> | <input type="text" value="1"/> | <input type="text" value="2"/> |
| Amplitude [mm/s RMS] | <input type="text" value="-"/> | <input type="text" value="-"/> | <input type="text" value="-"/> | <input type="text" value="-"/> |
| Phase [°]            | <input type="text" value="-"/> | <input type="text" value="-"/> | <input type="text" value="-"/> | <input type="text" value="-"/> |

18:49  
30.11.2022

Sensors Balancer Settings MENU

The procedure continues with measurements with trial mass on all planes. First, enter the trial weight mass and angle by pushing the **Enter Trial Weight** button or tapping the *Trial Mass* display. See [Balancer / Single Plane Balancing / Trial Run](#) for more details about trial weight mounting.

Remember to mount the weight to the appropriate plane. By default, you don't need to remount sensors, because marked points have stayed as you used them in the end of the previous run. However, you can remount them and push the **Shift (\*)** button if you need. Take all measurements gradually the same way as on [Initial Run](#).

**Note!** You may also change the *Remove Trial Mass* value by tapping the display. You must do it before the measurement.

## Trial Weight in Plane 1

|                     |      |
|---------------------|------|
| Mass [g]            | 100  |
| Angle [°]           | +0.0 |
| Remove Trial Weight | yes  |

| Point                | A*    | B*     | C     | D     |
|----------------------|-------|--------|-------|-------|
| Channel              | 1     | 2      | 1     | 2     |
| Amplitude [mm/s RMS] | 3.1   | 1.5    | 3     | 7.8   |
| Phase [°]            | +59.0 | -162.0 | +54.6 | +15.3 |

After all points measurements are taken, you should resolve the trial weight according to the **Remove Trial Weight** setup.

In case the *Remove Trial Weight* is set as **yes**, the next question will appear:

Temporarily keep trial weight in plane 1 also during measurements with trial weight in next planes?

If you answer *No*, then you must remove the trial weight as expected. However, you can answer *Yes* and keep the trial weight on the plane 1 also during measurements with trial weight in the next planes. This can be useful when you want to use the trial weight as the zero mark for the correction weights mounting.

In case the *Remove Trial Weight* is set as **no**, the next notification will appear.

Keep trial weight in plane 1!

Push the *Down* button. Repeat the same steps for all planes (once more in our case of two planes).

## Trial Weight in Plane 2

|                     |      |
|---------------------|------|
| Mass [g]            | 100  |
| Angle [°]           | +0.0 |
| Remove Trial Weight | yes  |

| Point                | A*     | B*    | C     | D     |
|----------------------|--------|-------|-------|-------|
| Channel              | 1      | 2     | 1     | 2     |
| Amplitude [mm/s RMS] | 3.1    | 4.3   | 1.3   | 4.1   |
| Phase [°]            | -162.0 | +11.6 | +55.6 | -64.0 |

Now, you have done all needed measurements for the correction weight calculation.

### **Result Screen (Option: the number of points is greater than the number of planes)**

After entering the result screen, you will be asked to keep or remove the trial weight from the last trial plane according to its *Remove Trial Weight* setup. In case you temporarily kept a trial weight on any of the previous planes, you'll be prompted to remove it now.

Remove trial weight from plane 1!  
Remove trial weight from plane 2!

Don't forget to remove the trial weights if needed. However, you can use them as a zero mark first and remove them after the correction weights mounting.

| Bal2x4<br>Mass and position of correction weight |       |       |      |      |
|--|-------|-------|------|------|
| Plane  | 1     | 2     |      |      |
| Mass L2 [g]                                      | 74.7  | 70.7  |      |      |
| Angle L2 [°]                                     | +14.0 | -13.7 |      |      |
| Mass L $\infty$ [g]                              | 77    | 70    |      |      |
| Angle L $\infty$ [°]                             | +16.3 | -13.0 |      |      |
| <b>Residual Vibrations [mm/s RMS]</b>            |       |       |      |      |
| Point  | A     | B     | C    | D    |
| L2   | 1.79  | 1.49  | 1.32 | 1.51 |
| L2 5%  | 2.23  | 1.86  | 1.68 | 1.94 |
| L2 10%   | 2.67  | 2.23  | 2.03 | 2.38 |
| L2 20%   | 3.54  | 2.96  | 2.74 | 3.24 |
| L $\infty$                                       | 1.56  | 1.56  | 1.56 | 1.56 |
| L $\infty$ 5%                                    | 2     | 1.93  | 1.92 | 1.99 |
| L $\infty$ 10%                                   | 2.44  | 2.3   | 2.28 | 2.42 |
| L $\infty$ 20%                                   | 3.32  | 3.04  | 3.01 | 3.29 |

19:51  
30.11.2022

Sensors Balancer Settings MENU

In case the number of points is greater than the number of planes, some residual vibrations remain on each point. You are not able to get zero on all points. There could be many ways of how to optimize these residual vibrations. However, there are two ways which are meaningful. You can minimize the L2 or L $\infty$  norm of the vector of residual vibrations.

Let's write the vector of residual vibrations as:

$$\text{res} = (\text{res}_1, \text{res}_2, \dots, \text{res}_{\text{number of points}}),$$

then the L2 norm of the vector of residual vibrations is defined as:

$$\|\text{res}\|_2 = \sqrt{\text{res}_1^2 + \text{res}_2^2 + \dots + \text{res}_{\text{number of points}}^2}$$

and the L $\infty$  norm of the vector of residual vibrations is defined as:

$$\|\text{res}\|_\infty = \max(|\text{res}_1|, |\text{res}_2|, \dots, |\text{res}_{\text{number of points}}|)$$

Then, minimizing the L2 norm means that you want the sum of squares of residual vibrations to be as low as possible. In other words, this is the least squares method. Minimizing the L $\infty$  norm means you want the maximum amplitude of all residual vibrations to be as low as possible.

The instrument offers you both results with the smallest L2 and L $\infty$  norm. You can choose which is more convenient to you. The weights and positions of the resulting correction weights for both norms for each plane are displayed in the upper part of the screen.

| Plane                | 1     | 2     |
|----------------------|-------|-------|
| Mass L2 [g]          | 74.7  | 70.7  |
| Angle L2 [°]         | +14.0 | -13.7 |
| Mass L $\infty$ [g]  | 77    | 70    |
| Angle L $\infty$ [°] | +16.3 | -13.0 |

The residual vibrations for both norms for each point are displayed in the lower part of the screen.

**Residual Vibrations [mm/s RMS]**

| Point          | A    | B    | C    | D    |
|----------------|------|------|------|------|
| L2             | 1.79 | 1.49 | 1.32 | 1.51 |
| L2 5%          | 2.23 | 1.86 | 1.68 | 1.94 |
| L2 10%         | 2.67 | 2.23 | 2.03 | 2.38 |
| L2 20%         | 3.54 | 2.96 | 2.74 | 3.24 |
| L $\infty$     | 1.56 | 1.56 | 1.56 | 1.56 |
| L $\infty$ 5%  | 2    | 1.93 | 1.92 | 1.99 |
| L $\infty$ 10% | 2.44 | 2.3  | 2.28 | 2.42 |
| L $\infty$ 20% | 3.32 | 3.04 | 3.01 | 3.29 |

The L2 line shows you the residual vibrations of the L2 result. The L $\infty$  line shows you the residual vibrations for the L $\infty$  result.

Moreover, there are three more lines for each norm. They represent residual vibrations in case you mount the balancing mass with 5%, 10% or 20% inaccuracy. This gives you the information about the sensitivity of the residual vibrations to the mounting position. If the values on the next lines increase a lot, you can say that the system is very sensitive to the balancing mass position and you should be careful while mounting it.

**Note!** See [Global Settings](#) / [Angles Counting](#) and [Balancer](#) / [Single Plane Balancing](#) / [Result](#) for more details about correction weight angles.

**Result Screen (Option: number of points equals number of planes)**

Bal2x2  
Mass and position of correction weight

| Plane     | 1    | 2    |
|-----------|------|------|
| Mass [g]  | 98.2 | 102  |
| Angle [°] | -1.2 | +4.0 |

Residual Vibrations [mm/s RMS]

| Point | A    | B    |
|-------|------|------|
| 5%    | 2.84 | 1.12 |
| 10%   | 5.68 | 2.24 |
| 20%   | 11.4 | 4.48 |

19:57  
30.11.2022

Sensors      Balancer Settings      MENU

In case the number of points equals the number of planes, there are of course no residual vibrations. You don't need to minimize them because they all are zero. Therefore, there is just one result. However, it still makes sense to show the residual vibrations representing the sensitivity to the balancing mass position.

**Correction Run**

When the mass or masses are mounted to the planes you should take one more measurement where you check the effect of the balancing mass. Push the *Down* button and perform the measurement in a known manner.



Bal2x4  
Correction Run 1

| Point                | A*    | B*     | C     | D     |
|----------------------|-------|--------|-------|-------|
| Channel              | 1     | 2      | 1     | 2     |
| Amplitude [mm/s RMS] | 2.1   | 1.7    | 1.5   | 1     |
| Phase [°]            | +60.0 | +125.0 | +59.0 | +99.0 |

19:59  
30.11.2022

Sensors

Balancer  
Settings

MENU

You can continue (push the *Down* button) with the job when you are not satisfied with the results. These next steps do not require trial mass measurements. After each measurement, using another correction weights is recommended. However, when the result is not better (or is even worse), the next correction runs are meaningless.

### **Balancing Errors**

Errors and warnings can occur during the balancing job as described in the [Balancing Errors](#) chapter in [Balancer](#) module.

### **Balancer Menu**

The next functions are available for opened project. Push the **Balancer** button and the menu with the additional functions appears.

### **Balancing Report**

Create a balancing report in txt format and save it to the *VA5\_DISC* to the *VA4balancer\_protocol* folder.

## **FASIT**

The FASIT means the **FA**ult **S**ource **I**dentification **T**ool. This mode should help beginners to determine the machine condition or bearing faults.

### ***Adash Vibration Limits***

Because there are a lot of different types of machines, it is impossible to determine the critical limits of vibrations for a wide range of machines. Its reliability would be low. It could happen, you will repair a machine, which do not require it. The standards should rather be determined for a narrow range of machines.

The instrument uses the Adash limit values. These limits are not rewritten from any existing standard. It's a result of many years of Adash engineering team experiences. It's difficult to invent a critical value definition which would be simple (that means not many parameters such as speed, power, bearing type, machine type and so on) and reliable.

It is clear how we derived the limit values on the figures below. Three levels of machine condition are defined: **GOOD**, **WARNING** (A long period operation is not acceptable on these machines. They could be working till the time when they could be repaired), and **DANGER** (Vibration values in this range are considered very dangerous and they can cause a damage to the machine). The corresponding colors are taken from the traffic semaphore - green, amber and red.

All limit values are related to the speed value. The low-speed machine should generate lower vibration than a higher-speed machine.

You can find three particular areas in the graphs area. The GOOD condition is the space below the yellow line, which means operation without restriction. The space above yellow but under red line is a WARNING condition. Possible to operate the machine but it has to be checked more. It's necessary to determine the source of the worse condition and plan a repair (for instance changing the bearing) or maintenance (balancing, alignment). The space above red line is a DANGER condition and the machine should not be operated.

First figure contains the values for overall machine condition and you search unbalance, misalignment, and mechanical looseness above all. They are called "overall" because we can measure them on most of the measuring points. Second figure contains the limit values of a roller bearing condition. This condition is local and can be measured only on appropriate bearing house.

Work with figures is simple. It's necessary to know the speed. Instrument determines it automatically or the user can enter it manually. On the bottom horizontal axis, you should find the point which corresponds with speed. Above this point you will find an intersection with yellow and red line. Projections to the vertical axis will determine limit values for yellow or red state. If the measured value is lower than yellow, the condition is GOOD – green. If the value is above yellow but under red then the condition is WARNING – yellow. If the value is higher than red line, then the condition is DANGER – red.

### ***Machine Limits***

The machine limits are used for velocity RMS value in the 10-1000Hz frequency range. This value helps you define the complete health of a machine.

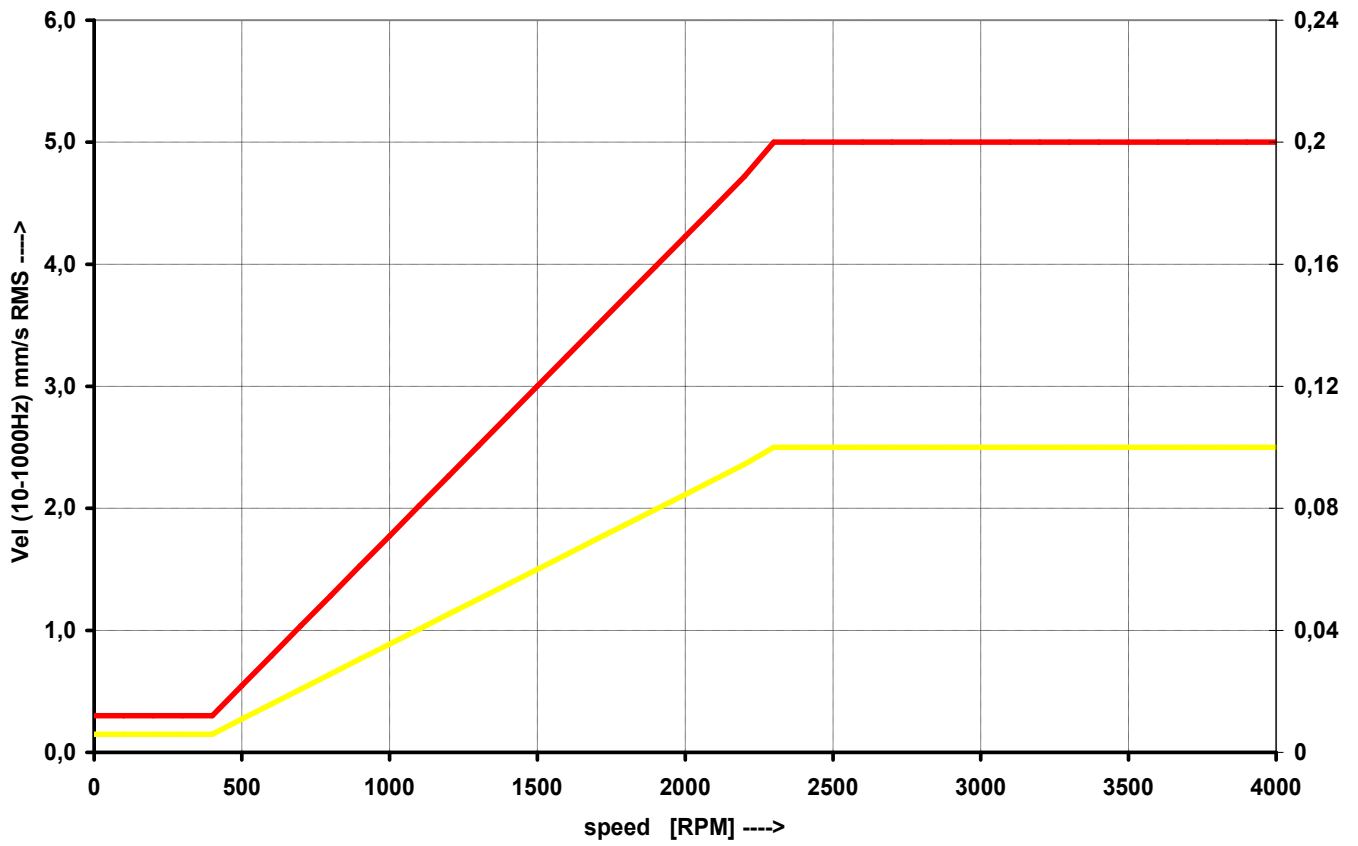

### Bearing Limits

The roller bearing limits are used for acceleration RMS value in the 500-25600Hz frequency range.

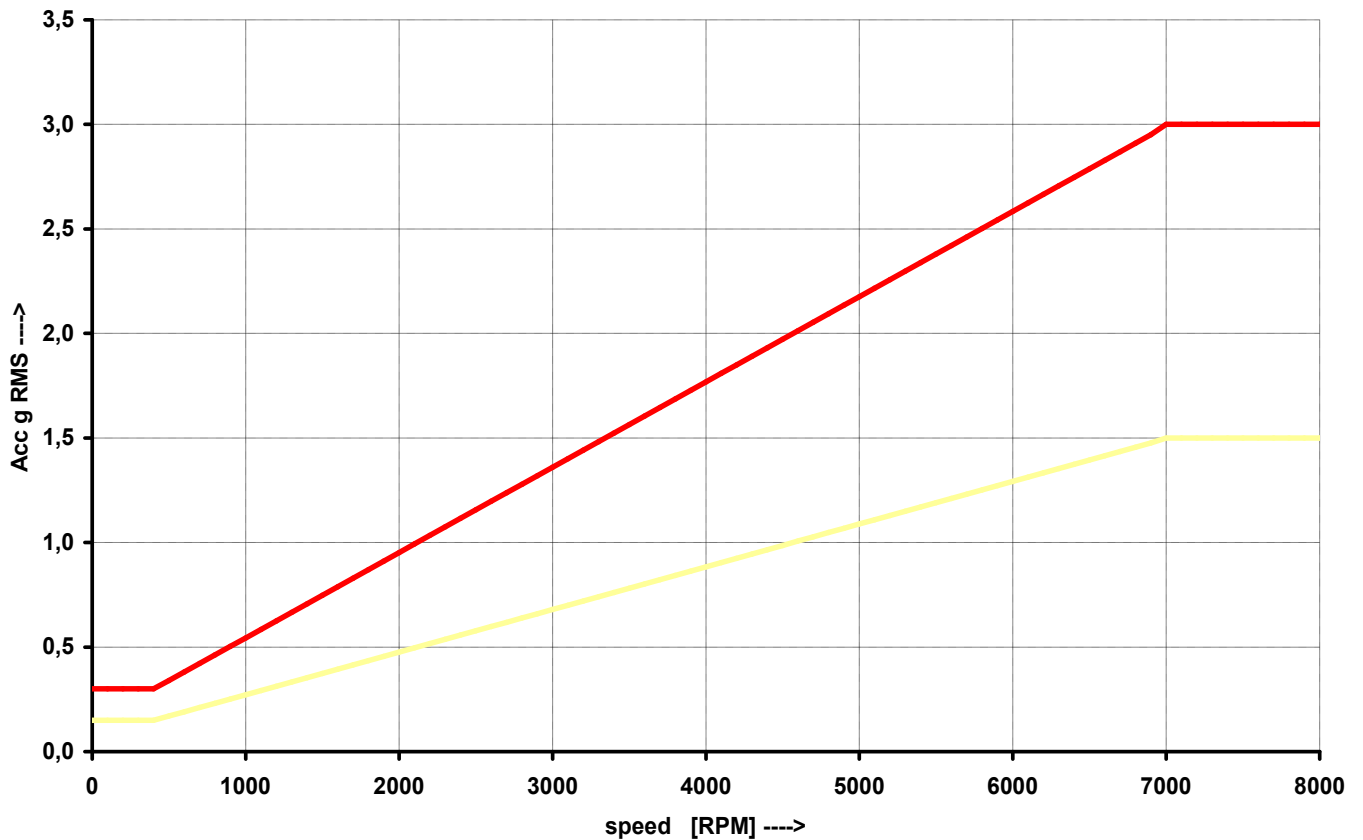

## FASIT Settings

The menu automatically opens after you enter the FASIT module. The menu can be repeatedly opened by the **FASIT Settings** button.

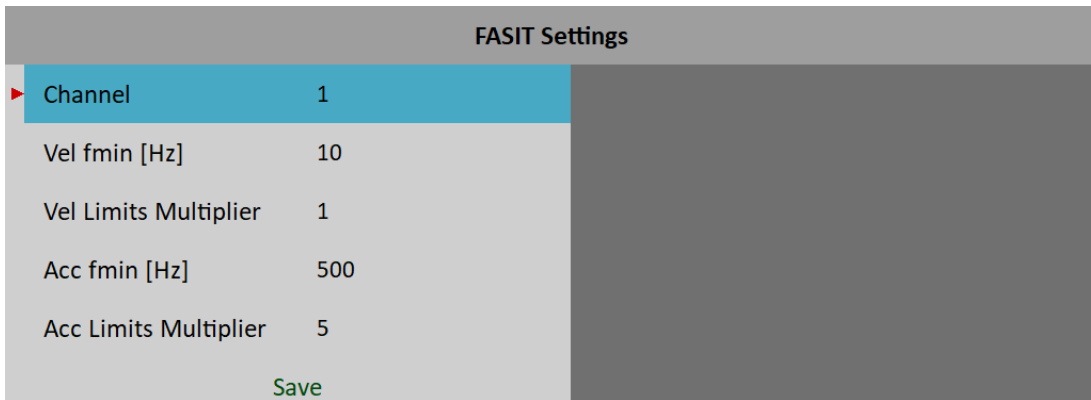

### Channel

The number of the input channel

### Vel fmin [Hz]

By default, the velocity measurement is taken in the 10 – 1000 Hz range to examine the overall machine condition. This range is not convenient for low-speed machines (below 10 Hz = 600 RPM). Therefore, you can setup a lower value of fmin.

### Vel Limits Multiplier

FASIT uses [Adash Vibration Limits](#), according to which alarms are displayed. The factory [Machine Limits](#) may be too strict or too little strict for some machines. Therefore, for velocity measurements, you can adjust them using the *Vel Limits Multiplier*. Values greater than one increase the limit values and values less than one decrease them. A value of one means the limit remains as shown in the machine limits graph. On following figures, you can see the effect of the multiplier. The first machine condition bar shows an alarm when the multiplier is set to 1. The second bar shows the same measurement, however this time the multiplier is set to 2, which means the limit value is twice as high as before. This means that FASIT is less strict and the alarm level is twice lower. The third case shows the situation with the multiplier set to 0.5.

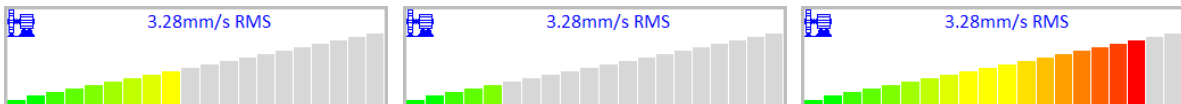

### Acc fmin [Hz]

By default, the acceleration measurement is taken in the 500 – 25600 Hz range to detect bearing faults. Using the Acc fmin you can change the minimum frequency of the filter. E.g., in some cases, there may be vibrations above 500 Hz which are not caused by bearing faults and you know it. Then, you can set the Acc fmin value to 5000 Hz to filter these vibrations out.

### Acc Limits Multiplier

The same as [Vel Limits Multiplier](#) but used for [Bearing Limits](#).

## Sensor Settings

In the [Sensors](#) menu, set the parameters of the used sensor. FASIT measures acceleration and velocity from one channel. If you use a velocity sensor, the bearing condition is not detected. For bearing condition detection, the acceleration measurement is necessary.

Vibration values are displayed in units according to [Global Settings / Units](#).

**metric**

- acceleration – g
- velocity – mm/s

**imperial**

- acceleration – g,
- velocity – ips

**Measurement**

Push the *Enter* button to start the measurement. The speed needs to be known for the processing. The speed detection is described in the [Speed detection](#) chapter.

**FASIT screen**

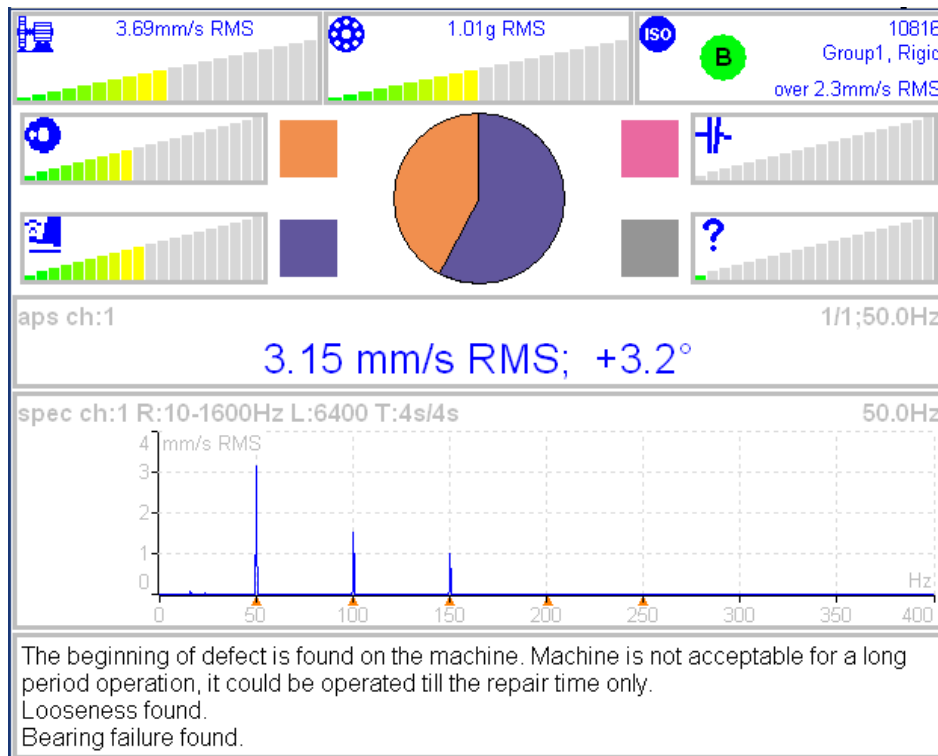

Each horizontal bar displays the severity of an individual item. It starts from green color on the left to the red on the right.

- The machine condition bar, see the Machine limits description above.
- The bearing condition bar, see the Bearings limits description above.
- The Unbalance severity level.
- The Looseness severity level.
- The Misalignment severity level,
- The severity level of a different type of a fault.

 ISO 20816 limits (see the ISO overall measurements), the color of the circle is related to the machine condition class A, B, C, D (the green for A or B, the orange for C and the red for D). Also, the information about machine group and foundation are displayed. The limit which is exceeded is also displayed at the bottom.

The pie chart displays the percentages of severity of individual faults. The colors in the pie chart correspond to the colors of the rectangle next to the individual graphs.

The 1x amp+phase value and velocity spectrum with speed and harmonics (marked by red triangles) are displayed in the middle of the screen.

**Note!** the 1x amp+phase value is displayed only when the speed is measured by a tacho probe.

The condition report and advices are in the bottom.

# Stethoscope

This module enables you to listen to vibrations. Use the standard headphones and connect them to the audio output on the top panel. Enter the Stethoscope module. Four displays appear. Push *Enter*. Each input signal level will be displayed.



The **TRUE PEAK** level is displayed. You choose the channel for listening by the buttons on the left side. The selected channel is written in the status bar. The **Volume** button changes the buttons mode to volume regulation.

## The delay of audio output

Because all signal conditioning is digitally arranged, the delay of signal appears. The delay is usually 1 second. You can test it by knocking to the sensor. You will hear this knock after the delay time.

## Playback Settings

Push the **Playback Settings** button for playback settings.

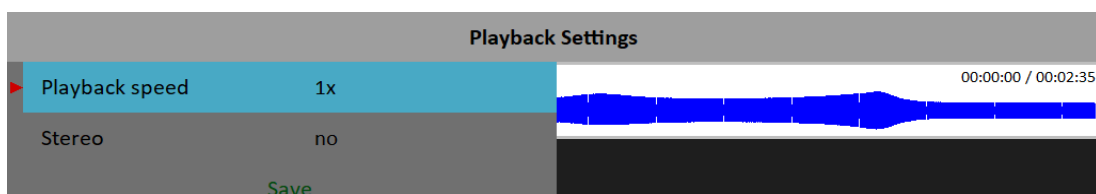

## Playback speed

This function is available only when a record is listened to. It speeds up (larger than 1) or slows down (lesser than 1) the playback speed.

### Stereo

**yes, no**

It enables you to define two channels for playback, one channel for the left headphone and the second for the right one. The current setting of left/right output is displayed on the status line on the left top (**L: AC 1, R: AC 2**). The **Left** note in the bottom left corner says that you setup the left channel at this moment. Push the **AC1 – AC4** to change the number of the left channel. Push the **Left/Right** button and the **Left** note changes to **Right**. Then the **AC1 – AC4** buttons enable you to setup the number of the right channel.





## **Lubri - the greasing control**

There is an increasing demand for an instrument which is able to easily check the lubrication of rolling bearings and also the condition of these bearings.

For every machine, it is specified how much lubricant every one of its bearings uses in a specific number of operational hours. A task of each technician or engineer is to regularly check all the lubricated points and maintain the sufficient levels of a lubricant. Either state, lack or excess of a lubricant are harmful for a rolling bearing element. The result is always an excessive stress on the bearing and consequently excessive wear. Every lubricating point has a lubrication time interval (in hours of service) and also an amount of lubricant that needs to be replenished. This manner of lubrication control has a significant disadvantage.

The amount of lubricant that any bearing actually needs for proper operation changes during its lifetime. Longer lubricating intervals in case of a new machine are usually not sufficient for a machine after several years of operation.

It is clear that it would be useful for technicians to be able to determine a state of a bearing somehow and replenish only as much lubricant as is actually needed. Controlled lubrication increases the bearing service life and lowers the costs for lubrication and repairs.

The main use of this Lubri module is in the lubrication replenishment process. During this process, the instrument measures the current lubrication condition of a bearing and tells the operator when the amount of lubricant is ideal. This way, it is ensured that we do not under lubricate or over lubricate. This module exactly determines the ideal amount of lubricant needed.

As a result, your machines will be maintained in their best lubrication condition. The Lubri module enables you to make the whole lubricating process simpler and it normally reduces the consumption of very expensive lubricants.

You can find more detailed information about lubrication in the A4910 – Lubri manual.

### ***Two Ways How to Mount a Sensor***

A standard accelerometer mounted on a bearing housing is used to measure lubrication.

You have two possibilities of doing this:

1. ***The sensor is mounted on a lubrication head.***  
This option enables a quick service since the lubrication head is transferred together with the sensor. The disadvantage is a partial loss of sensitivity, since the lubrication head attenuates the measured signal.
2. ***The sensor is mounted next to a lubrication point on a bearing housing (measurement pad recommended).***  
This option enables a perfect measurement. The disadvantage is a longer preparation, since the lubrication head and sensor must be mounted separately.

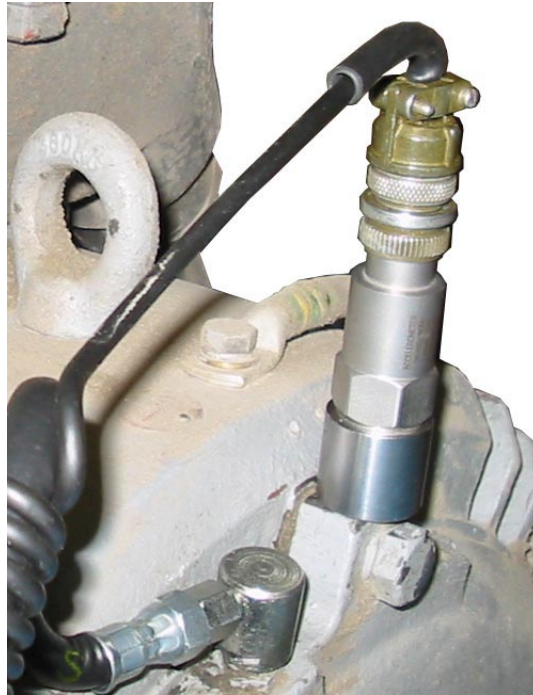

Sensor mounted close to a lubrication point

If vibration diagnostic measurements are performed on a machine, then a measurement pad is already mounted. This pad can also be used for lubrication measurements.

**Procedure**

Mount the sensor near the bearing. Prepare the greasing gun for use.

Open the Lubri module and select the input channel which will be used for measurement. Push the *Enter* button to start the measurement. Then, the instrument will measure the current lubrication state.

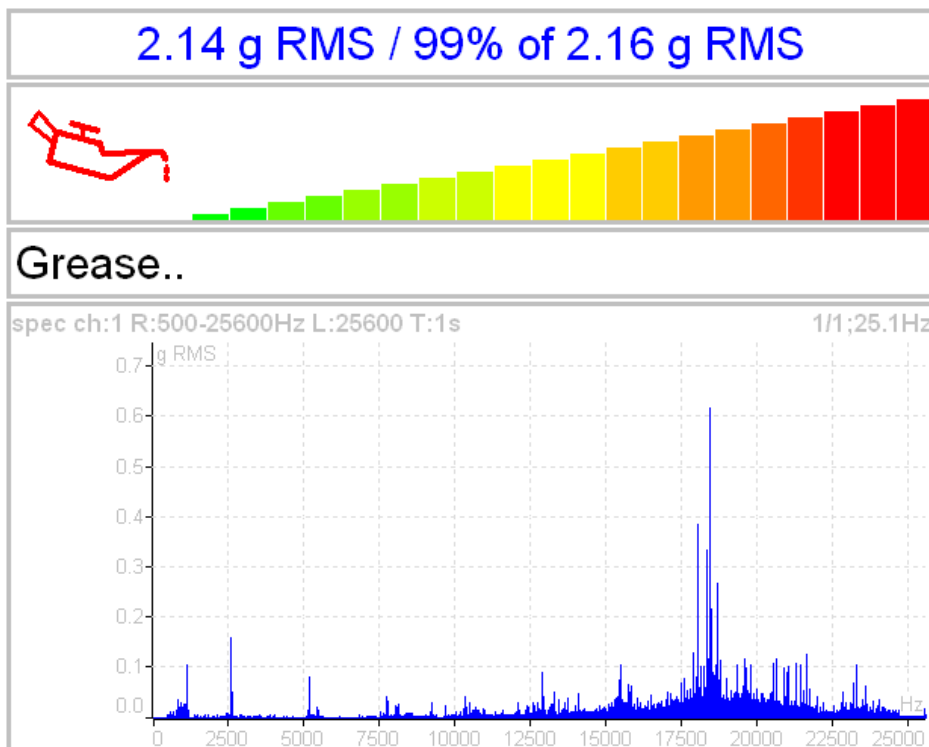

The instrument continually takes a g RMS value in the frequency band 500 - 25600 Hz and compares it to the initial value. The first line contains the current g RMS value and the proportion to initial value in %.

Below the first line is a horizontal bar, which indicates the current lubrication state. Its level always reaches a maximum after the procedure start.

The recommendations are also displayed below the bar. The acceleration spectrum is displayed in the bottom. You can look at the spectrum changes during the procedure.

You need to slowly start adding lubricant while monitoring the height of the column on the display. There is usually not much going on in the beginning, which means that the lubricant is pushed towards the bearing, however it is not there yet. At the moment when the lubricant reaches the bearing, the column decreases (usually its red part disappears and only the green part remains). You need to add a little more lubricant, and if there is no further decrease, you end the lubrication process.

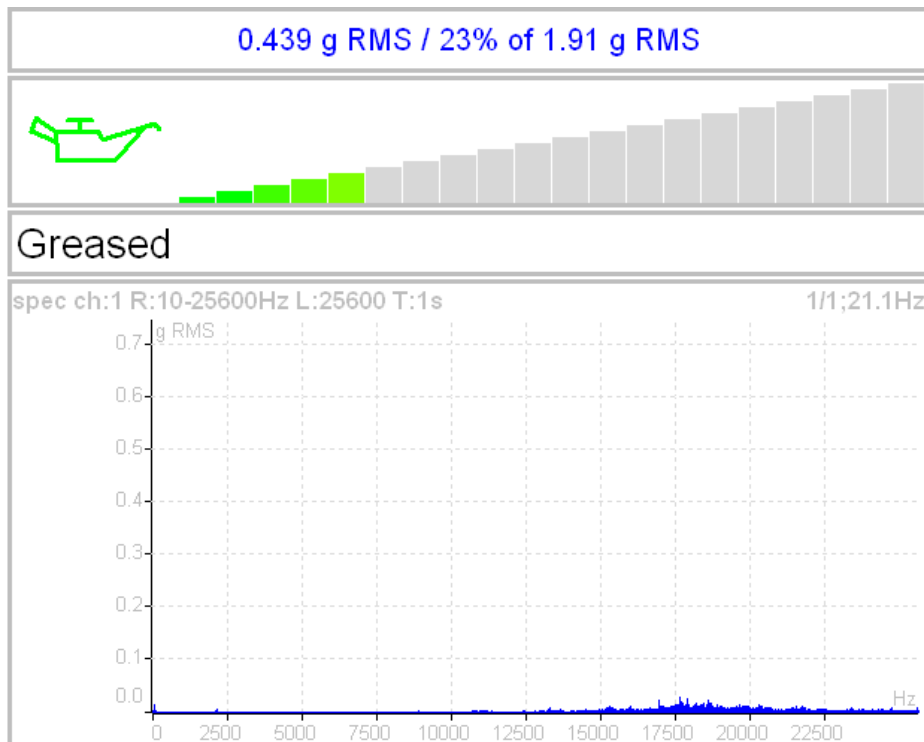

**Note!** If, at the beginning of measurement, the value of vibrations is low and oilcan is green, then we have either a new or a very well-greased bearing.

## Octave Analysis

The Octave Analysis module is designed for sound measurements. It works the same as the [Analyzer](#) module. It enables exponential averaging.

### Measurement Settings

| Edit Measurement    |                                       |
|---------------------|---------------------------------------|
| Type                | octave spectrum<br>freerun, retrigger |
| All Channels        | no                                    |
| Channel             | 1                                     |
| Unit                | Pa                                    |
| Resolution          | 1/1                                   |
| Frequency Range[Hz] | 16-16000                              |
| Frequency Weighting | none                                  |
| Averaging           | linear                                |
| Avg                 | off<br>total t = 0.125 s              |
| <b>Save</b>         |                                       |

#### **Type**

##### **octave spectrum**

##### **sound level**

The sound pressure level in dB is defined as  $20\log_{10}(p_{RMS}/p_0)$ ,  $p_0=0,00002$  Pa ( $p$  is sound pressure)

##### **equivalent sound level**

When the sound level changes during a time interval, then the equivalent sound level is the average sound level of the whole interval.

#### **Channel**

1 - 4

#### **Unit**

The unit of measurement (has to be compatible with sensor settings)

#### **Resolution**

1/1, 1/3, 1/12, 1/24

#### **Frequency Range**

1-63 Hz, ..., 16-16000 Hz

The central frequencies of the lowest and highest octave.

## Frequency Weighting

### none, A, B, C, D

The human ear has the subjective characteristic known as loudness. It is the function of sound intensity and frequency. For example, the 20Hz pure tone with sound level 20dB would be clearly audible. The 100Hz with the same level would not be heard, it lies below the threshold of hearing. The unit of loudness is **phon**. The loudness level in phons of any sound is defined as being numerically equal to the intensity level in dB of a 1000Hz tone. The purpose of weighting is to make the readings correspond to the loudness level as closely as possible. Historically, four weighting were defined:

- A used for loudness levels below 55 phons.
- B used for loudness levels between 55 and 85 phons.
- C used for loudness levels over 85 phons.
- D used especially for aircraft noise.

However, A-weighting is frequently specified today for measurements irrespective of level.

## Averaging

### linear

The standard arithmetic mean for every line

### peak hold

The maximum value during the measurement for every line

### exponential

The continuous measurement where the older spectra have less weighting than the newer

## Avg

**off** or the number of values in an average

## Measurement

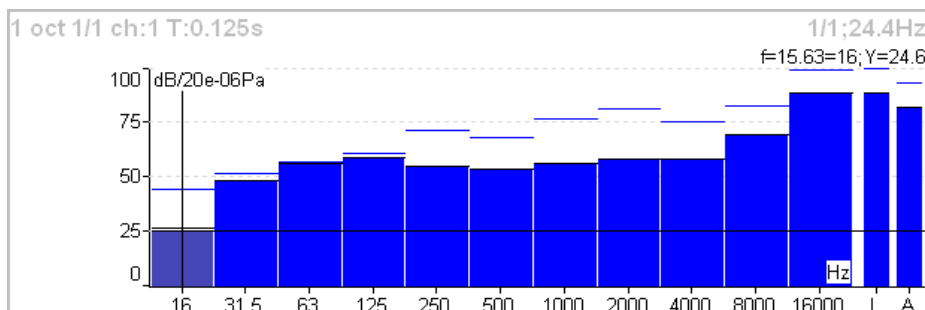

Each spectrum is combined with two bars at the right side. The total sound level **L** and the used weighting level **A – D** are displayed. The line over each line is the maximum peak reached during the measurement.

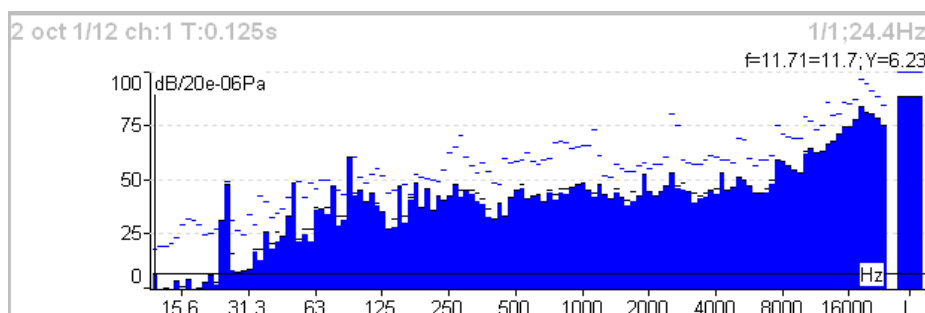

## Octave Analysis Algorithm

Octave analysis uses a set of digital filters. Each filter has a designated center frequency and bandwidth. Filters are designed according to ANSI S1.11:2004 and IEC1260:1995.

## **Bump Test**

It enables you to find the resonance frequency of the machine's body.

The test contains two parts. The level of amplitude trigger is found in the first part. The response spectrum is developed in the second part.

### **Settings**

The *Settings* menu opens after you enter the Bump Test module. You can open it later using the **New Test** button.

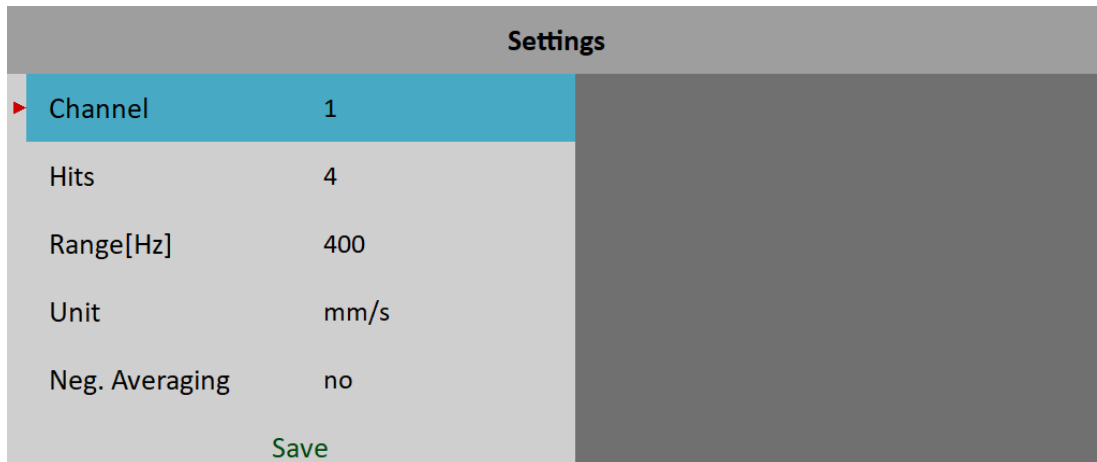

#### **Channel**

Input channel number

#### **Hits**

Number of hits. It's the same as the number of signals for averaging in spectrum.

#### **Range**

Frequency range (maximum frequency) of the analysis.

#### **Unit**

Measurement unit. Integration of a signal is also possible.

#### **Negative Averaging**

See [MENU / SETTINGS / Trigger Settings / Negative Averaging](#)

### **Amplitude Trigger**

In the first part of the test, we need to detect the correct value for triggering. The system sets it automatically. Start the test by the *Enter* button. Make the hit and look at the movement of the hand on the display. Make all hits with approximately the same force. More than one hit is recommended (3-4). Push *Escape* to finish the first part. The second part begins automatically.

**Attention!** Make all hits with approximately the same force throughout the whole test.



### ***Response Spectrum***

Continue with hits in part 2. The spectrum with resonance frequencies is displayed after the first hit and the averaging is used for the next hits. Look at the top right corner and make the hit when the message “*Waiting for trigger*” is displayed. The test is stopped after reaching the specified number of hits. You can also stop it by the *Escape* button anytime.

**Note!** You don't need to wait for the “*Waiting for trigger*” message. The hit can be performed immediately after the spectrum on the screen is updated.

**Note!** A 10 Hz high pass filter is used during signal processing. Frequencies below this value are removed.

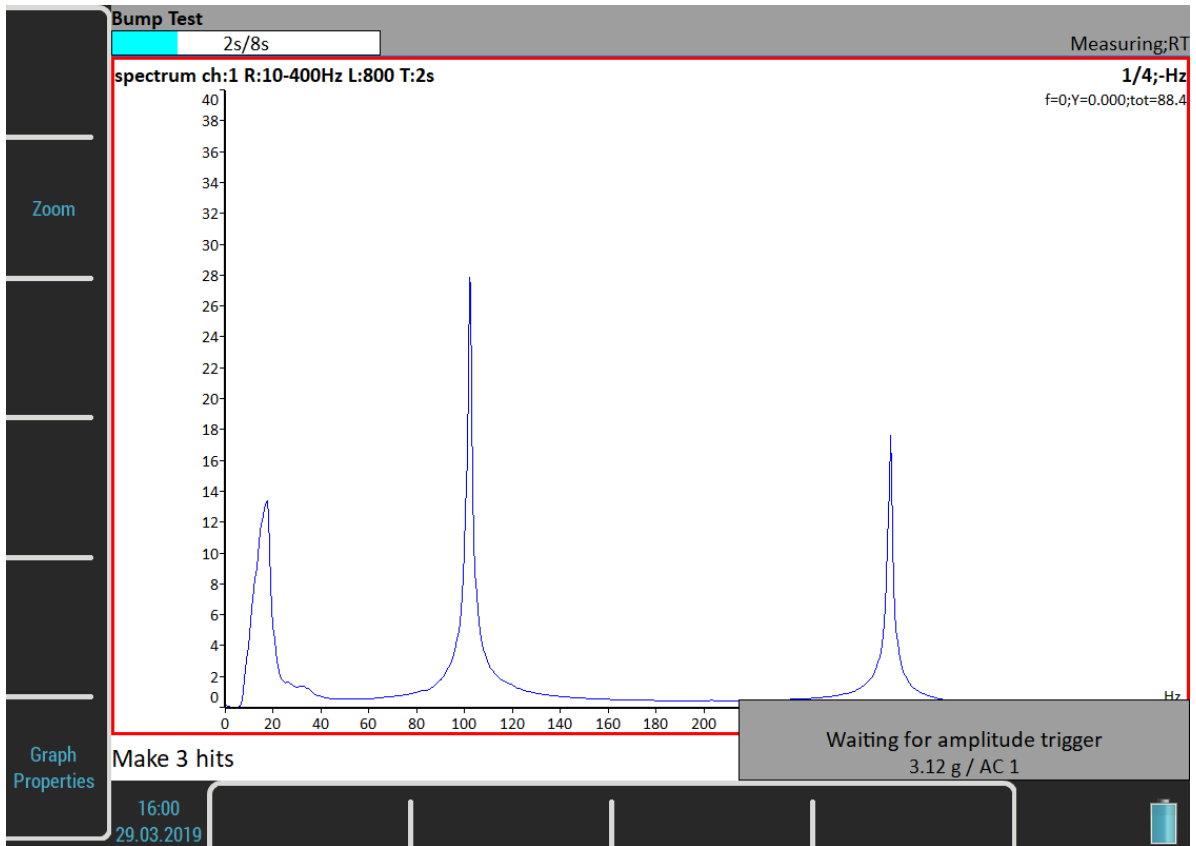

### Analysis

The spectrum graph has the same properties like in the Analyzer mode. Using of the [Graph Properties/ Peaks List](#) helps you detect required frequencies.

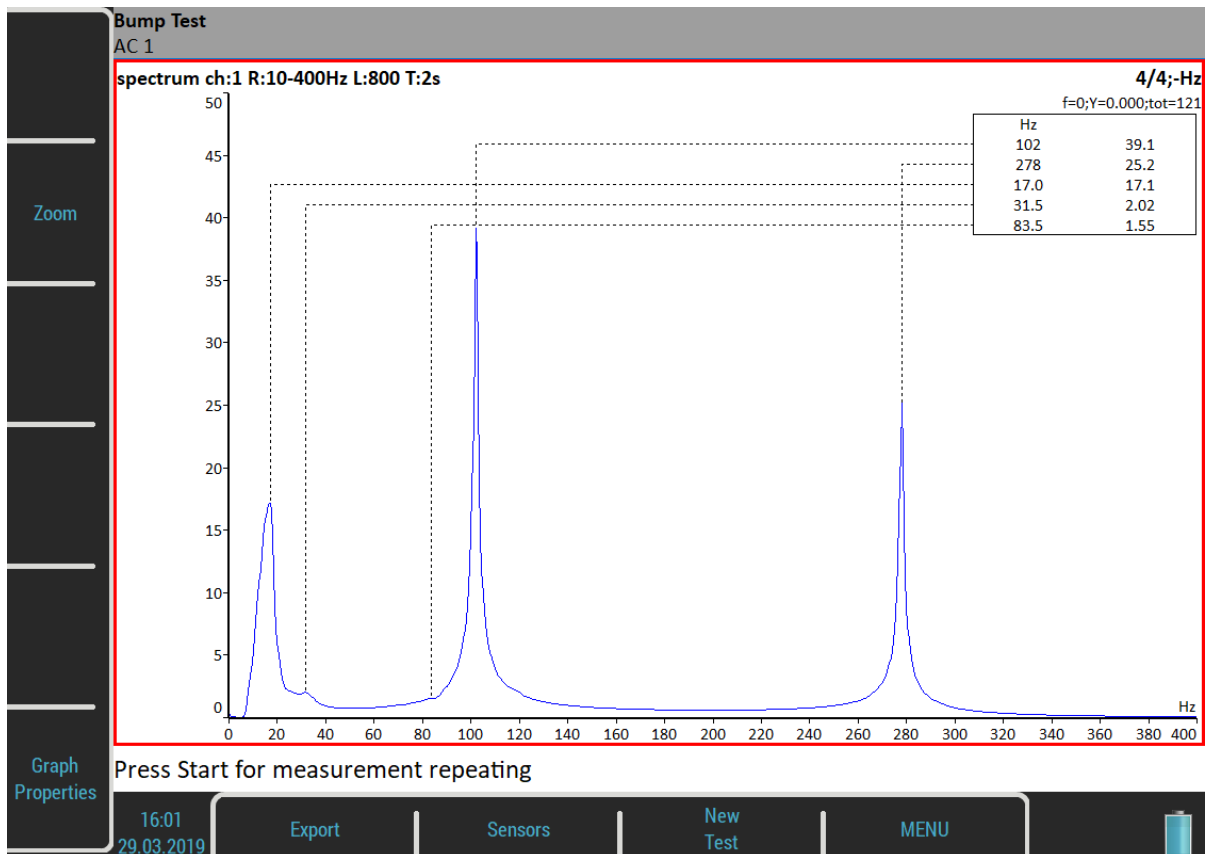



**Buttons*****Enter***

Repeats the second part with the same trigger level.

***New test***

Starts a new test including the trigger level initialization.

***Export***

Exports spectrum from **bump<sub>test</sub>** to Analyzer or to the *VA5\_DISC* as an Analyzer project. This project can be imported to DDS.

## **ADS**

The ADS (Adash Deflection Shapes) module enables you to measure operating deflection shapes of the machine.

### ***ADS project***

The project must be created on the computer. The ADS software enables you to create the geometry of the machine (points, lines and directions).

#### ***Project Import to VA5***

On PC, copy the project file (ads extension) to the *VA5\_DISC* either to the root or to the *VA4ads* folder. The project will be moved to the instrument memory after entering the ADS module. The file on the *VA5\_DISC* will be deleted.

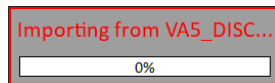

#### ***Rewriting of geometry***

The user usually creates the simple geometry first and takes the measurements. After that first test, he changes the geometry (adds next points, lines, and directions). When the project is imported to the instrument again, then only the geometry file will be rewritten. The already taken data will not be deleted.

### ***Project List***

The project list opens after entering the module.

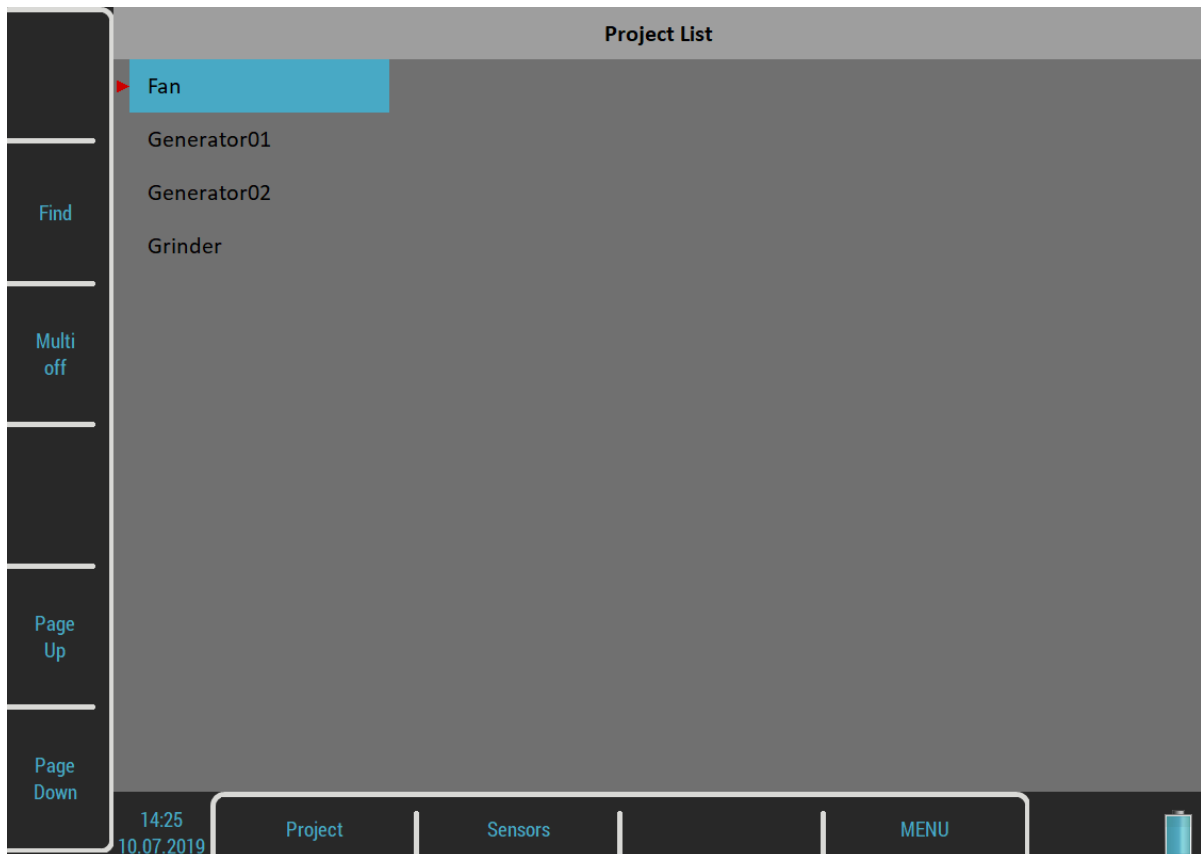

## **Project Menu**

Push the **Project** button to open the menu. The **Create** item is missing here. You can create an ADS project only by importing geometry from computer (see above).

### **Copy**

Copies the selected project to a new project without measured data.

### **Rename**

Renames the selected project.

### **Delete**

Deletes the selected project(s).

### **Clear Data**

Deletes all readings in the selected project(s).

### **Export Data**

Exports readings to the *VA5\_DISC*. File with "**name**".*dsd* will be saved to the *VA4ads* folder. It is prepared for import in the ADS application.

### **Export Project**

Exports the whole project, both readings and geometry, to the *VA5\_DISC*. This project can then be used in Virtual Unit application.

## **ADS Settings**

Select the required project in the project list and open it. The settings of measurement parameters are required when the project is opened the first time. You can change the settings any time later using the **ADS Settings** button.

**ADS Settings**

|                              |                           |  |
|------------------------------|---------------------------|--|
| <b>Type</b>                  | frf<br>freerun, single    |  |
| Input                        | 1                         |  |
| Window                       | hanning                   |  |
| Output                       | 2                         |  |
| Window                       | hanning                   |  |
| Result Type                  | H1                        |  |
| Range[Hz]                    | 800<br>fs = 2048 Hz       |  |
| Lines                        | 800<br>t = 1 s, df = 1 Hz |  |
| Avg                          | 4<br>total t = 4 s        |  |
| Overlap                      | 0%                        |  |
| Reference Direction          | 1                         |  |
| Frequency for Animation [Hz] | 50                        |  |
| Vibration Scale              | 0.5                       |  |
| Save                         |                           |  |

### Measurement Definition

The [amp+phase](#), [Orders](#), or [Frf](#) are available measurement types for ADS. All parameters are the same as in [Analyzer](#) / [Edit Measurement](#).

**Attention!** The change of the measurement parameters requires deleting all saved readings when they are not compatible with the new definition. The only parameter you can change without losing readings is the channel number.

### Reference Direction

This parameter is available only for **frf** measurement type. One reference sensor is mounted to one point (one direction) on the machine and is in that place all the time. The second sensor is moved sequentially to all other directions.

**Attention!** The change of the *Reference Direction* number requires deleting all saved readings, because they are not compatible with new reference direction number.

### Frequency for Animation

Specifies which frequency of frf will be used for animation on the VA5 screen. This setup is available only for frf measurement. In case of amp+phase or orders, the speed frequency (1X) will be used for animation.

### Vibration Scale

<0, 1>

Scales amplitudes of vibrations in animation.

### Views

Three types of screen view are available. Use the **View** button to switch it.

### Machine View

The geometry is displayed. Directions contain numbers. The reference direction is marked as **R**. Just the selected point contains a small circle. Just the selected direction is drawn by a different color.

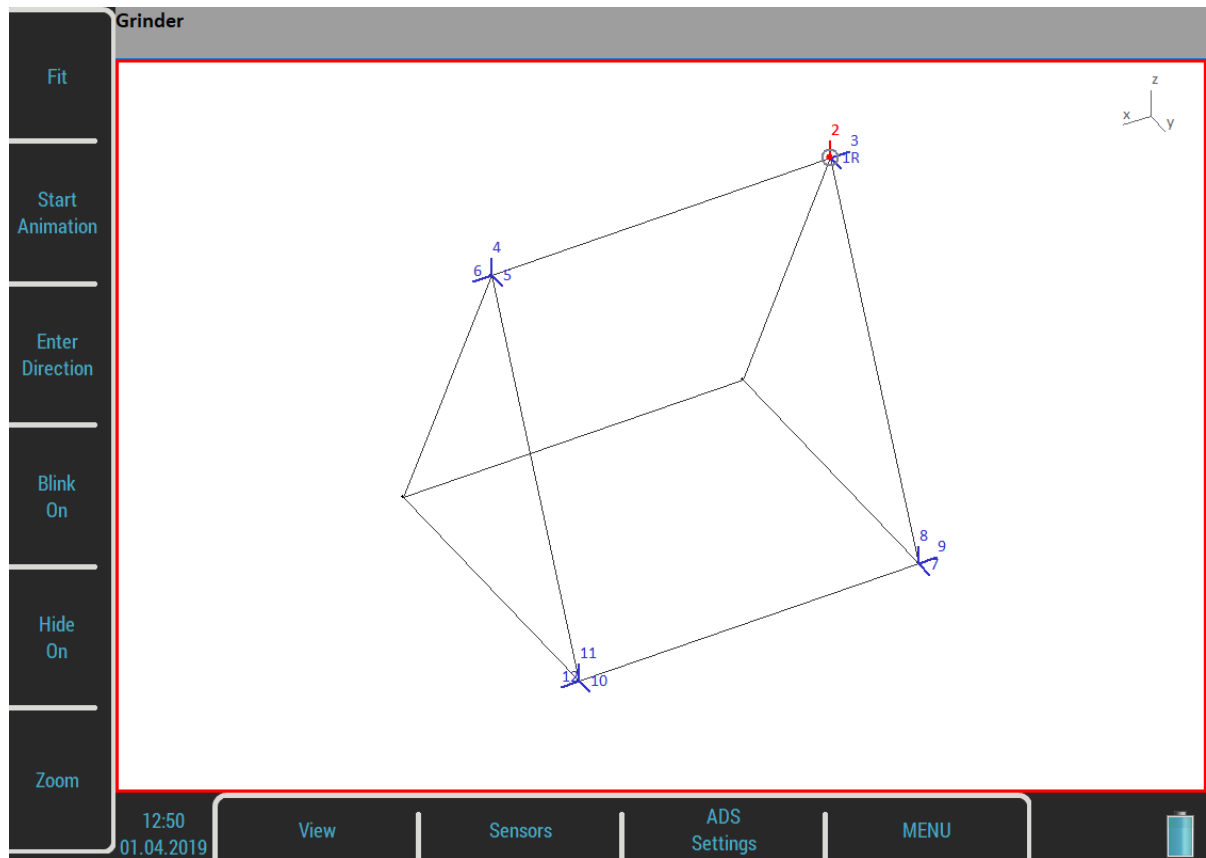

### Measurement View

The standard graph with measurement is displayed. The number of the selected direction is displayed in front of the measurement type (**2 frf ....**)



### Machine+Measurement View

Both previous screens are displayed together. The user can select one of them to be focused (the red border) with the **View** button and to work with it.

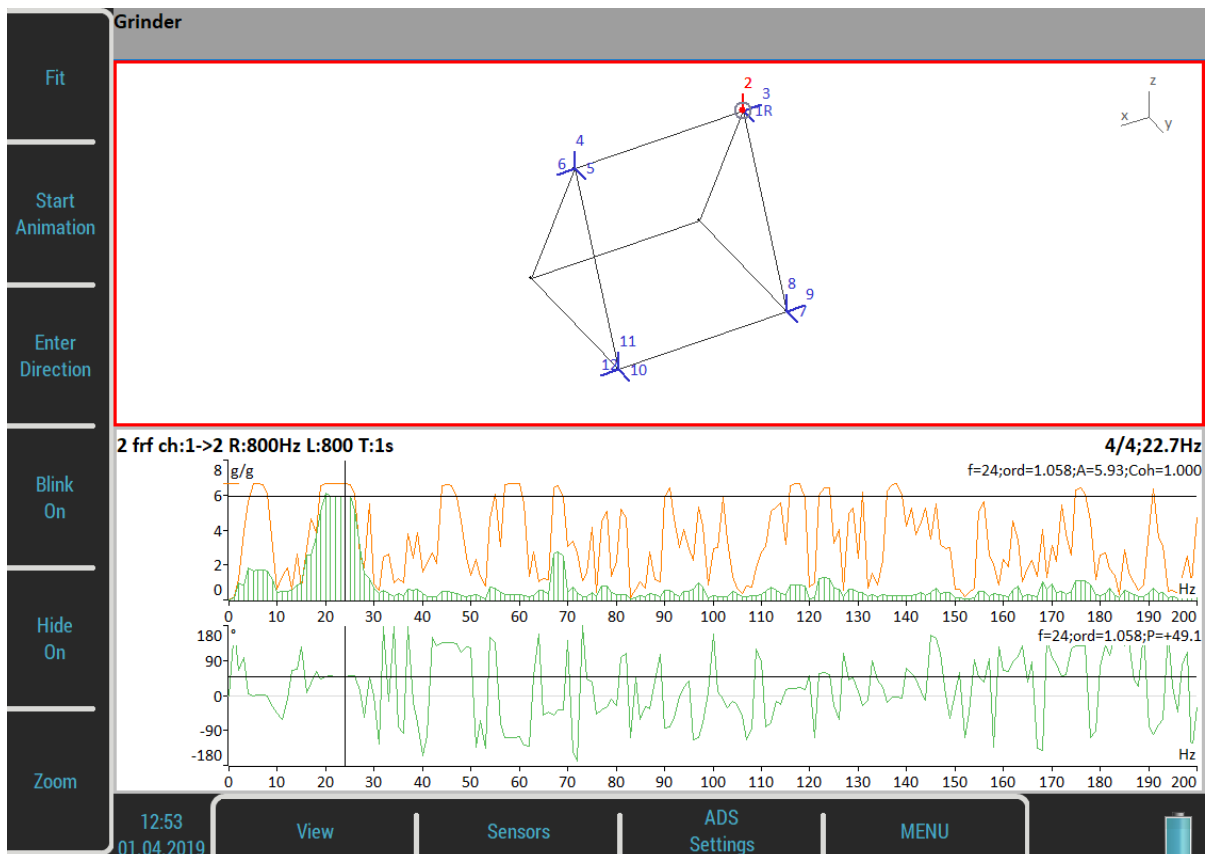

### ***Automatic change of view***

When the measurement starts, the machine view is replaced by the measurement view.

## ***Buttons for Machine View***

### ***Fit***

Auto-zoom of the machine in window

### ***Start/Stop Animation***

Runs or stops the animation.

### ***Enter Direction***

Opens a dialog to manually enter the direction number.

### ***Blink on/Blink off***

The directions, which have not been measured yet, can blink.

### ***Hide on/Hide off***

The directions, which have been measured yet, can be hidden.

### ***Zoom***

Switches buttons to the ***Zoom / Move / Rotate***. Push the *Tab* or the *Backspace* button to return the initial mode. Zoom and move functions are also available using the touch screen.

### ***Left / Right Arrow - Direction***

Changes the direction number on the selected point. The new direction can also be entered by the [Enter Direction](#) button.

### ***Up / Down Arrow - Point***

Moves the point selection (blinking circle). When the new selection is confirmed by ***Enter***, then the selected direction is also moved to that point.

### ***Enter***

Starts a new measurement on the active direction.

## ***Buttons for Measurement View***

### ***Zoom***

Switches buttons to ***Zoom***. Push the *Tab* or the *Backspace* button to return to the initial mode.

### ***Graph Properties***

Open the ***Graph Properties*** dialog which is described in the ***Analyzer*** module.

**180° on/180°off**

Sometimes, it is not possible to mount the sensor to a direction which is defined in geometry. In such case, it is usually possible to mount the sensor in the opposite direction. Use this button then and change the phase about 180 degrees.

**Save**

Saves the reading.

The saved readings are displayed in a graph while selecting directions in a model. Directions already measured are color coded in the model. When you select a measured direction, its signal is displayed in the graph. Direction number, amplitude, phase, and frequency of animation are displayed in the status bar for the selected direction.

**Grinder**

2: A = 5.69 g 0-P, P = +45.0°, f = 50 Hz



## Ultrasound

We would like to explain a few terms at the beginning of this chapter.

Higher frequency energy above 20 kHz is best detected with an ultrasonic sensor. Most useful information is found between 30 and 50 kHz. The ultrasonic module enables the monitoring of ultrasonic energy.

Ultrasound utilizes a solid, liquid or a gas to transmit (will not exist in a vacuum), and it is a very directional and short waveform. It has several things in common with vibration, for instance, the ability to detect ultrasound energy requires the sensor to be focused in the direction of the waveforms.

Field applications for airborne ultrasound detection:

- Consider that the wave energy is easily reflected and attenuated.
- When looking to detect airborne ultrasound energy, a rule of half distance twice amplitude is a good thing to consider, this is called the "inverse rule".
- Remember airborne ultrasound is easily reflected, when detecting a leak, you should turn in the other direction to determine if the sound is coming from behind you.
- Use shields such as cardboard or isolate the potential defect from other sources.

For airborne ultrasound, the instrument microphone attachment will detect:

- Air leaks
- Vacuum leaks
- Electrical Arcing
- Electrical Corona
- Tightness testing where a signal generator is located within a sealed unit. By scanning the sealed areas from the outside, leaks can be detected.

A probe attachment that enables a direct transmission of ultrasound will detect:

- Early signs of poor lubrication in anti-friction roller bearings
- Impacting noise from defects in roller bearings including bearings with shaft speeds under 100 rpm.
- Steam trap leakage and failures
- Gearbox defects
- Valve leakage
- Actuator malfunctions

### **Sensor Setting**

Ultrasound measurement is available only on AC1 which has the specific powering for the ultrasound microphone (see [Input Channels](#) / [IN1 Socket](#)). When you enter the module, the sensor is automatically changed to Pascal sensor.

Used Sensor  
on AC1: 200 mV / Pa, ICP off

Use the [Sensors](#) / [AC1](#) to change the sensitivity if needed. The new setting is saved and used in the next run.

**Note!** The original sensor is set when you leave the module.

### **Settings**

You can set the scale of the displayed bar graph. Open the menu by the **Ultrasound Settings** button.

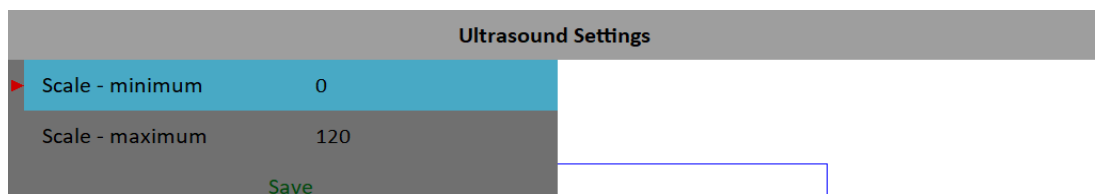

**Scale – minimum**

The minimum value on the bar graph.

**Scale – maximum**

The maximum value on the bar graph.

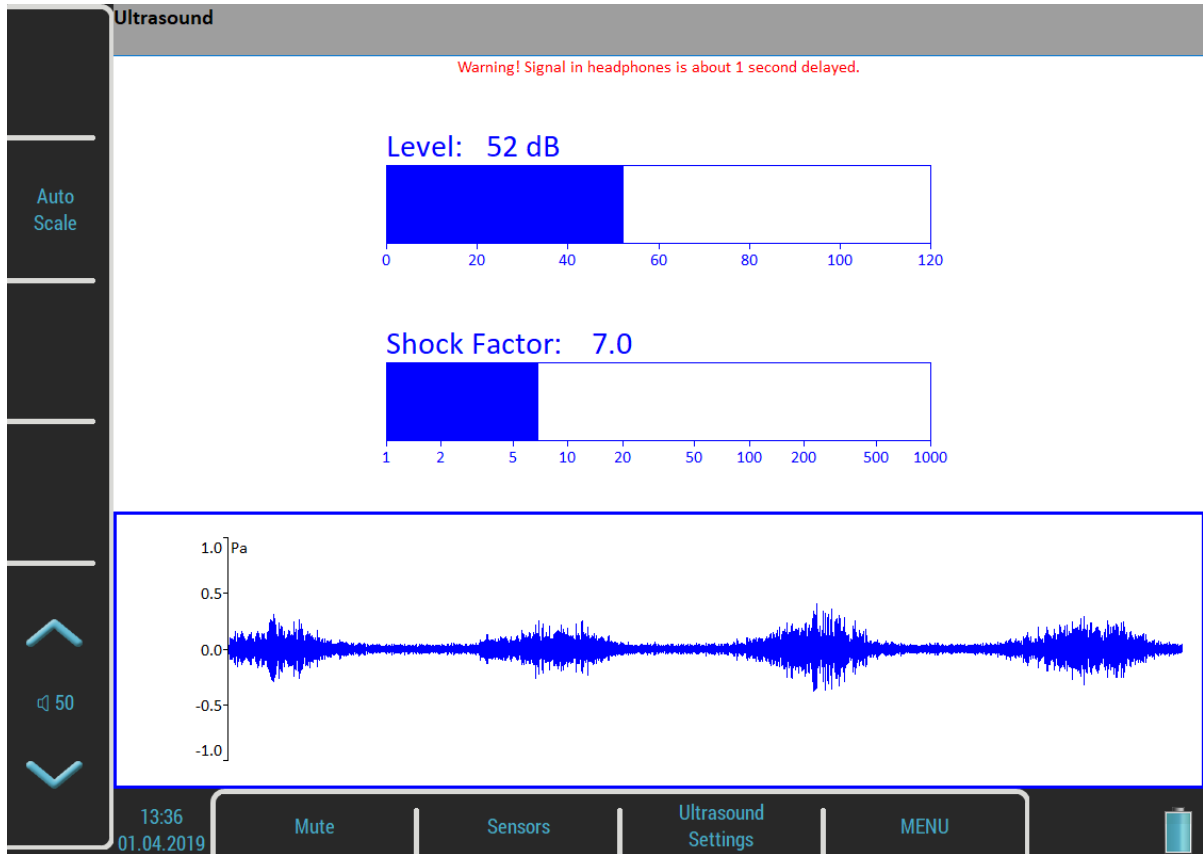
**Measurement**

Push the *Enter* button. Two values are displayed, the **Level** of sound in dB and **Shock Factor**. The **Shock Factor** is defined as Peak value divided by RMS value. It means the value 1.4 for pure sine. Higher value means that transient shock events are in the sound signal.

The time waveform is displayed at the bottom of the screen. Use the **Auto Scale** button to fit the scale of the graph.

The ultrasound is demodulated to the frequencies around 1kHz and you can hear it in headphones. Use the volume buttons to set the correct level.

Push *Escape* to stop the reading.

**Attention!** The signal in headphones is about 1 second delayed. It is because of digital processing, which takes this time.

## **Camera**

The VA5 instrument is equipped with an optical camera. The picture from the camera is automatically on the screen a few seconds after opening the module.

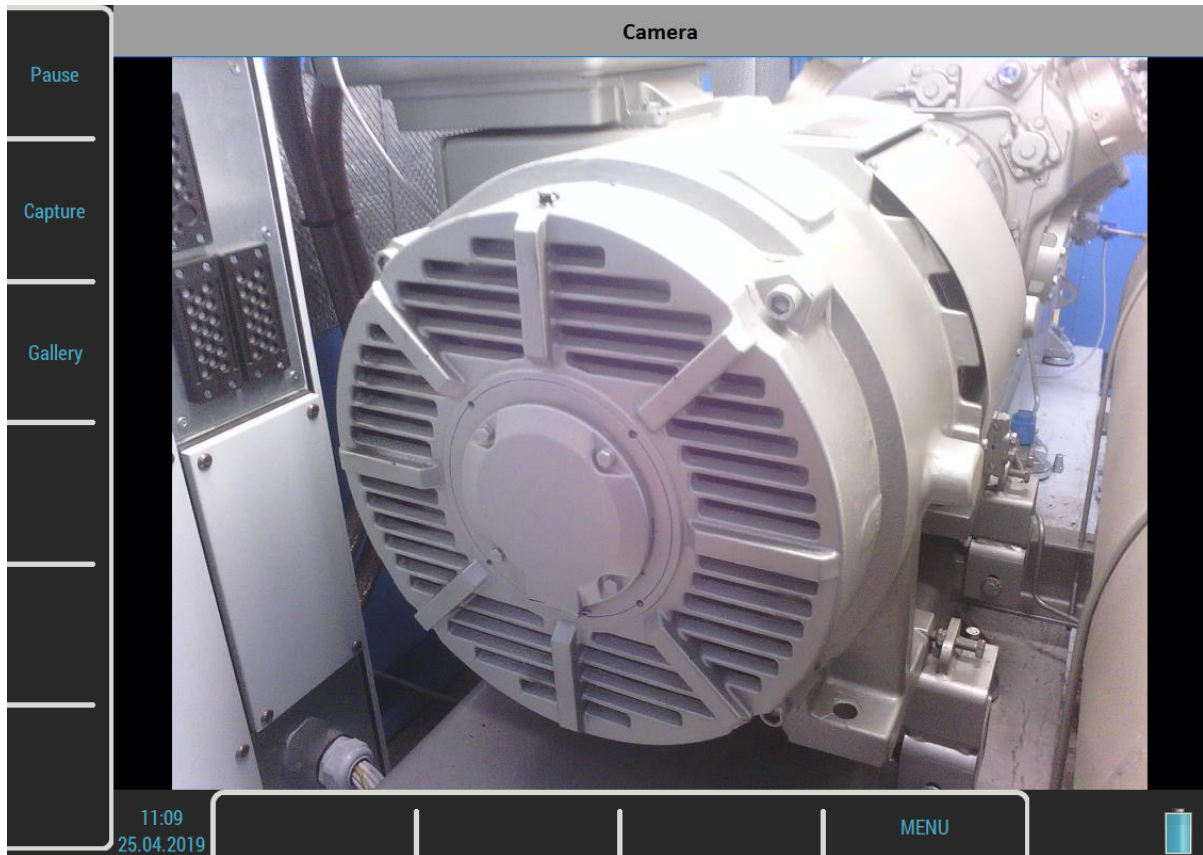

## **Buttons**

### ***Pause / Run***

Freezes a picture from the camera and then runs it again.

### ***Capture***

Takes a picture. All images are saved to the **images** folder on the **VA5\_DISC**.

### ***Gallery***

Open a [Gallery](#) so you can watch taken pictures.

## **IR Camera**

The IR camera can be connected to the micro USB slot on the instrument's top panel. The IR camera is not a part of the standard VA5 instrument set. You can order it at your vendor.

### **Operation**

- 1/ Plug the supported IR camera into the micro USB slot.
- 2/ Run the **IR Camera** module.
- 3/ Wait a few seconds until the camera initializes.

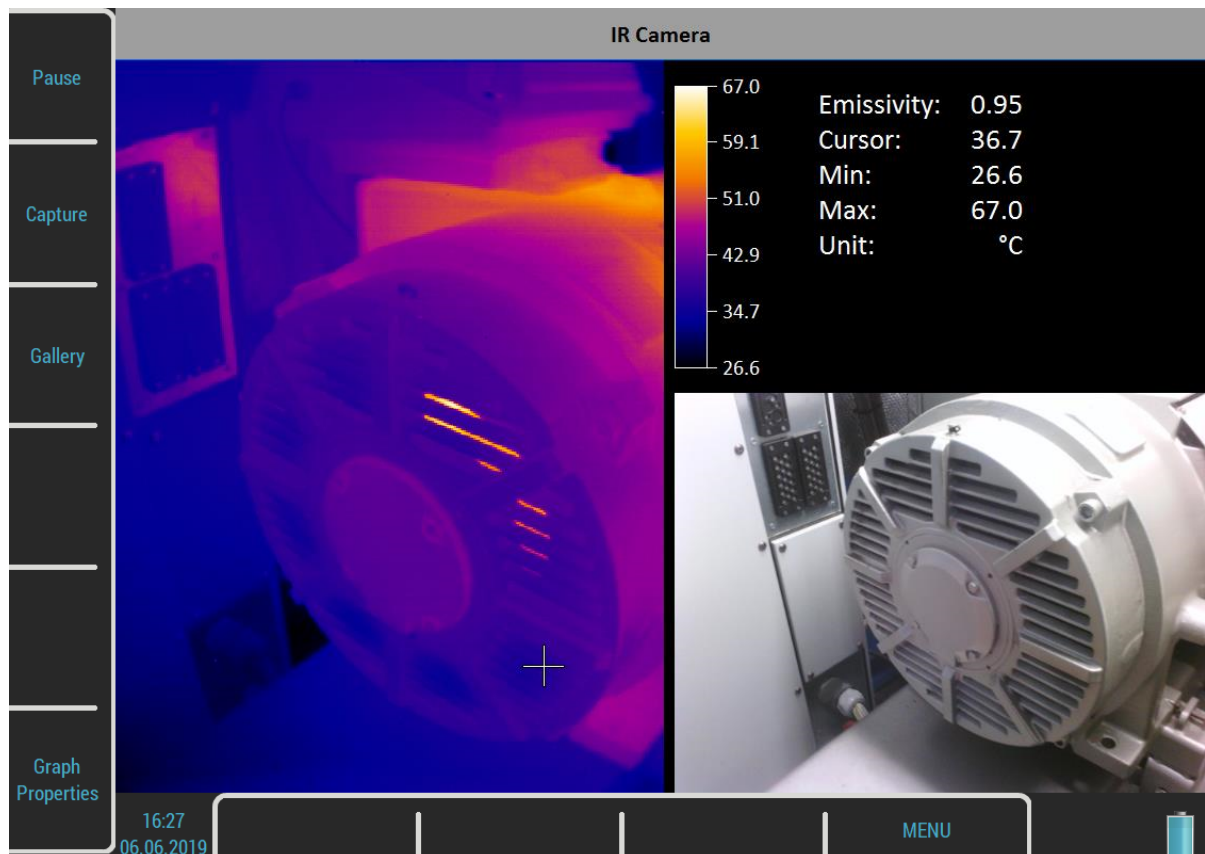

The image from the IR camera is in the left half of the screen. The image of nearly the same scene from the optical camera is in the bottom right corner. The information panel is in the top right corner. You can see the minimum and maximum temperature and the temperature of the point under the cursor. Use arrows or tap the touch screen to change the cursor position.

### **Focus**

The supported IR camera uses manual focus. You may adjust the focus (refocus) by turning the lens to sharpen the focus for the distance of the target.

### **Warming Up**

The IR camera needs some time to warm up after connection. During warm-up, you may notice a slow decrease of temperature. It is in units of percent. This typically takes about five minutes.

### **Cursor**

Use arrow buttons or tap the IR image to move the cursor cross. The temperature of the point under the cursor is written in the table.

### **Pause / Run**

Pauses and then runs the scene again.

### **Capture**

Takes the image of the scene. Two files will be stored in the **images** folder on the **VA5\_DISC**. One file stores the raw temperatures from the IR camera in the special thm format. You can work with this file in the DDS software. The second file is the png picture of the screen. You can watch the picture but you are not able to make a further analysis.

### **Gallery**

Opens a [Gallery](#) so as you can watch taken pictures.

### **Calibration**

Opens a menu where you can choose one of two possible types of calibration.

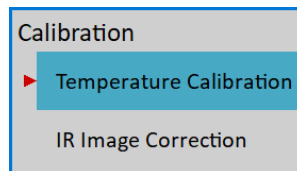

**Attention!** For both types of calibration, calibration constants are stored in the instrument and not in the camera itself. Thus, you need to perform the calibration procedure again when you connect another camera. Similarly, you need to perform the new calibration procedure when you connect the camera into another instrument.

### **Temperature Calibration**

Aging of camera electronics can cause inaccurate temperature measurement. For this case, you can use this IR camera calibration tool.

In the calibration process, you will be asked to make IR pictures of two objects with different temperature and entering their real temperatures into device. These two objects should be made from the same material with the same color and surface structure if possible. Another option is to cover the surface of the calibration objects with black adhesive tape. You have to know the real temperature of these objects for the calibration.

Take two captures (the **Capture** button changes into **Capture 1** and later into **Capture 2**) and enter the temperature value at the cursor position for each.

The calibration procedure automatically ends after entering the second temperature. New calibration constants are calculated and used. The procedure can be terminated by the **Escape** button. The **Reset Calibration** button erases the calibration constants from the instrument.

If you are not able to measure the real temperature of objects, there is a solution for you. Set the Emissivity to 0.96 and take an IR picture of boiling water surface and assign the temperature 100°C (212°F). As a second calibration picture, capture the surface of water from melting ice and assign the temperature 0°C (32°F).

### **IR Image Correction**

You may sometimes notice a corona effect or bad pixels on the IR image. The IR Camera Correction function should solve this problem.

ADASH

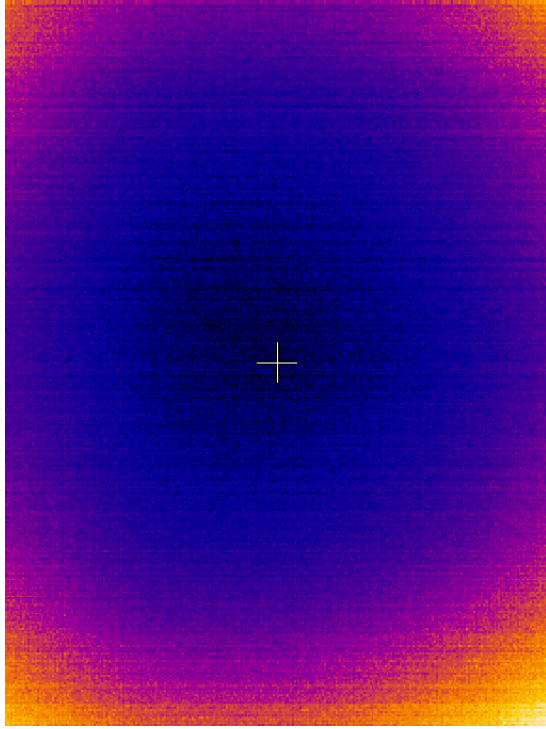

VA5 Pro

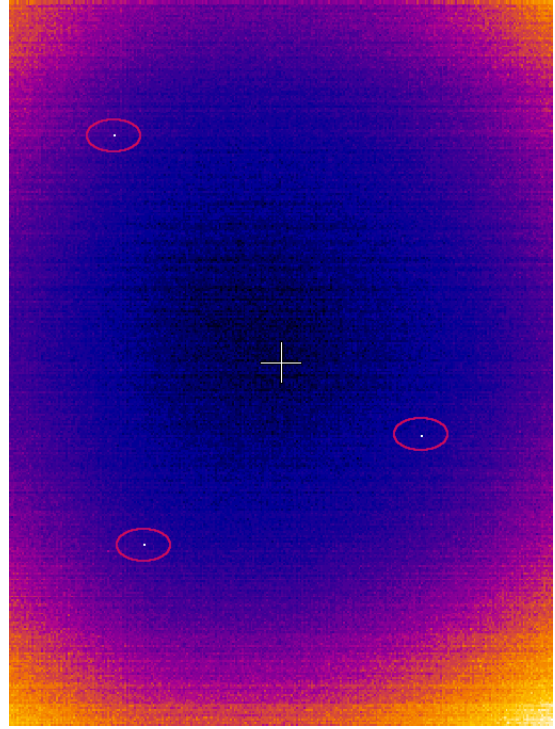

During this procedure, simply set the IR camera to see a uniform scene (e.g., the wall). Then press **Calibrate** and the image should be repaired. The uniform scene should then look like this:

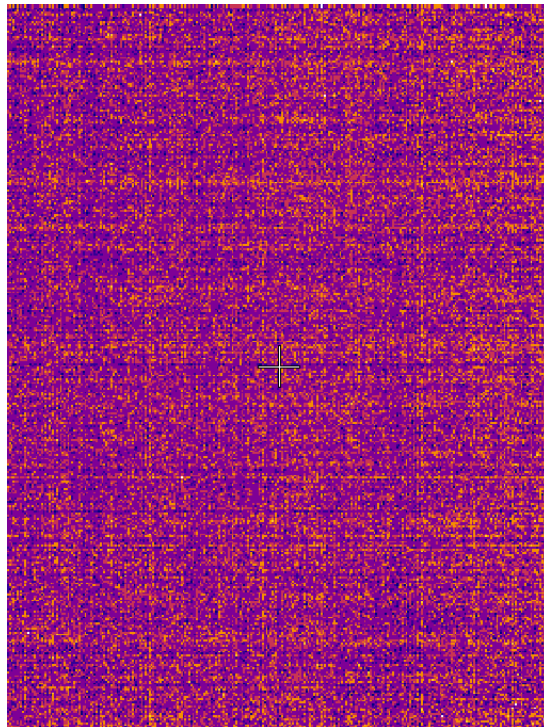

**Attention!** IR image distortion may be caused by insufficient warm-up of the IR camera. After connecting the IR camera, wait at least 5 minutes before running the IR Image Correction.

## **Graph Properties**

### **Unit**

Choose the temperature unit.

### **Emissivity**

The emissivity value of the observed place is needed to calculate the right temperature.

***Color spectrum***

Choose the colors of the images, **colored** or **black and white**.

***Scale***

**auto, user**

The **auto** scale ensures the highest possible contrast of the picture. With the **user** scale, you have a fixed color for each temperature.

# Gallery

The images from the camera, IR camera and also all screenshots ([MENU / RUN / Screenshot](#)) can be watched in the Gallery. You can watch the images as icons or one image on screen. Use the *Enter* button or double tap an image to maximize it. Then use the *Escape* button to restore the icons mode.

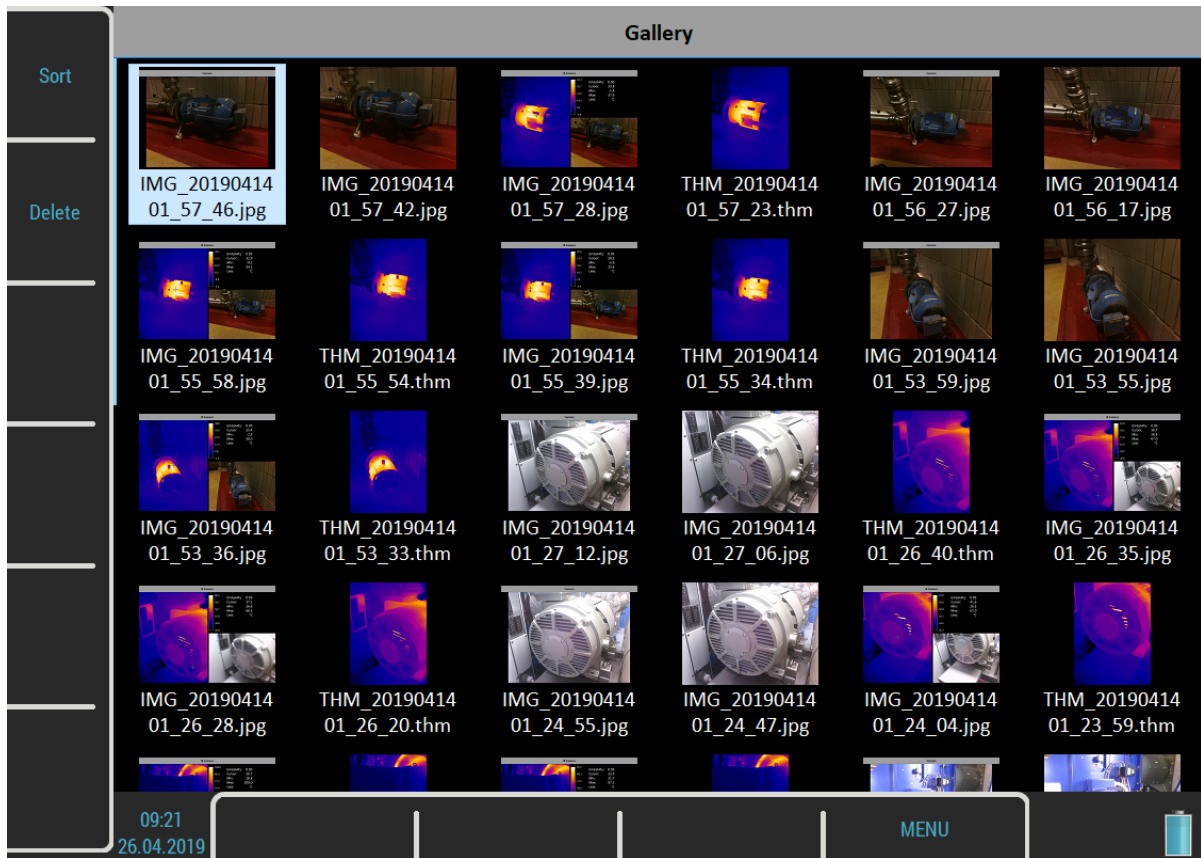

## Buttons

### Sort

You can sort the images by name or by time, in ascending or descending order.

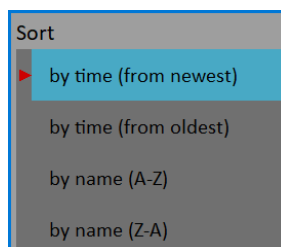

### Delete

Delete the selected image.



## Buttons for maximized IR Camera picture

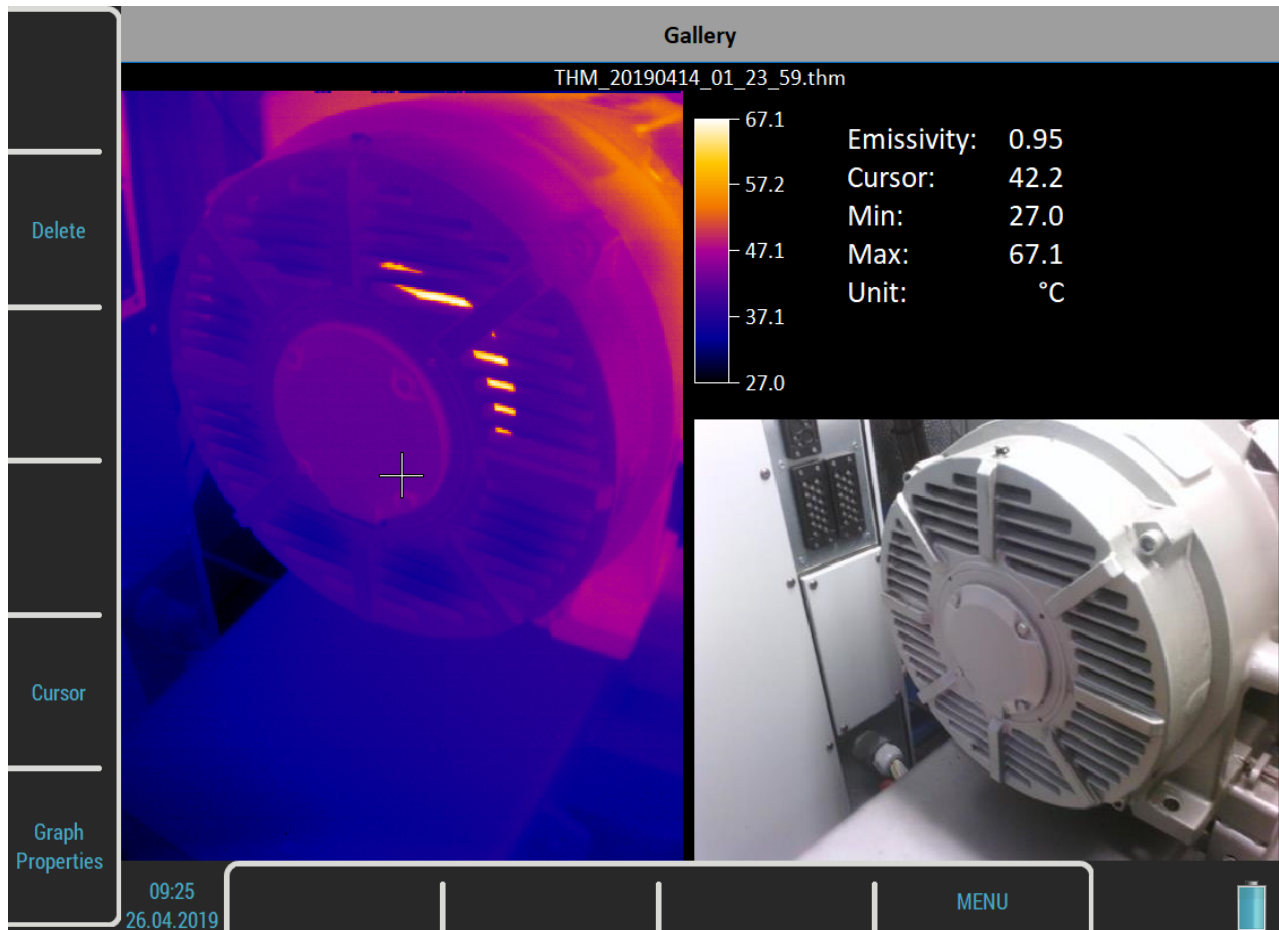

### Cursor

When a picture from [IR Camera](#) is maximized, you can also move the cursor. Push the **Cursor** button to switch arrows into the cursor mode. Then press the same button, now named **Gallery**, to return. You can also switch the mode by tapping the screen. Tap the IR camera picture to switch into the *Cursor* mode or tap outside the picture to switch into the *Gallery* mode.

### Graph Properties

Opens the [Graph Properties](#) menu like in the [IR Camera](#) module.

# **MCSA**

The MCSA (Motor Current Signature Analysis) module is used to determine induction motor faults by analyzing stator currents. You need three phases measurement for the whole analysis but most can be performed only with a single current measurement. Current clamps are used for the current measurements.

The module evaluates broken rotor bars or cracked rotor rings, shorted turns in stator windings, air-gap eccentricity, and power quality.

## **Sensors Settings**

The MCSA module is based on current measurements, therefore you need to define suitable current sensors. When you enter the module from main screen, predefined sensors will be automatically set. A "**Used Sensors**" message box informs you about it.

**Note!** The acceleration sensor on AC4 has no purpose for now. It may be used in the future.

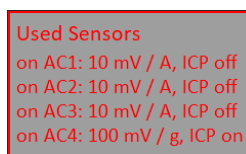

If you want to use different sensors you can setup them in the menu.

**Note!** The sensors menu is not available immediately after confirming the message box, because the [MCSA Settings](#) menu appears first.

**Note!** Once you have changed the sensors, your new setup will be saved and used as predefined sensors for the next time.

**Note!** Any sensors setup in the MCSA module applies just in this module. When you leave the module back to the main screen, the previous sensors will be restored to a state before entering the module. Therefore, if you want to make some further analysis in other modules you need to setup the sensors in the [Sensors](#) menu while not having opened the MCSA module.

## **MCSA Settings**

The *MCSA Settings* menu automatically appears after confirming used sensors. Enter a few parameters which are needed in the MCSA algorithm. This menu can also be opened later by pressing the *MCSA Settings* button.

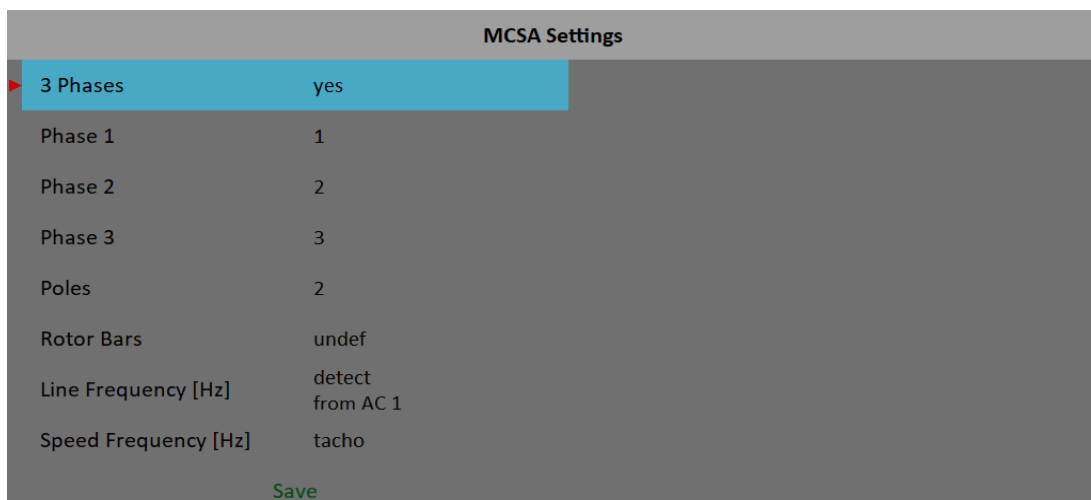

### **3 Phases**

**yes, no**

If you want to use all three phases to perform a complete MCSA analysis then select **yes**. One phase measurement doesn't enable you to check phase shifts and amplitude differences among phases. Thus, it doesn't enable you to evaluate stator faults.

### Phase 1 – 3

**1, 2, 3, 4**

Select channel number for each phase.

The "**Improper sensor**" note appears if there's currently no sensor defined on this channel.

|         |                      |
|---------|----------------------|
| Phase 1 | 1<br>Improper sensor |
|---------|----------------------|

### Poles

**2, 4, 6, 8, 10, 12, 14, 16, 18, 20, user**

Number of poles of analyzed motor. The number must be divisible by two.

### Rotor Bars

**undef, user**

Number of rotor bars of the analyzed motor

This catalog information may not always be available. If you leave this parameter undefined the measurement can normally continue but the eccentricity cannot be evaluated.

### Line Frequency

**detect, user**

Enter the value of the line (power grid) input frequency. If you don't know the value, then the **detect** choice can help you.

Signal for the detection is taken from *Phase 1* input channel. A note "**from AC 1**" informs you about it (the number in the note is always the same as *Phase 1* value).

|                     |                     |
|---------------------|---------------------|
| Line Frequency [Hz] | detect<br>from AC 1 |
|---------------------|---------------------|

The **Line Frequency Detection** is similar to [Speed detection](#) which is described in a stand alone chapter.

The "**Improper sensor**" note appears if there's currently no sensor defined on *Phase 1* channel.

|                     |                           |
|---------------------|---------------------------|
| Line Frequency [Hz] | detect<br>Improper sensor |
|---------------------|---------------------------|

The line frequency detection runs before MCSA measurement.

### Speed Frequency

**tacho, user**

Enter the value of speed frequency (rotor speed). If you don't know the value, then use a tacho probe.

Speed from the tacho probe is detected before MCSA measurement.

### Measurement

Push the *Enter* button to start the measurement. The line frequency and / or speed detection runs first if needed.

The duration of one reading can vary from about one second to a few tens of seconds. It depends on measured motor properties. A count down bar is displayed in status bar for longer measurements.

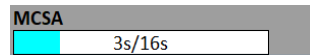

The measurement is automatically stopped when finished, or you can interrupt it by pushing the *Escape* button.

### MCSA Screen

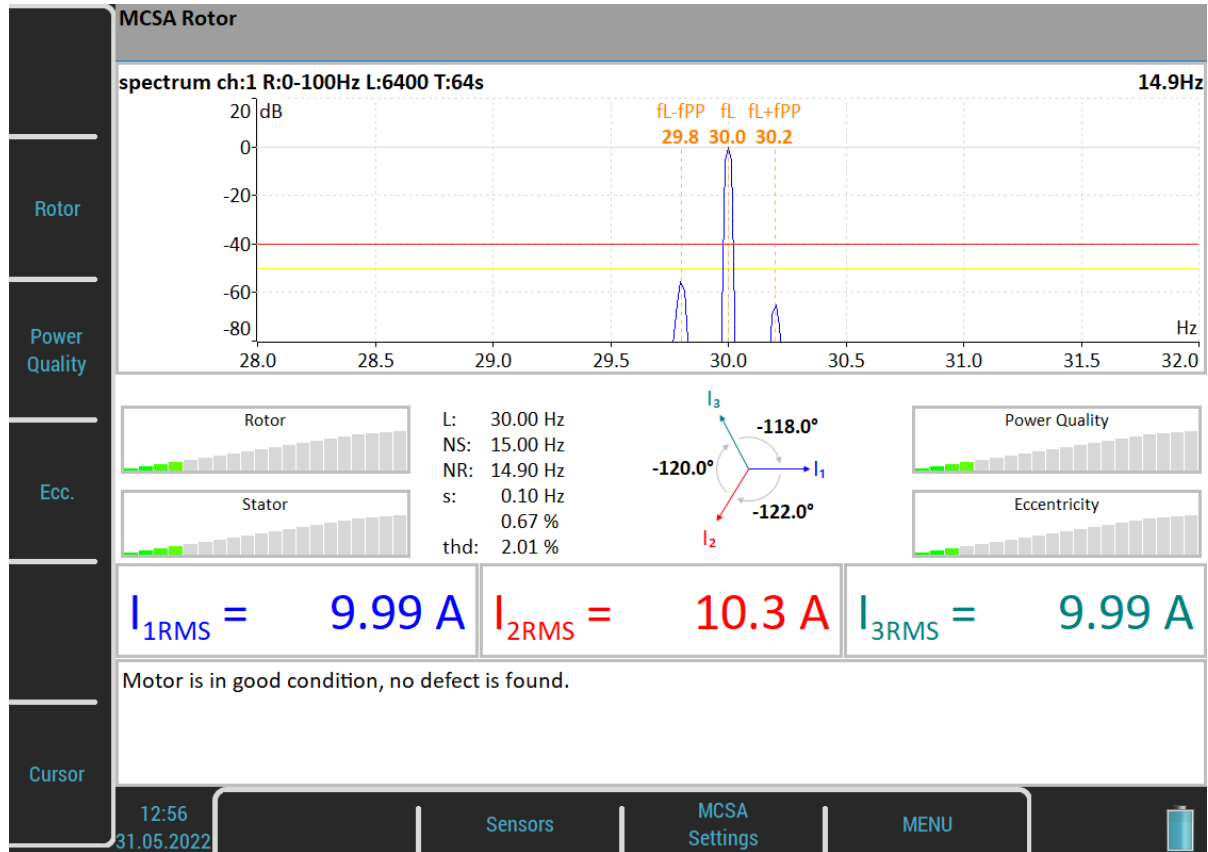

You can switch the displayed spectrum by pressing **Rotor**, **Power Quality** or the **Ecc.** button. The current choice is written to the status bar as "**MCSA Rotor**" and so on.

By pressing the **Cursor** button, you may turn a cursor in spectra on or off. You can use the cursor to explore the spectrum like in the analyzer module.

The **Sensors** button opens the [Sensors](#) menu. This is the default shortcut which can be changed.

The **MCSA Settings** button opens the MCSA menu.

The **MENU** button opens the main global menu.

The screen contains several indicators. Let's discuss them.

#### Rotor spectrum

It's displayed by default. Push the **Rotor** button to display it again when another spectrum had been chosen.

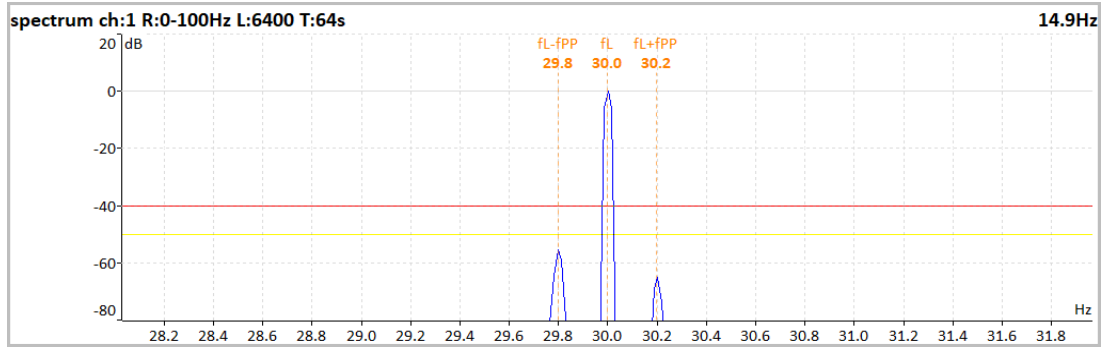

It is a frequency spectrum around line frequency. The spectrum is displayed in dB with line frequency as a reference value.

Three frequencies are marked:

$fL$  means line frequency.

$fL +/- fPP$  means pole pass sideband around the line frequency.

Two limits are marked:

- -50 dB for warning
- -40 dB for danger

There is a simple rule. If the difference between the main and the sideband components is greater than 50dB, a rotor has no faults. When the difference ranges between 40 and 50 dB there is probably one bar broken. With the difference greater than 50 dB, there are several broken bars or a broken end ring (as mentioned in **Brief Review of Motor Current Signature Analysis** statement by Dubravko Miljković, Croatia).

### Power quality spectrum

Push the **Power Quality** button to display it.

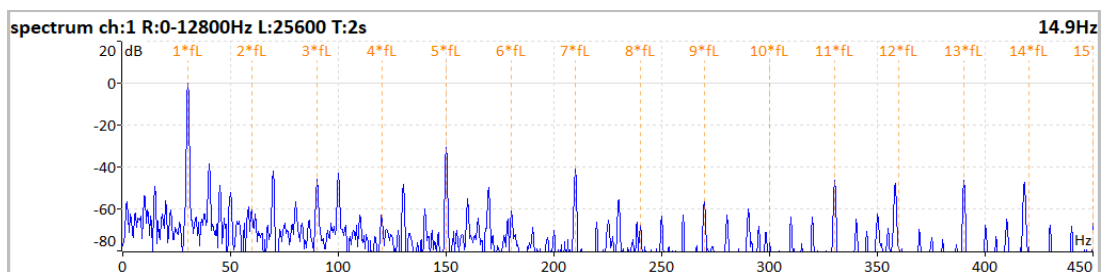

Line frequency harmonics are marked in this spectrum.

### Eccentricity spectrum

Push the **Ecc.** button to display it.

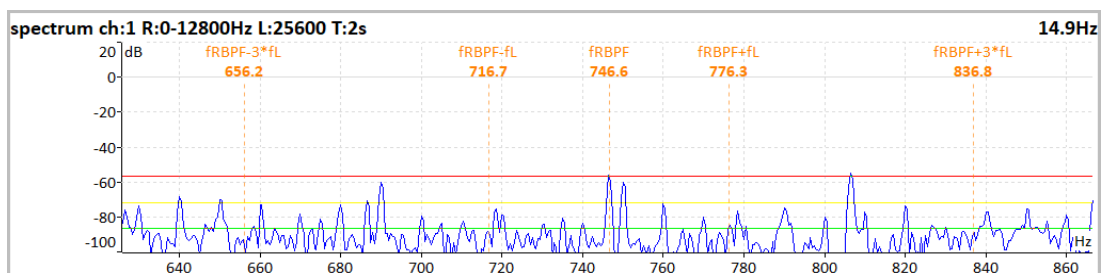

Eccentricity characteristic frequencies are marked in this spectrum. That means the **rotor bar pass frequency (f<sub>RBPF</sub>)** and its odd sidebands (**f<sub>RBPF</sub> +/- f<sub>L</sub>** and **f<sub>RBPF</sub> +/- 3f<sub>L</sub>**). Limits for eccentricity detection are also marked.

f<sub>RBPF</sub> = speed frequency \* number of rotor bars

### Severity bars

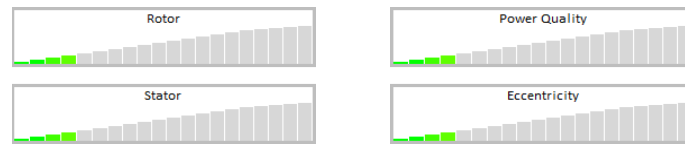

Each horizontal bar displays the severity of the individual item. It starts from green color on the left to the red on the right.

Rotor severity is detected from the values on pole pass sidebands.

Stator severity is detected from the difference between 3 current values.

Power Quality is detected from total harmonic distortion of the current signal.

Eccentricity is detected from values on Eccentricity characteristic frequencies.

### Phasor diagram

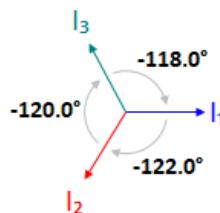

You can check phase shifts among phases. Furthermore, direction of arrows in the phasor diagram corresponds to the direction of rotation of a motor, whether it is clockwise or counter clockwise.

### Frequency table and thd

L: 30.00 Hz  
 NS: 15.00 Hz  
 NR: 14.90 Hz  
 s: 0.10 Hz  
 0.67 %  
 thd: 2.01 %

- **L** line frequency
- **NS** synchronous speed
- **NR** rotor speed
- **s** slip
- **thd** total harmonic distortion of power supply signal

### Current values

|                             |                             |                             |
|-----------------------------|-----------------------------|-----------------------------|
| $I_{1RMS} = 9.99 \text{ A}$ | $I_{2RMS} = 10.3 \text{ A}$ | $I_{3RMS} = 9.99 \text{ A}$ |
|-----------------------------|-----------------------------|-----------------------------|

Current RMS values of all phases are displayed.

## Information window

Motor is in good condition, no defect is found.

All detected faults are summarized here in text form. The displayed message describes severity bars states and brings some additional information.

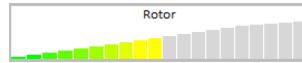

Attention! There is probably a resistance change in the rotor winding. Rotor bars or rings could be broken.

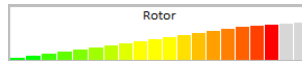

Danger! Rotor bars are broken.

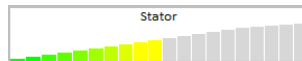

Attention! A stator winding probably has a current imbalance. This fault could be caused by a change of winding resistance.

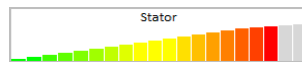

Danger! There are probably shorted turns in the stator winding. Another short circuit is possible.

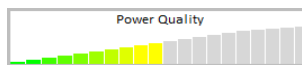

Attention! Phase currents include harmonics. They are probably caused by drive influencing or electromagnetic asymmetry in motor.

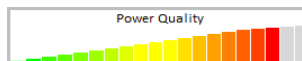

Danger! Phase currents include harmonics. They are probably caused by drive influencing or electromagnetic asymmetry in motor.

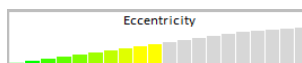

Attention! A motor air gap could be variable. It is caused by eccentric rotor.

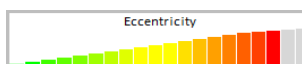

Danger! A motor air gap is variable. It is caused by eccentric rotor.

## Errors and warnings

### Unstable line frequency or speed

MCSA analysis may be influenced by unstable line frequency or speed. If one of these values varies, you'll be informed by a notification text above right severity bar.



In addition, a message box appears after the measurement completes.



### High speed

When the speed is too close to the synchronous speed, that means slip approaches zero and the “**High Speed**” error is thrown. In this case, rotor faults cannot be detected.

### One phase measurement



In case you use one phase measurement, some indicators are not available. The stator severity is not defined. Of course, phasor diagram and current values are missing.



## **A4404 – SAB and Virtual Unit**

**Virtual Unit** is the same software as the one used in **VA5** vibration analyzer. You can use the Virtual Unit in demo mode and see the VA5 instrument working environment. In other words, you can download and install the Virtual Unit free of charge and see all the measurement capabilities of the instrument.

You can also use the Virtual Unit to post process your records from a real instrument.

Furthermore, the Virtual Unit is designed for measurement with the **A4404 – SAB**.

### **Installation**

#### **A4404 – SAB Drivers Installation**

Connect the SAB to a computer via USB cable which is a part of SAB accessories. The drivers should be installed automatically from the internet. In case you have no internet connection or some problem occurs, follow these instructions:

1. Download a driver file from <https://adash.com/downloads/third-parties-software> or from the supplied SAB installation flash drive.
2. Uncompress the file anywhere on your computer (for example, C:\A4404).
3. Connect the A4404 – SAB to your PC via USB cable.
4. The “*Add Hardware Wizard*” window should open when drivers are not found on your PC. Follow the wizard instructions.
5. Select “*Install from a list or specific location*” and click the *Next* button.
6. Check “*Include this location in the search*”.
7. Click the *Browse* button and select the folder where you uncompressed the driver.
8. Click the *Next* button and wait for the installation to complete.
9. You may delete the downloaded file and folder with the uncompressed driver (not required).

#### **Virtual Unit Installation**

Download Virtual Unit from the Adash website <http://www.adash.com/downloads/adash-software> or from SAB installation flash drive. Run the file and follow the installation wizard instructions. You’ll be asked to enter the installation destination path (the default value is *C:\Program Files (x86)\Adash\Virtual Unit*) and the path for working folder where all data of the application will be stored (the default value is *C:\ProgramData\Virtual Unit*). In this folder, two subfolders will be created after the first run, **data** and **VA5\_DISC**. The data folder is equivalent to the instrument’s internal disk and the **VA5\_DISC** folder is equivalent to the instrument’s flash drive (see [General Information](#) / [Connection to the computer](#)).

**Note!** You don’t need to export routes nor other projects to the **VA5\_DISC** in the Virtual Unit. DDS can find them directly in the data folder.

#### **License file**

Each A4404 – SAB device is supplied with a unique license file. The Virtual Unit needs the license file **adashx123456.a44** in order to control the A4404 – SAB (the 123456 is the serial number of A4404). Copy this file from the supplied flash drive into the working folder **data\VA4licence** folder.

### **Update**

To update the software, just run the installation file with the newer version. The old version will be replaced. The application data will not be lost.

### **Operation**

If you want to use the A4404 – SAB, plug it before you launch the Virtual Unit application. The computer with the connected SAB and running Virtual Unit then behaves like a VA5 instrument.

Live signal is measured only with the A4404 – SAB. It's possible to post process records without this device. Virtual Unit installation contains one record (*Default Rec*) for demonstration. You can download more Records here: <http://adash.com/download/Records.zip>. You can also post process your own records from the instrument.

## VA5 Virtual unit and VA5 Pro connection

How to share projects between the instrument and the Virtual Unit will be described in this chapter. Connect the instrument to a computer via USB cable. The instrument will be found as the *VA5\_DISC* (removable disk) on your system. It's possible to copy the data between Virtual Unit's working folder and the instrument's *VA5\_DISC*.

### Copying projects into the instrument

Copy the *data\VA4analyser\ProjectName* project folder from Virtual Unit's working folder into the *VA4analyser* folder on the instrument's *VA5\_DISC*. Attention! The *VA5\_DISC* is the real removable storage device here, NOT the Virtual Unit's folder! You have to create an **empty file** with the name ***script.dds*** in the project folder on the instrument's *VA5\_DISC*. This ensures importing of the project into the instrument's internal disk after entering the Analyzer module. The same file is created by DDS. Runup (*VA4runup* folder), Route (*VA4route* folder), and Octave Analysis (*VA4octave* folder) projects are copied the same way.

Example:

You've got a route called *Power Station* in Virtual Unit and you want to have it in a real instrument as well.

1. Connect the instrument with the computer via USB cable. The instrument must be turned off or on the main screen.
2. A new USB drive called *VA5\_DISC* appears among the computer's disks.
3. Open the *VA4route* folder on *VA5\_DISC*.
4. Open the *data\Va4route* folder in the Virtual Unit's working folder. Find the *Power Station* folder in this folder.
5. Copy the *Power Station* folder to the *VA4route* folder on the *VA5\_DISC*.
6. Create an empty file named ***script.dds*** in *VA4route\Power Station* on *VA5\_DISC*.
7. Enter the Route module in the instrument.
8. The *Power station* route will be automatically imported and shown in the project list.

### Projects and records copy from the instrument

**Attention!** Projects have to be exported to the *VA5\_DISC* first, just like an export for DDS.

Copy the *VA4analyser\ProjectName* folder from the instrument's *VA5\_DISC* folder into the Virtual Unit's working folder. In this case, you don't need to create the *script.dds* file as in copying into an instrument. Runup (*VA4runup* folder), Route (*VA4route* folder), Octave Analysis (*VA4octave* folder), Balancer (*VA4balancer* folder), and Recorder (*VA4recorder* folder) are copied the same way.

Example:

You've got a route called *Power Station* in the instrument and you want to have it in Virtual Unit as well.

1. Open the *data\Va4route* folder in the Virtual Unit's working folder.
2. Open the Route module in the instrument.
3. Select the *Power Station* route.
4. Export the route to the *VA5\_DISC* using the *Route / Export* menu item.
5. Connect the instrument with the computer via USB cable.
6. New USB drive called *VA5\_DISC* appears among the computer's disks.
7. Open the *VA4route* folder on the *VA5\_DISC*. Find the *Power Station* folder in this folder.
8. Copy the *Power Station* folder from the *data\Va4route* folder in the Virtual Unit's working folder.
9. Open the Route module in the Virtual Unit. The *Power Station* route is in the list with other routes.

## **Appendix A: Technical Specification**

### **Inputs**

#### **Dynamic Channels (AC)**

|   |   |
|---|---|
| Number of synchronous parallel channels (AC): | 4 AC  |
| Frequency range (-3dB):                       | 0.35 - max 90000 Hz<br>(196 kHz sampling frequency)   |
| Input range:                                  | +/- 12V (only one range, no gains)  |
| Measurement timing:                           | fully synchronous   |
| A/D Resolution:                               | 24 bit input, 64 bit double floating point internal precision<br>(no gain procedures used!) |
| Dynamic range:                                | 120 dB  |
| Channel configuration:                        | voltage or ICP (individually for every channel)   |
| Input protection:                             | up to 30 V  |
| Input impedance:                              | 100 kOhm  |
| Input type:                                   | acceleration, velocity, displacement, any non-vibration AC voltage                          |
| Integration:                                  | single, double fully digital integration  |
| 2D Processing:                                | axis rotation according to sensor mounting  |
| Accuracy:                                     | < 0.5 %   |
| ICP drive:                                    | 18 V, 3.8 mA  |
| User HP filtering:                            | 0.35Hz - 12800 Hz   |
| User LP filtering:                            | 25Hz - 90000 Hz   |
| Connector:                                    | ODU   |

#### **Tacho / External Channel**

|                   |   |
|-------------------|---|
| Number:           | 1 independent tacho input   |
| Speed range:      | 0.01Hz - 1000 Hz  |
| Input impedance:  | 80 kOhm   |
| Input type:       | voltage   |
| Input range:      | + 10V (only one range, no gains)<br>or +/-30V (tacho / external signal + DC) with optional tacho signal converter |
| Accuracy:         | <0.5 %  |
| Trigger level:    | 0.1 -9.9 V, user defined  |
| Input protection: | up to 48 V  |
| Connector:        | ODU   |

#### **Static Channels (DC or 4-20mA)**

|                   |   |
|-------------------|---|
| Number:           | 4 DC or 4-20mA (has to be specified in order) |
| Input range:      | +/- 24 V or 4-20mA                            |
| Input impedance:  | 100kOhm (V-DC), 250 Ohm (4-20mA-DC)           |
| A/D Resolution:   | 12 bit input                                  |
| Accuracy:         | 0.1% fsd                                      |
| Input protection: | up to 30 V                                    |

### **Measurement Functions**

|                      |  |
|----------------------|--|
| Data Analysis Speed: | 0.1 sec for 25600 lines FFT spectrum               |
| Amplitude Units:     | Metric, Imperial (English), or user programmable   |
| Frequency Units:     | Hz, CPS, RPM, CPM, Orders                          |
| Amplitude scale:     | Acceleration, Velocity, Displacement, User defined |
| Scaling:             | Linear or Log, both X and Y axes                   |
| Cursor:              | Single, Harmonics, Sidebands                       |
| Triggering:          | free run<br>tacho                                  |

|   |  |
|---|--|
| ADASH   | VA5 Pro  |
|   | amplitude (positive or negative)                                   |
|   | external (voltage)   |
| Signal Range:   | full, No Auto ranging  |
| Data acquisition:   | TRUE RMS, TRUE PEAK, TRUE PEAK-PEAK, overall, or band values       |
|   | user defined high, low, and band pass filters for band measurement |
|   | time waveforms (8 388 608 samples max)                             |
|   | real-time FFT  |
|   | 3D graphs (waterfall, cascade)                                     |
|   | order analysis   |
|   | Amplitude + phase values on speed frequency                        |
|   | speed measurement  |
|   | process static DC or 4-20mA values                                 |
|   | Envelope demodulation  |
|   | ACMT procedure for low-speed machines bearings                     |
| Time waveform samples:                                    | 256 – 8 388 608  |
| Waveform (ACMT) length:                                   | max 131 072 sec (36 hours)   |
| Spectrum ranges:  | 25 – 90 000 Hz   |
| Spectrum lines:   | 100 – 3 276 800  |
| Spectrum peaks listing:                                   | yes  |
| Spectrum units:   | RMS, 0-P and P-P   |
| Windows:  | Rectangular, Hanning, Exponential, Transient, Flat top             |
| Order analysis parameters:                                | 1/2 - 10th order   |
| Averaging:  | 1-255  |
| Overlap:  | yes  |
| Smax, Gap, and Centerline displays for proximity sensors: | yes  |

### **Recording:**

|                        |  |
|------------------------|--|
| Sampling frequency:    | user defined in the range 64Hz - 196 kHz   |
| Record length example: | 3 GB for 1 hour record with 64kHz sampling (4ch AC+4ch DC+1ch tachometer / external signal)                            |
|                        | (100GB memory enables over 30 hours of full 64kHz recording, a lower sampling frequency enables a much longer record)) |

### **Balancing:**

|   |                     |
|---|---------------------|
| Planes:   | 1 or 2              |
| Speed range:  | 0,5 Hz - 1000 Hz    |
| Balancing Advisor for automatic fault detection:        | yes                 |
| Balancing Quality factor according to ISO21940:         | yes                 |
| Balancing vector graph for balancing process reporting: | yes                 |
| Balancing Report:                                       | yes                 |
| Trim function:  | yes                 |
| Vector split (for example, to blades positions):        | yes                 |
| Manual entry:   | yes                 |
| Intuitive graphic user interface:                       | yes                 |
| Trial mass:   | get out or leave in |

### **Camera:**

|             |                        |
|-------------|------------------------|
| Resolution: | 5 mpix, 2592 x 1944 px |
| Focus:      | auto                   |

### **IR camera:**

|                    |                               |
|--------------------|-------------------------------|
| Resolution:        | 384 x 288 px                  |
| Temperature Range: | -10°C ~ 250°C (-10°C ~ 150°C) |
| Lens:              | 6.8mm F 1.3                   |
| NETD:              | < 50mK                        |

ADASH

VA5 Pro

**General:**

|                                      |  |
|--------------------------------------|--|
| Processor:                           | Atom 1.9 GHz   |
| RAM:                                 | 2 GB   |
| Display:                             | LCD color 191 x 134 mm (9.1" diagonal), 1140x800 resolution      |
| Memory (Internal SSD):               | 64 GB  |
| Memory (VA5_DISC flash):             | 16 GB  |
| Interface:                           | USB  |
| Powering:                            | Li-Ion long life battery pack (more than 8 hours of measurement) |
| Operating temperature:               | -10 °C - +50 °C, 15°F-120°F                                      |
| EMC:                                 | CE tested  |
| Dimensions:                          | 280 x 205 x 55 mm  |
| Weight:                              | 2.2 kg   |
| Electromagnetic Compatibility (EMC): | ČSN EN IEC 61326-1:2022  |

## Appendix B : Phase measurement conventions

### **Single channel measurement with tachometer**

Let's assume a time signal defined as  $y = \cos(\omega t)$ . We use the cosine function because FFT uses it too. It simplifies the calculations and understanding.

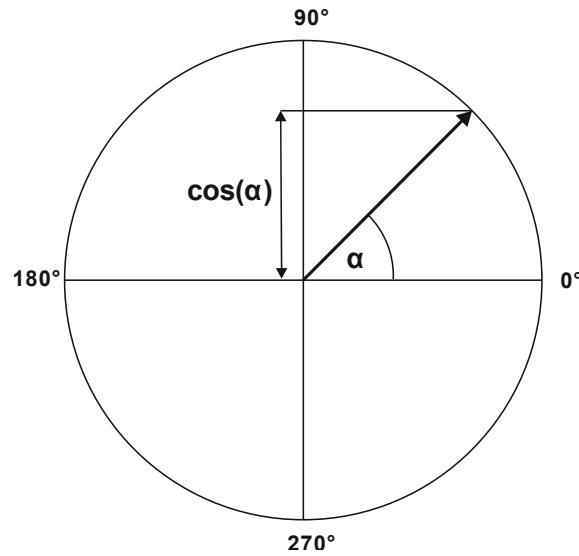

Our starting position of a rotating vector  $V$  will be  $90^\circ$ . We will mark it as  $T_0$ .

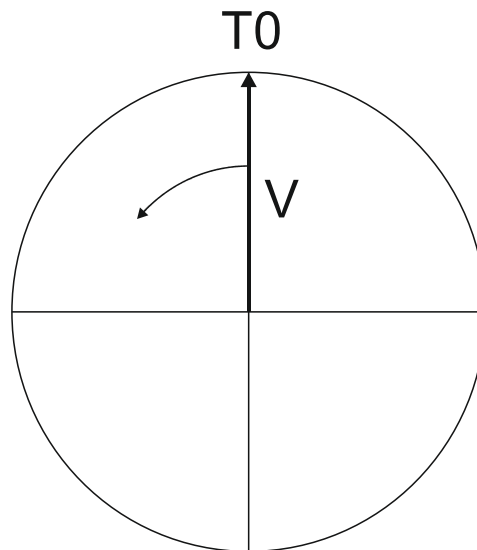

When the vector  $V$  rotates, for example, 3 times, then we get the time signal as follows.

ADASH

VA5 Pro

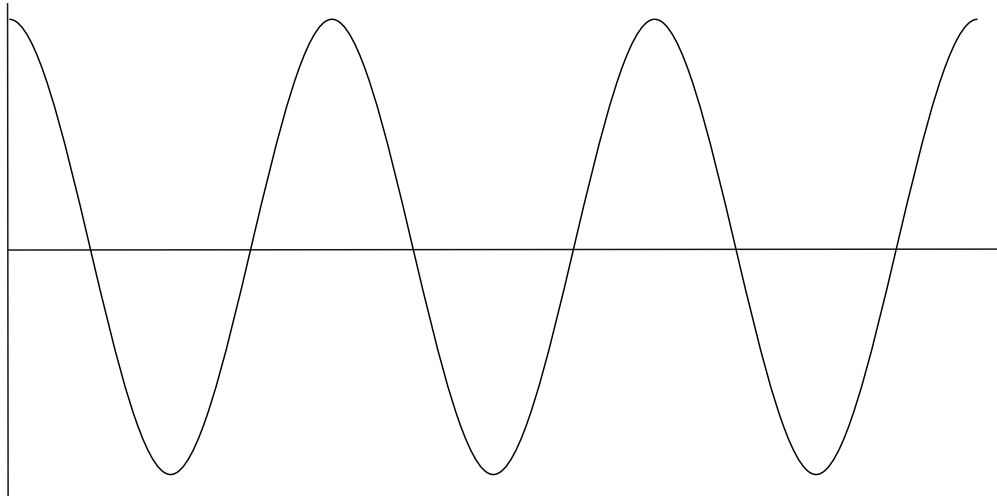

Now we assume the tacho signal. We put the tacho pulse to the T0 position.

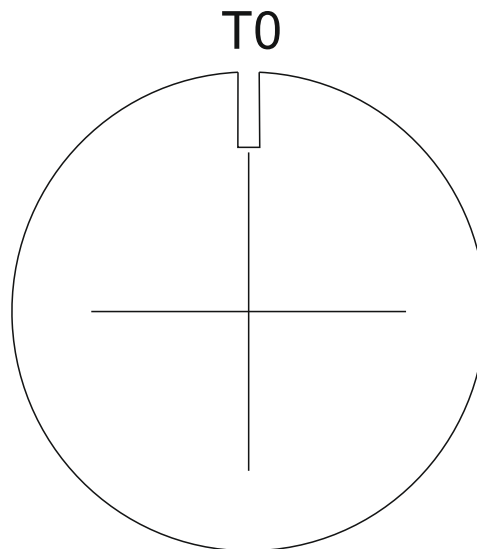

The corresponding time signal with tacho pulses is on the following picture.

Now, we begin to assume the phase shift (marked as  $\varphi$ ) of the time signal vs. the tacho signal. The signal formula changes to  $y = \cos(\omega t + \varphi)$ . The previous picture corresponds to  $\varphi = 0^\circ$ , and this value is displayed on the instrument screen. When the tacho pulses are in the maximum time signal positions, then the phase value is equal to zero.

Now, assume the  $\varphi = 45^\circ$ . We use the degrees unit to make it simple for all readers. Radians have to be used for an exact math formula.

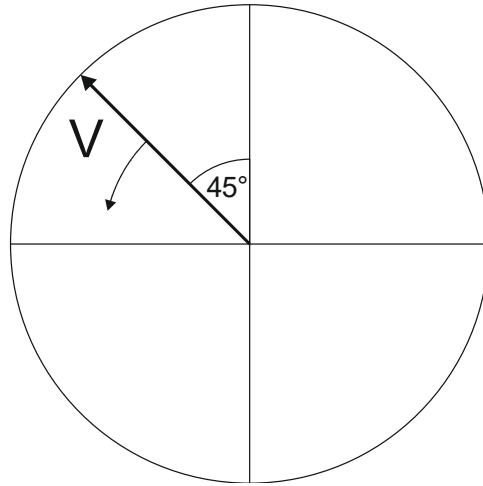

The corresponding time signal with tacho pulses is in the next picture.

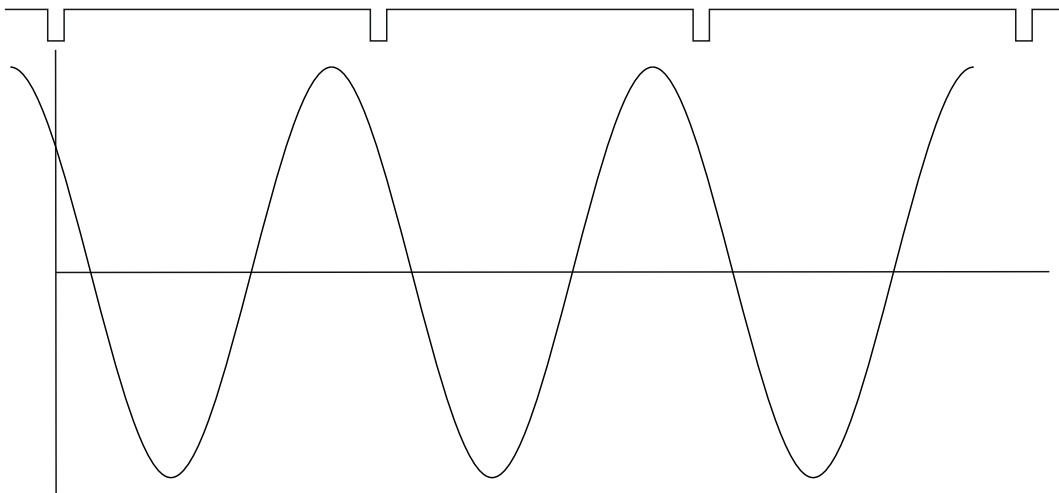

The time signal gets ahead of the tacho signal by 45°. A 45° value appears on the instrument screen in this case.

Now we assume the  $\varphi = -45^\circ$ .

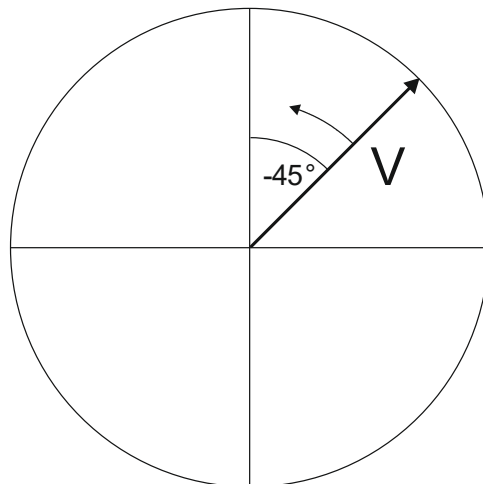

The corresponding time signal is in the next picture.



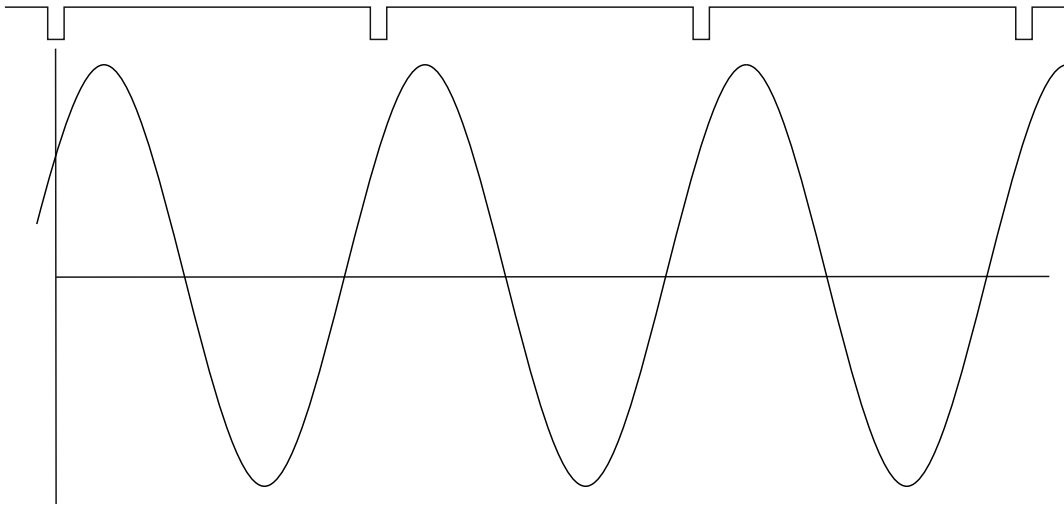

The time signal is delayed. A  $-45^\circ$  value appears on the instrument screen in this case.

This approach is used for single channel measurement as amp+phase and orders.

### ***Dual channel measurement***

We must always define the channels of A and B. For example, we use channel 1 as A and channel 2 as B. You always have to assign the channel numbers of A and B. The A represents the input channel and B the output channel. You can imagine it as a black box and you need to measure the phase response of that.

For example, you can see this on the display:

$\Phi_B - \Phi_A: +59.9^\circ$

The logic is the same as for a single channel measurement. The A has the same function as a tacho signal. This  $60^\circ$  means that B is ahead of the A by  $60^\circ$ .

This approach is used for double channel measurements as phase shift and frf.

### ***Last reminder***

We talk about time signals and their positions in time in this chapter. We have used words such as “the signal is ahead” and on the other side that “the signal is delayed”.

You should always keep in mind:

**To be ahead of, for example, by  $60^\circ$  is the same as to be delayed by  $300^\circ$ . Don't forget that we are working with periodic pure cosine time waveform.**

## **Appendix C: Symbols and Abbreviations**

### **Inputs**

|           |   |
|-----------|---|
| AC1 – AC4 | alternating current signal, channel 1 – 4 |
| DC1 – DC4 | direct current signal, channel 1 – 4      |

### **Abbreviations in Graphs**

|                         |  |
|-------------------------|--|
| ch                      | channel, input   |
| NS                      | number of samples  |
| R                       | number of revolutions  |
| L                       | number of lines  |
| B                       | frequency band   |
| R                       | frequency range  |
| FS, fs                  | sampling frequency   |
| Y                       | y value on cursor's position   |
| t                       | cursor position on the time axis                                     |
| f                       | cursor position on the frequency axis                                |
| df                      | frequency resolution (delta)   |
| A                       | A value on the cursor's position (orbit, center line)                |
| B                       | B value on the cursor's position (orbit, center line)                |
| A                       | amplitude value on the cursor's position (spectrum, frf)             |
| P                       | phase value on the cursor's position                                 |
| Coh                     | coherence value on the cursor's position                             |
| Re                      | real value on the cursor's position                                  |
| Im                      | imag value on the cursor's position                                  |
| X                       | value calculated from signals A and B to axis X (orbit, center line) |
| Y                       | value calculated from signals A and B to axis Y (orbit, center line) |
| S                       | speed value  |
| D                       | difference value   |
| d                       | delta cursor length  |
| b                       | value of the band bounded by delta cursor in spectrum                |
| tot                     | value of the whole band in spectrum                                  |
| RMS, 0P                 | rms and 0P value in the time signal bounded by delta cursor          |
| totRMS, tot0P           | rms and 0P value in the whole time signal                            |
| HYPERLINK \l "_toc2720" |  |